

**EATON**

**Aeroquip**

**Marine/Military Catalog**



**Aeroquip®**

# Indexes

## Mil-Spec Reference

Eaton Corporation supplies products that meet many Military and Federal Specifications. The extent of this capability is indicated in the following listing.

We have purposely omitted revision letters so that this list does not become outdated and restrictive in nature.

The Marine and Military Group with prime responsibility for the specified product is the best and quickest source of information. The address is as follows:

Eaton  
14615 Lone Oak Road  
Eden Prairie, MN  
55344-2287  
(952) 937-7190 or  
(952) 937-7263  
Fax: (952) 937-7394  
www.hydraulics.eaton.com

SPECIFICATION	DESCRIPTION	AEROQUIP HOSE PART NUMBER
<b>MIL-DTL-3992</b> TYPE I CLASS 1	Airbrake Hose	2554-6
<b>MIL-DTL-8794</b>	Medium Pressure, Wire Braid Hose	303, 302A
<b>MIL-DTL-13444</b> TYPE I TYPE III	Hose, Rubber, Fuel and Oil	2565 FC173
<b>MIL-DTL-13531</b> TYPE I CLASS A TYPE II CLASS A	Hose, Rubber Hydraulic	2665 2766
<b>MIL-H-24135</b> MIL-H-24135/1 MIL-H-24135/2 MIL-H-24135/4 MIL-H-24135/5 MIL-H-24135/9 MIL-H-24135/10 MIL-H-24135/12 MIL-H-24135/13	Hose, Rubber, Wire Reinforced	FC163 FC162 150901 AE371 AE374 AE369, AE370-40, -48 AE372 AE373
<b>MIL-H-24136</b> MIL-H-24136/1 MIL-H-24136/3 MIL-H-24136/4	Hose, Rubber, Fiber Reinforced	2580-80 through -192 2580-4 through -32 FC132
<b>MIL-F-24787</b> MIL-F-24787/1 MIL-F-24787/2 MIL-F-24787/3 MIL-F-24787/4 MIL-F-24787/5 MIL-F-24787/6 MIL-F-24787/7	Fittings, End Reusable for MIL-H-24135 and MIL-H-24136 Flange, Class I, II, III, IV, V 37° Flare O-Ring Seal Union (CPV) Split Clamps with Tail Pieces 90° Elbow Hose to Hose (Dogleg) 180° Elbow Return Hose to Hose Gasket Seal Union (not for new construction) (Walseal)	
<b>MIL-DTL-52471</b> TYPE 100R2	Hose, Rubber, Hydraulic	FC163
<b>MIL-DTL-52525</b>	Fittings for MIL-DTL-13531 and MIL-DTL-52471	
<b>MIL-H-24595</b>	Hose, Rubber, Wire Reinforced	2758

# Indexes

## Section Index

<b>SECTION</b>	<b>PAGES</b>	
Master index	<b>3-6</b>	This catalog has been designed to include current and complete product information on the Aeroquip Hose and Fittings most suited to naval and marine product applications.
"FH" Computer Part Number Conversion Chart	<b>7</b>	
Hose	<b>8-23</b>	Information is indexed by part number, by product type, and by application on board ship.
Fittings	<b>24-141</b>	Detailed data is included on materials, material specifications, component part numbers, and Military Specifications.
Adapters	<b>142-144</b>	
Accessories Assembly Instructions And Assembly Equipment	<b>145-173</b>	
Technical Data	<b>174-205</b>	

# Introduction

## Master Part Number Index

<b>SECTION</b>	<b>PAGES</b>	<b>PART NUMBER</b>	<b>PAGE</b>	<b>PART NUMBER</b>	<b>PAGE</b>	<b>PART NUMBER</b>	<b>PAGE</b>
Master Index	3-6	AE369	14	FC7031-206	41	FJ7358-S	30
"FH" Competitor Part Number Conversion Chart	7	AE370	17	FC7750-188	108	FJ8343-4	86
Hose	8-23	AE371	18	FC7751-188	110	FJ8368-4	85
Fittings	24-141	AE372	13	FC7752-188	112	FJ8525-4	138
Adapters	142-144	AE373	16	FC7753-188	113	FJ8548-4	132
Accessories Assembly Instructions And Assembly equipment	145-173	AE374	17	FC7754-188	114	FJ9068-S	26
Technical Data	174-205	FC132	19	FC7754-410	115	FJ9343-41	86
		FC162	16	FC7755-188	111	FJ9364-41	83
		FC163	15	FC7780-188	110	FJ9366-41	84
		FC173	12	FC7781-188	108	FJ9368-41	85
		FC234	14	FC7781-410	109	FJ9369-41	87
		FC363	21	FC7862-228	140	FJ9401-253	135
		FC364	21	FC8223-4	74	FJ9486-B	26
		FC425	147	FC8224-176	74	FJ9525-253	138
		FC1198-S	83-87	FC9056-463	73	FJ9548-253	132
		FC1198-1-S	83-87	FC9073-375	101	FJ9706-S	43
		FC1266-4	135	FC9074-375	103	FJ9707-S	43
		FC2457-188	108-115	FC9171	131	FJ9708-S	44
		FC2457-1-188	108-115	FC9224-463	74	FJ9709-S	44
		FC2463-188	108	FC9341	131	FT1013	155
		FC2463-407	109	FC9423-375	66	FT1028	156
		FC2464-188	110	FC9424-375	66	FT1033	156
		FC2465-188	112	FC9425-375	67	FT1101	153, 154
		FC2466-188	113	FC9426-375	67	FT1211A	157
		FC2467-188	114	FC9506-463	73	FT1212	159
		FC2467-410	115	FC9527-188	116	FT1215	153, 154
		FC2468-188	111	FC9528-188	122	FT1220	157
		FC2552-C	140	FC9568-188	118	FT1222	159
		FC2925-10	129	FC9583-375	100	FT1229	157, 158
		FC3056-4	73	FC9589-375	102	FT1230	157, 158
		FC3476-188	116-122	FC9635-188	120	FT1234	156
		FC3477-188	116-122	FC9636-188	121	FT1260	153
		FC3478-188	116, 118	FC9637-188	117	FT1261	160
		FC3479-188	122	FC9638-188	119	FT1281	155
		FC3555-188	120	FF5001-188	66-67, 101, 103, 123	FT1312	160
		FC3557-188	121	FF5002-188	66-67, 100, 102, 123	S1026	153, 154
		FC3558-188	119	FF9003	123	S1043	154
		FC4307-4	139	FF9033	108-115	S1102	154
		FC5307-253	139	FF9142	116-122	S1104	153
		FC5707-108	129	FF9217	147	S1118	153, 154
		FC5847-S	28	FF9411	108-115	S1120	154
		FC5848-S	28	FF9412	108-115	SC1681	154
		FC5849-S	28	FF9700-262	148	SC1709	153, 154
		FC5852-S	29	FH9515	7, 125	SC1772	153
		FC5853-S	26	FJ7023-S	30	07.001	32
		FC5954-S	47	FJ7044-S	29	07.002	47

# Introduction

## Master Part Number Index

<b>PART NUMBER</b>	<b>PAGE</b>	<b>PART NUMBER</b>	<b>PAGE</b>	<b>PART NUMBER</b>	<b>PAGE</b>	<b>PART NUMBER</b>	<b>PAGE</b>
07.003	46	1598	157	4797-B	27	190000-S	36
07.006	32	1599	157	14-21002	125	66-190016	59
07.021	31	1605	158	4-21004	88-104	66-190093	54
07.024	45	1606	158	4-21023	88-104	375-190093	55
07.025	31	4-2223	87	21027-S	83-87	412-190093	54
07.026	46	2556	11	21028-S	83-87	66-190103	64,65
07.036	47	2565	11	22006	123-124, 126	66-190109	57
07.114	32	2580 -4 thru -32	15	22015	49-53, 126	375-190109	58
07.122	30	2580 -80 thru -192	19	22020	123-124, 126	412-190109	58
07.155	48	2665	13	22550	49-53, 126	190111-S	41
07.340	44	2758	20	188-72019	123	66-190124	60-61
07.390	30	2766	18	188-72039	123	375-190124	63
07.421	45	2807	22	188-72462	123	412-190124	62
302A	12	2808	22	188-72463	123	473-190210	107
303	12	4-4010	68-74	4-73458	87	473-190215	105
401-S	34	4-4013	68-78	4-73461	71	473-190216	106
403-S	41	4-4103	69, 75	74021	140	190235-S	42
406-B	34	4-4103-4	69, 75	188-74021	57-63, 89, 95, 108, 110	120260-S	38
4-411	33	188-4112	89, 91-93, 105	407-74021	58, 62, 90, 96, 109	190261-S	38
412-S	35	407-4112	90, 94	407-74031	94	190265-S	37
44-412	35	4-4202	68	188-74045	73-74, 92, 98, 105, 108, 110, 116	38-190268	136
473A-C	128	4401-S	34	188-74048	93, 99, 118, 119	190276-S	41
624	147	4402-S	36	150901	20	190277-S	41
4-1205	88-104	4-4202	68	188-180005	59, 64, 65, 91, 97	190295-S	38
1206	127-129	4411-S	34	407-185029	62	190296-S	38
1208	133-140	4412-S	35	188-185093	54-55	190297-S	37
1210-B	50, 53, 56	4414-S	37	407-185093	54	190299-S	37
4-1210	33, 49, 51-52, 55	4706-S	79	188-185109	57-59	190301-S	38
1212-B	49-67	4-4721	69	407-185109	58	190302-S	38
4-1212	33, 49-67	4-4722	68	188-185203	104, 107	190325-S	42
474-1218	105-107	4729-S	79	188-185204	104	190327-S	29
188-1237	66	4730-S	79	188-185212	106	190328-S	29
188-1239	101, 106	4-4730	75	188-185215	105	190350-S	42
4-1251	33	4738-B	26	188-185249	67	190371-S	42
1266	128	4739-B	27	474-1218-1	107	473-190388	105
1267	127	4740-B	27	188-185029	60, 61, 63-65	473-190390	106
4-1290	33	4741-B	27	63-185535	137	190463-S	36
1526	155	4742-B	27	185535-C	134	190465-S	29
1561-S	157	4743-B	28	4-186301	52-53	190468-S	80
1562	157	4750-B	28	4-186302	55-56	190469-S	80
1563-S	157	4753-B	26	4-186304	71, 77	190470-S	80
1582-S	157	4772-B	28	4-186305	72, 78	190516-S	29
1583	158	4775-S	39	4-186314	86	190528-S	79
1583-1	158	4776-S	39	4-186324	87	190535-C	134
583-S	157-158	4777-S	40	4-186348	83	63-190535	137
1597	157	4779-S	40			190600-C	128

# Introduction

## Master Part Number Index

<b>PART NUMBER</b>	<b>PAGE</b>	<b>PART NUMBER</b>	<b>PAGE</b>
63-190600	130	4-210005	107
190627-C	127	4-210200	107
38-190627	130	220572-C	133
190628-C	133	4-220643	70
375-190655	91	4-220657	84
375-190656	97	188-220779	49-50
190672-B	27	4-220779	49-50
375-190717	88	408-220779	51
375-190751	92	222019S	158
375-190752	93	222022	146
375-190757	98	4-222048	116-122
375-190758	99	4-222075	87
375-190767	89	2580-4 thru -32	15
412-190767	90	2580 -80 thru -192	19
375-190769	95	472003-S	81
190772	131	474403-S	80
190773	131	474503-S	81
375-190781	101	476003-S	81
375-190784	102	476703-S	82
375-190785	103	479001-S	82
375-190786	104	479003-S	82
190846-S	39	188-500063	123
4-190885	76	188-500189	123
4-190909	70	900515	133-140
66-190911	50	900564	146
4-190911	49	900568	127-132
375-190911	49	900705	146
93-190911	50	900729	148
411-190911	51	115-900757	125
190944-S	29	900758	125
63-190990	130	900762	125
190997-S	81	900952	146
4-191301	52	4-921641	52-53
93-191301	53	191321-S	29
4-191302	55	412-190814	94
93-191302	56	413-190769	96
4-191304	71	375-190780	100
4-191307	77	222005	146
4-191308	78	4-191305	72
191321-S	29	220554-B	137
191395-S	40	220572-B	136
4-202140	143		
4-202142	143		
446-202232	144		
4-202240	144		
4-202242	144		

# Introduction

## “FH” Computer Part Number Conversion To Aeroquip Part Number

### Example of Old Part No.

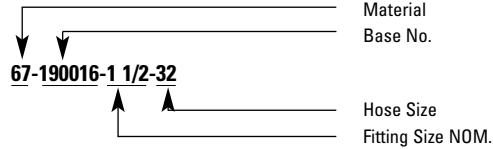

### Example of New Part No.

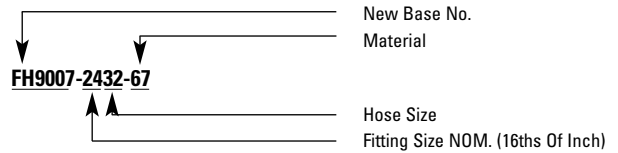

OLD AEROQUIP PART NO.	NEW AEROQUIP PART NO.	OLD AEROQUIP PART NO.	NEW AEROQUIP PART NO.	OLD AEROQUIP PART NO.	NEW AEROQUIP PART NO.	OLD AEROQUIP PART NO.	NEW AEROQUIP PART NO.
1239	FH9525	190769	FH9035	185229	FH9532	190388	FH9020
2020	FH9552	190780	FH9036	185249	FH9533	190390	FH9073
2084	FH9555	190781	FH9037	185391	FH9001	190467	FH9078
4112	FH9517	190783	FH9038	185660	FH9002	190490	FH9021
72020	FH9549	190784	FH9039	185713	FH9003	190642	FH9022
72042	FH9500	190785	FH9040	185887	FH9058	190655	FH9023
72465	FH9543	190786	FH9041	185908	FH9062	190656	FH9024
73461	FH9526	190814	FH9083	186301	FH9059	190660	FH9025
73472	FH9536	190887	FH9042	186303	FH9004	190713	FH9026
74021	FH9527	190908	FH9043	186304	FH9060	203002	FH9514
74031	FH9558	190909	FH9044	186312	FH9005	203002	FH9061
74048	FH9540	190911	FH9045	186313	FH9027	203003	FH9546
74414	FH9550	190912	FH9046	190014	FH9066	203004	FH9545
40204	FH9000	191301	FH9047	190016	FH9007	203005	FH9547
124204	FH9518	191303	FH9048	190103	FH9008	203009	FH9548
180005	FH9501	191304	FH9049	190109	FH9009	203102	FH9553
185014	FH9519	191305	FH9085	190124	FH9010	210000	FH9515
185029	FH9502	191312	FH9050	190162	FH9075	210203	FH9516
185109	FH9528	191313	FH9051	190163	FH9011	220625	FH9534
185174	FH9529	191315	FH9052	190164	FH9012	220643	FH9520
185203	FH9503	191316	FH9053	190173	FH9066	220657	FH9521
185204	FH9504	191443	FH9054	190174	FH9067	220779	FH9522
185205	FH9530	191444	FH9077	190183	FH9074	221501	FH9557
185212	FH9505	202103	FH9508	190205	FH9071	420302	FH9523
185219	FH9506	202113	FH9551	190210	FH9013	420306	FH9524
185221	FH9531	202142	FH9538	190212	FH9014	500083	FH9079
185226	FH9507	202204	FH9509	190216	FH9015	500165	FH9063
190717	FH9072	202222	FH9057	190219	FH9016	504046	FH9064
190751	FH9028	202222	FH9510	190225	FH9068	900841	FH9055
190752	FH9029	202223	FH9511	190232	FH9070		
190753	FH9030	202232	FH9567	190233	FH9080		
190754	FH9031	202237	FH9512	190234	FH9017		
190757	FH9032	202242	FH9537	190237	FH9018		
190758	FH9033	202701	FH9569	190248	FH9056		
190764	FH9082	202702	FH9513	190252	FH9069		
190767	FH9034	185226	FH9507	190286	FH9019		

# Hose

## Hose Part Number Index

<b>SECTION</b>	<b>PAGES</b>
<b>Master Index</b>	<b>3-6</b>
<b>"FH" Competitor Part Number Conversion Chart</b>	<b>7</b>
<b>Hose</b>	<b>8-23</b>
<b>Fittings</b>	<b>24-141</b>
<b>Adapters</b>	<b>142-144</b>
<b>Accessories Assembly Instructions And Assembly equipment</b>	<b>145-173</b>
<b>Technical Data</b>	<b>174-205</b>

<b>HOSE AND ACCESSORIES</b>	<b>PAGE</b>
<b>LOW PRESSURE</b>	
2565	11
2556	11
<b>MEDIUM PRESSURE</b>	
303/302A	12
FC163	15
FC173	12
2665	13
AE372	13
FC234	14
AE369	14
2580 -4 thru -32	15
<b>HIGH PRESSURE</b>	
AE373	16
FC162	16
AE374	17
AE370	17
AE371	18
2766	18
<b>LARGE BORE</b>	
FC132	19
2580 -80 thru -192	19
150901	20
2758	20
<b>PTFE (Teflon*)</b>	
FC363	21
FC364	21
2807	22
2808	22
<b>Special</b>	
678 (Hose Assemblies)	23

\*Teflon is a DuPont trademark



# Hose

## How To Order

### How to order

Accurate processing and prompt delivery of your order depends on easy identification of your requirements. Please order Eaton Aeroquip parts using correct part numbers as described in this catalog. Inquiries and orders should be directed to your Eaton Aeroquip Distributor or:

Eaton  
14615 Lone Oak Road  
Eden Prairie, MN  
55344-2287  
(952) 937-7190 or  
(952) 937-7262  
Fax: (952) 937-7394  
[www.hydraulics.eaton.com](http://www.hydraulics.eaton.com)

### Part numbers and dash sizes

Dash size designates the nominal size in 16ths of an inch. This number immediately follows the part number and is separated from it with a dash.

### Dimensions

Dimensions given in this catalog for Eaton Aeroquip products are approximate and should be used for reference only. Exact dimensional information for a given product is subject to change and varying tolerances; contact Eaton directly for full current information.

### Hose assemblies

Eaton manufactures the terminal ends of our hose fittings to the appropriate requirements established by the SAE. Therefore, the performance ratings of these hose fittings meet the SAE/MIL SPEC requirements. It is possible to order a hose assembly with a fitting terminal end that has a performance rating lower than the hose rating. When ordering hose assemblies, please keep the connecting end performance rating in mind since this may affect overall hose assembly performance.

Hose assembly components (hose and fittings) are easily assembled in the field. However, factory assembled reusable and crimped hose assemblies are available. For complete information, contact Eaton.

### Cut length hose

Cut lengths of hose should be ordered as shown below by specifying lengths in inches.

For numeric part numbers: AE369-10-00484

Hose type \_\_\_\_\_

Hose size (in 16ths of an inch) \_\_\_\_\_

Cut length (in inches) \_\_\_\_\_

last digit is in 1/16ths of an inch 00484 = 48 1/2 inches

For alpha-numeric part numbers: FC163-08-00484

Hose type \_\_\_\_\_

Hose dash size \_\_\_\_\_

Cut length (in inches) \_\_\_\_\_

Last digit is in 1/16ths of an inch 00484 = 48 1/2 inches

### Bulk hose

Bulk hose should be ordered by specifying length in feet as shown below.

Complete numbers: 150 ft.-AE372-10

Quantity (in feet) \_\_\_\_\_

Hose type \_\_\_\_\_

Hose size (in 16ths of an inch) \_\_\_\_\_

Note: Length tolerance for hose, assemblies and sleeves is:

Up to and including 12 inches:  $\pm 1/8"$

Above 12 inches to and including 18 inches:  $\pm 3/16"$

Above 18 inches to and including 36 inches:  $\pm 1/4"$

Above 36 inches:  $\pm 1%$  of length

# Hose

## Hose Pressure By Size

### Hose dash size to maximum operating pressure

This table is intended as a guide in the selection of hose by maximum operating pressure.

It is not a guarantee.

Final selection is further dependent on fluid and ambient temperature, concentration of agent, intermittent or continuous exposure, etc.

PART NUMBER	PAGE	HOSE DASH SIZE																		
		-3	-4	-5	-6	-8	-10	-12	-16	-20	-24	-32	-40	-48	-64	-80	-96	-128	-160	-192
2556	11		360		300	300	250	250												
2565	11		300		250	200	175	125												
2758	20															500	350			
AE370	17												350	200/450*						
302A	12							800	600	500	350									
FC132	19												1000	900	600					
2580	15, 19		1000	800	650	625	600	550	500	450	400	350				300	300	300	200	150
150901	20												1200	900	600					
FC363	21					1250		1100	1000	1000	750	500								
FC364	21					1250		1100	1000	1000	750	500	100							
FC173	12				1000	1000	875	750	375											
FC234	14			1500	1500	1250	1250	750	400											
2665	13		2750		2250	2000	1500	1250	1000											
2808	22				2750	2500	1750	1500	1125	800										
2807	22	3000	3000	3000	2500	2000	1500	1200	1000	625										
AE372	13		3000	3000	2250	2000	1750	1500	800	625	500	300	300							
AE369	14		3000	3000	2250	2000	1750	1500	800	625	500	350	350							
303	12		3000	3000	2000	2000	1750	1500												
2766	18		5000		4000	3500		2250	2000	1625	1250	1000								
FC163	15				4000	3500	2750	2250	2000	1625	1250	1125								
AE371	18		5000		4000	3500	2750	2250	2000	1625	1250	1125								
AE373	16		5750		5000	4250	3250	3000	2500	2250	1750	1500								
AE374	17					7500		6250	5000	4000	3000	3000								
FC162	16				4500	4000		3000	3000											

\* Applicable only when using segmented type marine fittings.

# Hose

## 2556

### Low Pressure SOCKETLESS™



PART NUMBER	HOSE I.D.	HOSE O.D.	MAXIMUM OPERATING PRESSURE	MINIMUM BURST PRESSURE	MINIMUM BEND RADIUS	VACUUM SERVICE	WEIGHT PER FOOT
	INCHES	INCHES	PSI	PSI	INCHES	INCH/Hg	POUNDS
#							
2556-4	.27	.50	360	1440	3.00	28	.08
2556-6	.38	.62	300	1200	3.00	28	.14
2556-8	.50	.75	300	1200	5.00	28	.17
2556-10	.63	.91	250	1000	6.00	18	.22
2556-12	.75	1.03	250	1000	7.00	18	.26

FITTING REFERENCE	PAGE
Pipe	26
SAE 37°	27-29
Steel	26-32
SAE 45°	27-29
Universal	27-29
Compression Type	28
Accessories see page Assembly	149-152
Instructions see page	165

**Construction:** Synthetic rubber tube, textile braid reinforcement, synthetic rubber cover.

**Application:** For gasoline, crude, fuel and lubricating oils, air and water. Does not provide a fire-resistant product per USCG requirements: Table 56, 60-25 (c), USCG 115 Title 46, however, it does have a self-extinguishing cover. For more specific information on fluid applications, see page 176.

**Operating Temperature Range:** -40°F to +180°F (-40°C to 82°C). Air not to exceed +160°F (71°C). Water not to exceed +150°F (+66°C).

## 2565

### Low Pressure SOCKETLESS™ Meets MIL-DTL-13444 Type 1, Class A, Hose and SAE 30R2 Type 1.1



PART NUMBER	HOSE I.D.	HOSE O.D.	MAXIMUM OPERATING PRESSURE	MINIMUM BURST PRESSURE	MINIMUM BEND RADIUS	VACUUM SERVICE	WEIGHT PER FOOT
	INCHES	INCHES	PSI	PSI	INCHES	INCH/Hg	POUNDS
#							
2565-4	.25	.50	300	1250	2.25	20	.09
2565-6	.38	.63	250	1000	3.00	20	.12
2565-8	.50	.78	200	750	3.75	10	.17
2565-10	.63	.97	175	700	4.75	10	.28
2565-12	.75	1.09	125	500	5.50	10	.30

FITTING REFERENCE	PAGE
Pipe	26
SAE 37°	27-29
Steel	26-32
SAE 45°	27-29
Universal	27-29
Compression Type	28
Accessories see page Assembly	149-152
Instructions see page	165

**Construction:** Synthetic rubber inner tube, textile braid reinforcement and synthetic rubber cover.

**Application:** Gasoline, crude, fuel and lubricating oils, air and water. For more specific information on fluid application, see page 176.

**Operating Temperature Range:** -65°F to +250°F (-54°C to +121°C). Air not to exceed +160°F (+71°C) maximum. Water not to exceed +150°F (+66°C).

# Hose

## 303, 302A

Medium Pressure  
Meets MIL-DTL-8794



PART NUMBER	HOSE I.D.	HOSE O.D.	MAXIMUM OPERATING PRESSURE	MINIMUM BURST PRESSURE	MINIMUM BEND RADIUS	VACUUM SERVICE	WEIGHT PER FOOT
	INCHES	INCHES	PSI	PSI	INCHES	INCH/Hg	POUNDS
#							
303-4	.19	.52	3000	12000	3.00	28	.13
303-5	.25	.58	3000	10000	3.38	28	.16
303-6	.31	.68	2000	9000	4.00	28	.23
303-8	.41	.77	2000	8000	4.62	28	.26
303-10	.50	.92	1750	7000	5.50	28	.37
303-12	.62	1.08	1500	6000	6.50	28	.46
302A16	.88	1.23	800	3200	7.38	28	.44
302A20	1.12	1.50	600	2500	9.00	28	.52
302A24	1.38	1.75	500	2000	11.00	28	.67
302A32	1.81	2.22	350	1400	13.25	28	.94

FITTING REFERENCE	PAGE
SAE 37"	33
CPV	49-53
Dogleg	54-56
Flange	57-65
Split Clamp	66-67
Steel	34-48
Accessories see page Assembly	149-152
Instructions see page	166

**Construction:** Synthetic rubber tube, cotton inner braid, single wire braid reinforcement and synthetic rubber impregnated textile braid cover.  
**Application:** For hydraulics, air, gasoline, fuel and lubricating oils.  
 For more specific information on fluid applications, see page 176.  
**Operating Temperature Range:** 303: -65°F to +250°F (-54°C to +121°C).  
 302A: -40°F to +250°F (-40°C to +121°C).

## FC173

Medium Pressure  
Meets MIL-DTL-13444  
Type III



PART NUMBER	HOSE I.D.	HOSE O.D.	MAXIMUM OPERATING PRESSURE	MINIMUM BURST PRESSURE	MINIMUM BEND RADIUS	VACUUM SERVICE	WEIGHT PER FOOT
	INCHES	INCHES	PSI	PSI	INCHES	INCH/Hg	POUNDS
#							
FC173-06	.31	.62	1000	4000	1.25		.15
FC173-08	.41	.74	1000	4000	1.75		.18
FC173-10	.50	.83	875	3500	2.25		.23
FC173-12	.63	.96	750	3000	2.75		.25
FC173-16	.88	1.21	375	1500	3.50		.32

**FITTING REFERENCE**  
 For fittings contact Eaton

**Construction:** Oil resistant inner tube, textile braid, single wire braid and synthetic rubber impregnated textile braided cover.  
**Application:** Diesel fuel, gasoline, hot lube oil, water & air.  
**Operating Temperature Range:** -55°F to +300°F (-49°C to +150°C).

# Hose

## 2665

High Pressure  
Meets MIL-DTL-13531  
Type 1, Class A



PART NUMBER	HOSE I.D.	HOSE O.D.	MAXIMUM OPERATING PRESSURE	MINIMUM BURST PRESSURE	MINIMUM BEND RADIUS	VACUUM SERVICE	WEIGHT PER FOOT
	INCHES	INCHES	PSI	PSI	INCHES	INCH/Hg	POUNDS
#							
2665-4	.25	.63	2750	11000	4.00		.19
2665-6	.38	.78	2250	9000	5.00		.30
2665-8	.50	.91	2000	8000	7.00		.39
2665-10	.63	1.03	1500	6000	8.50		.46
2665-12	.75	1.19	1250	5000	9.50		.53
2665-16	1.00	1.50	1000	4000	11.00		.80

**FITTING REFERENCE**      **PAGE**  
**Crimp Fittings Available**  
**Contact Eaton**  
**Accessories see page**      **149-152**

**Construction:** Synthetic rubber tube, single steel wire braid reinforcement, and ozone and fungus resistant neoprene outer cover.  
**Application:** Hydraulics, fuel, lubricating oils, and gasoline and water.  
 For more specific information on fluid compatibility, **see page 176.**  
**Operating Temperature Range:** -65°F to +250°F (-54°C to +121°C).

## AE372

Medium Pressure  
ABS Approved Hose  
Meets MIL-H-24135/12  
Non-Mil-Spec  
Part Number FC300



PART NUMBER	HOSE I.D.	HOSE O.D.	MAXIMUM OPERATING PRESSURE	MINIMUM BURST PRESSURE	MINIMUM BEND RADIUS	VACUUM SERVICE	WEIGHT PER FOOT
	INCHES	INCHES	PSI	PSI	INCHES	INCH/Hg	POUNDS
#							
AE372-4	.19	.52	3000	12000	3.00	28	.15
AE372-5	.25	.58	3000	12000	3.38	28	.19
AE372-6	.31	.68	2250	9000	4.00	28	.23
AE372-8	.41	.77	2000	8000	4.62	28	.28
AE372-10	.50	.92	1750	7000	5.50	28	.39
AE372-12	.62	1.08	1500	6000	6.50	28	.47
AE372-16	.88	1.23	800	3200	7.38	†20†	.41
AE372-20	1.12	1.50	625	2500	9.00	†20†	.59
AE372-24	1.38	1.75	500	2000	10.50	†15†	.72
AE372-32	1.81	2.23	‡300‡	‡1200‡	13.25	†11†	.90
AE372-40	2.38	2.88	300	1200	24.00	† 8†	1.63

**FITTING REFERENCE**      **PAGE**  
 SAE 37°      **33**  
 CPV      **49-53**  
 Dogleg      **54-56**  
 Flange      **57-65**  
 Split Clamp      **66-67**  
 Steel      **34-48**  
**Crimp Fittings Available**  
**Contact Eaton**  
**Accessories see page**      **149-152**  
**Assembly**  
**Instructions see page**      **166**

**Construction:** AQP elastomer tube, polyester inner braid, single wire braid reinforcement and polyester braid cover. Blue for identification.  
**Application:** Hydraulics handling petroleum based fluids, air, gasoline, fuel and lubricating oil and other industrial fluids. Exceeds SAE100R5 and J1019 and is NAVSEA approved for shipboard applications per 9505, OPR: 56Y231, Ser: 56Y23/650. For more specification information on fluid applications, **see page 176.**  
**Operating Temperature Range:** Suitable for many applications between -55°F. and +300°F (-49°C to +150°C). Air not to exceed +250°F (+121°C).  
 †Maximum negative pressures shown for -16 and larger are suitable only for hose which has suffered no external damage or kinking. If greater negative pressures are required for -16 and larger hoses, the use of an internal support coil is recommended.  
 ‡Does not comply with SAE100R5 operating pressure of 350 psi or Minimum burst of 1400 psi.

# Hose

## FC234

Medium Pressure  
 ABS Approved.  
 Meets Fire Resistant  
 per USCG, SAE J1942.  
 Meets Marine FuelHose  
 per SAE J1527 Type A1



PART NUMBER	HOSE I.D.	HOSE O.D.	MAXIMUM OPERATING PRESSURE	MINIMUM BURST PRESSURE	MINIMUM BEND RADIUS	VACUUM SERVICE	WEIGHT PER FOOT
	INCHES	INCHES	PSI	PSI	INCHES	INCH/Hg	POUNDS
FC234-05	.25	.58	1500	6000	1.00	28	.22
FC234-06	.31	.68	1500	6000	1.25	28	.25
FC234-08	.41	.76	1250	5000	1.75	28	.30
FC234-10	.50	.94	1250	5000	2.25	28	.45
FC234-12	.63	1.08	750	3000	2.75	20	.48
FC234-16	.88	1.24	400	1600	3.50	16	.51

FITTING REFERENCE	PAGE
SAE 37°	33
CPV	49-53
Dogleg	54-56
Flange	57-65
Split Clamp	66-67
Steel	34-38
Accessories see page Assembly	149-152
Instructions see page	166

**Construction:** AQP elastomer tube, brass plated steel wire reinforcement, braided refractory insulation and blue AQP elastomer cover.  
**Application:** Hydraulic, crude, fuel and lubricating oils, gasoline, water and phosphate-ester based hydraulic fluids. For more specific information on fluid compatibility, see page 176.  
**Operating Temperature Range:** -40°F to +300°F (-40°C to +150°C).

## AE369

Medium Pressure  
 ABS Approved.  
 Meets  
 MIL-H-24135/10  
 Non-Mil Spec  
 Part Number 2651



PART NUMBER	HOSE I.D.	HOSE O.D.	MAXIMUM OPERATING PRESSURE	MINIMUM BURST PRESSURE	MINIMUM BEND RADIUS	VACUUM SERVICE	WEIGHT PER FOOT
	INCHES	INCHES	PSI	PSI	INCHES	INCH/Hg	POUNDS
AE369-4	.19	.52	3000	12000	3.00	28	.17
AE369-5	.25	.58	3000	12000	3.38	28	.18
AE369-6	.31	.67	2250	9000	4.00	28	.24
AE369-8	.41	.77	2000	8000	4.62	28	.27
AE369-10	.50	.92	1750	7000	5.50	28	.38
AE369-12	.62	1.08	1500	6000	6.50	28	.47
AE369-16	.88	1.23	800	3200	7.38	20†	.45
AE369-20	1.12	1.50	625	2500	9.00	20†	.57
AE369-24	1.38	1.75	500	2000	10.50	15†	.67
AE369-32	1.81	2.22	350	1400	13.25	11†	.94
AE369-40	2.38	2.88	350	1400	24.00	11†	1.43

FITTING REFERENCE	PAGE
SAE 37°	33
CPV	49-53
Dogleg	54-56
Flange	57-65
Split Clamp	66-67
Steel	34-38
Accessories see page Assembly	149-152
Instructions see page	166

**Construction:** Synthetic rubber tube, textile inner braid, single steel wire braid, textile outer braid, synthetic rubber cover.  
**Application:** Hydraulics, fuel and lube oils, fresh and salt water, low pressure air, nitrogen and butane. Approved per Technical Directive for Piping Devices – Flexible Hose Assemblies, S6430-AE-TED-010, Volume 1. For more specific information on fluid compatibility, see page 176.  
**Operating Temperature Range:** -40°F to +212°F (-40°C to +100°C).  
 \*Internal support coil required.  
 †Maximum negative pressures shown for -16 and larger are suitable only for hose which has suffered no external damage or kinking. If greater negative pressures are required for -16 and larger hoses, the use of an internal support coil is recommended.

# Hose

## 2580

Medium Pressure  
Meets MIL-H-24136/3



PART NUMBER	HOSE I.D.	HOSE O.D.	MAXIMUM OPERATING PRESSURE	MINIMUM BURST PRESSURE	MINIMUM BEND RADIUS	VACUUM SERVICE	WEIGHT PER FOOT
	INCHES	INCHES	PSI	PSI	INCHES	INCH/Hg	POUNDS
#							
2580-4	.19	.52	1000	4000	3.00	28	.12
2580-5	.25	.58	800	3200	3.38	28	.15
2580-6	.31	.67	650	2600	4.00	28	.17
2580-8	.41	.77	625	2500	4.62	28	.19
2580-10	.50	.92	600	2400	5.50	28	.28
2580-12	.62	1.08	550	2200	6.50	Coil*	.34
2580-16	.88	1.23	500	2000	7.38	Coil*	.36
2580-20	1.12	1.50	450	1800	9.00	Coil*	.43
2580-24	1.38	1.75	400	1600	10.50	Coil*	.51
2580-32	1.81	2.22	350	1400	13.25	Coil*	.75

FITTING REFERENCE	PAGE
SAE 37°	33
CPV	49-53
Dogleg	54-56
Flange	57-65
Split Clamp	66-67
Steel	34-38
Accessories see page Assembly	149-152
Instructions see page	167

**Construction:** Synthetic rubber tube, double textile braid reinforcement and synthetic rubber cover.  
**Application:** Fresh and salt water systems, fuel systems, oil applications and low pressure air. Ref. Technical Directive for Piping Devices – Flexible Hose Assemblies, S6430-AE-TED-010, volume 1 for sizes -4 thru -32 have been approved by individual Nav Sec letters. For more specific information on fluid applications, see page 176.  
**Operating Temperature Range:** -40°F to +200°F (-40°C to +93°C).  
 \*Internal support coil is required.

## FC163

High Pressure  
Meets MIL-H-24135/1  
Meets MIL-DTL-52471,  
TYPE 100R2



PART NUMBER	HOSE I.D.	HOSE O.D.	MAXIMUM OPERATING PRESSURE	MINIMUM BURST PRESSURE	MINIMUM BEND RADIUS	VACUUM SERVICE	WEIGHT PER FOOT
	INCHES	INCHES	PSI	PSI	INCHES	INCH/Hg	POUNDS
#							
FC163-06	.38	.84	4000	16000	5.00		.49
FC163-08	.50	.97	3500	14000	7.00		.56
FC163-10	.62	1.09	2750	11000	8.00		.63
FC163-12	.75	1.25	2250	9000	9.50	Coil*	.78
FC163-16	1.00	1.56	2000	8000	12.00	Coil*	1.08
FC163-20	1.25	2.00	1625	6500	16.50	Coil*	1.60
FC163-24	1.50	2.25	1250	5000	20.00	Coil*	1.88
FC163-32	2.00	2.75	1125	4500	25.00	Coil*	2.45

FITTING REFERENCE	PAGE
Pipe	68
SAE 37°	69
CPV	70-71
Dogleg	72
Flange	73-74
Accessories see page Assembly	149-152
Instructions see page	168

**Construction:** Synthetic rubber tube, double-wire braid reinforcement and synthetic rubber cover.  
**Application:** Hydraulics, fuel and lube oils, salt and fresh water. For more specific information on fluid applications, see page 176.  
**Operating Temperature Range:** -40°F to +200°F (-40°C to +93°C).  
 \*Internal support coil is required.

# Hose

## AE373

High Pressure  
Meets MIL-H-24135/13  
Non Mil-Spec  
Part Number FC195



PART NUMBER	HOSE I.D.	HOSE O.D.	MAXIMUM OPERATING PRESSURE	MINIMUM BURST PRESSURE	MINIMUM BEND RADIUS	VACUUM SERVICE	WEIGHT PER FOOT
	INCHES	INCHES	PSI	PSI	INCHES	INCH/Hg	POUNDS
#							
AE373-4	.25	.69	5000	20000	4.00		.31
AE373-6	.38	.84	4000	16000	5.00		.42
AE373-8	.50	.97	3500	14000	7.00		.51
AE373-10	.62	1.09	2750	11000	8.00		.59
AE373-12	.75	1.25	3000	12000	9.50		.75
AE373-16	1.00	1.56	2000	8000	12.00		1.04
AE373-20	1.25	2.00	1650	6600	16.50		1.68
AE373-24	1.50	2.25	1750	7000	20.00		1.91
AE373-32	2.00	2.75	1250	5000	25.00		2.39

FITTING REFERENCE	PAGE
Pipe	68
SAE 37°	69
CPV	70-71
Dogleg	72
Flange	73-74
Accessories see page	149-152
Assembly	
Instructions see page	168

**Construction:** AQP elastomer tube, double wire braid reinforcement and blue AQP elastomer cover.  
**Application:** High pressure hydraulics, petroleum based fluids and fire resistant types. For more specific information on fluid applications, see page 176.  
**Operating Temperature Range:** -40°F to +300°F (-40°C to +150°C).

## FC162

High Pressure  
Meets MIL-H-24135/2



PART NUMBER	HOSE I.D.	HOSE O.D.	MAXIMUM OPERATING PRESSURE	MINIMUM BURST PRESSURE	MINIMUM BEND RADIUS	VACUUM SERVICE	WEIGHT PER FOOT
	INCHES	INCHES	PSI	PSI	INCHES	INCH/Hg	POUNDS
#							
FC162-06	.38	.84	4500	18000	5.00		.46
FC162-08	.50	.97	4000	16000	7.00		.52
FC162-12	.75	1.23	3000	12000	9.50	Coil*	.82
FC162-16	1.00	1.56	3000	12000	11.00	Coil*	1.25

FITTING REFERENCE	PAGE
SAE 37°	75
CPV	76-77
Dogleg	78
Steel	79-82
Accessories see page	149-152
Assembly	
Instructions see page	168

**Construction:** Synthetic rubber tube, partial textile braid, 4-light spiral wire reinforcement, and synthetic rubber cover.  
**Application:** Hydraulics, fuel and lube oils, salt and fresh water. Particularly recommended for hydraulic systems that have high surge peaks and/or severe operating conditions. For more specific information on fluid applications, see page 176.  
**Operating Temperature Range:** -40°F to +200°F (-40°C to +100°C).  
 \*Internal support coil is required.

# Hose

## AE374

High Pressure  
 ABS Approved  
 Meets MIL-H-24135/9  
 Non Mil-Spec  
 Part Number FC254



PART NUMBER	HOSE I.D.	HOSE O.D.	MAXIMUM OPERATING PRESSURE	MINIMUM BURST PRESSURE	MINIMUM BEND RADIUS	VACUUM SERVICE	WEIGHT PER FOOT
	INCHES	INCHES	PSI	PSI	INCHES	INCH/Hg	POUNDS
AE374-8	.50	.98	7500	30000	8.00		.73
AE374-12	.75	1.26	6250	25000	11.00		1.09
AE374-16	1.00	1.51	5000	20000	12.00		1.35
AE374-20	1.25	1.80	4000	16000	16.50		2.03
AE374-24	1.50	2.11	3000	12000	20.00		2.33
AE374-32	2.00	2.68	3000	12000	25.00		3.10

FITTING REFERENCE	PAGE
SAE 37°	83
CPV	84-85
Dogleg	86
180° Return	87
Accessories see page Assembly	149-152
Instructions see page	170

**Construction:** Synthetic rubber tube, four heavy spiral wire reinforcement and synthetic rubber cover.  
**Application:** High pressure hydraulic systems. Particularly recommended for systems subjected to high surge peaks and severe operating conditions. For specific information on fluid compatibility, see page 176.  
**Operating Temperature Range:** -40°F to +250°F (-40°C to +121°C).  
**Warning:** Fittings designed for 2786/FC165 are not to be used on AE374.

## AE370

Large Bore  
 Meets MIL-H-24135/10  
 Non Mil-Spec  
 Part Number 2652



PART NUMBER	HOSE I.D.	HOSE O.D.	MAXIMUM OPERATING PRESSURE	MINIMUM BURST PRESSURE	MINIMUM BEND RADIUS	VACUUM SERVICE	WEIGHT PER FOOT
	INCHES	INCHES	PSI	PSI	INCHES	INCH/Hg	POUNDS
AE370-40	2.50	3.09	350**	1400	24.00	Coil*	2.00
AE370-48	3.00	3.59	200	800	33.00	11*	2.10
AE370-48	3.00	3.59	450**	1800**	33.00	Coil*	2.10

FITTING REFERENCE	PAGE
Pipe	35
Dogleg	54-55, 88
Steel	45, 57
Flange	57, 59, 61, 65, 89-99
Split Clamp	66-67, 100-103
108° Return	104
Accessories see page Assembly	149-152
Instructions see page	170

**Construction:** Synthetic rubber tube, textile inner braid, single steel wire braid reinforcement, outer textile braid and synthetic rubber cover.  
**Application:** Hydraulics, fuel and lube oils, fresh and salt water, low pressure air, nitrogen and butane. Approved per Technical Directive for Piping Devices – Flexible Hose Assemblies, S6430-AE-TED-010, Volume 1. AE370-40 hose utilizes segmented socket fittings only, AE370-48 hose utilizes either screw together or segmented socket fittings. For more specific information on fluid compatibility, see page 176.  
**Operating Temperature Range:** -40°F to +275°F (-40° C to +100°C).  
 \*Internal support coil is required.  
 \*\*Applicable only when using segment type Marine Fittings.

## **AE371**

**High Pressure Air  
Meets MIL-H-24135/5  
Non Mil-Spec  
Part Number 1529**

**Construction:** Synthetic rubber tube, double wire braid reinforcement, textile braid and perforated synthetic rubber cover.

**Application:** For pneumatic applications. Perforated cover prevents blistering, assures better high pressure service, and approved per Technical Directive for Piping Devices-Flexible Hose Assemblies, S6430-AE-TED-010, Volume 1. For more specific information on fluid compatibility, **see page 176.**

**Operating Temperature Range:** -40°F to +212°F (-40°C to +100°C).  
To prevent blistering when used for pneumatic applications.

\*Internal support coil is required.

## FC132

Large Bore  
Meets MIL-H-24136/4



PART NUMBER	HOSE I.D.	HOSE O.D.	MAXIMUM OPERATING PRESSURE	MINIMUM BURST PRESSURE	MINIMUM BEND RADIUS	VACUUM SERVICE	WEIGHT PER FOOT
	INCHES	INCHES	PSI	PSI	INCHES	INCH/Hg	POUNDS
#							
FC132-40	2.50	3.30	1000	4000	20.00	Coil*	2.25
FC132-48	3.00	3.80	900	3600	24.00	Coil*	2.55
FC132-64	4.00	4.86	600	2400	30.00	Sleeve*	3.15

FITTING REFERENCE	PAGE
Flange	116-119
Dogleg	122
Split Clamp	120-121
Trailpiece Assembly	123-126
Accessories see page Assembly	149-152
Instructions see page	171

**Construction:** Synthetic rubber tube and cover with four layers of synthetic yarn reinforcement for sizes -40 and -48 and six layers of synthetic yarn reinforcement for size -64.

**Application:** Fresh and salt water systems, oil applications and fuel systems. For more specific information on fluid applications, see page 176.

**Operating Temperature Range:** -40°F to +200°F (-40°C to +100°C).

\*Internal support coil or sleeve is required.

## 2580

Large Bore  
Meets MIL-H-24136/1



FITTING REFERENCE	PAGE
Flange	108-110
Split Clamp	111-113
Dogleg	114-115
Accessories see page Assembly	149-152
Instructions see page	172

**Construction:** Synthetic rubber tube, multiple layers of synthetic yarn reinforcement and synthetic rubber cover.

**Application:** Fresh and salt water systems, fuel systems, oil applications and low pressure air. Ref. Technical Directive for Piping Devices – Flexible Hose Assemblies, S6430-AE-TED-010, volume 1 for sizes -80 thru -192 have been approved by individual Nav Sec letters. For more specific information on fluid applications, see page 176.

**Operating Temperature Range:** -40°F to +200°F (-40°C to +100°C).

\*Internal support sleeve is required.

# Hose

## 150901

Large Bore  
Meets MIL-H-24135/4



PART NUMBER	HOSE I.D.	HOSE O.D.	MAXIMUM OPERATING PRESSURE	MINIMUM BURST PRESSURE	MINIMUM BEND RADIUS	VACUUM SERVICE	WEIGHT PER FOOT
	INCHES	INCHES	PSI	PSI	INCHES	INCH/Hg	POUNDS
#							
150901-40	2.50	3.09	1200	4800	26.00	Coil*	2.97
150901-48	3.00	3.59	900	3600	30.00	Coil*	3.33
150901-64	4.00	4.70	600	2400	33.00	Sleeve*	3.69

FITTING REFERENCE	PAGE
Dogleg	88
Flange	89-99
Split Clamp	100-103
180° Return	104
Accessories see page Assembly	149-152
Instructions see page	170

**Construction:** Synthetic rubber tube, textile inner braid (-64 size only), double steel wire braids reinforcement and synthetic rubber cover.  
**Application:** Petroleum based products, particularly fuel and lube oils, salt and fresh water. Approved for Technical Directive for Piping Devices – Flexible Hose Assemblies, S6430-AE-TED-010, Volume 1. For more specific information on fluid compatibility, see page 176.  
**Operating Temperature Range:** -40°F to +200°F (-40°C to +93°C).

\*Internal support coil or sleeve is required.

## 2758

Large Bore Qualified  
to MIL-H-24595



PART NUMBER	HOSE I.D.	HOSE O.D.	MAXIMUM OPERATING PRESSURE	MINIMUM BURST PRESSURE	MINIMUM BEND RADIUS	VACUUM SERVICE	WEIGHT PER FOOT
	INCHES	INCHES	PSI	PSI	INCHES	INCH/Hg	POUNDS
#							
2758-80	5.00	5.91	500	2000	42.00	Sleeve*	7.13
2758-96	6.00	6.91	350	1400	48.00	Sleeve*	8.08

FITTING REFERENCE	PAGE
Dogleg	105
Flange	105-106
Split Clamp	106-107
Accessories see page Assembly	149-152
Instructions see page	173

**Construction:** Synthetic rubber tube, spiral wire reinforcement and synthetic rubber cover.  
**Application:** Petroleum base products, particularly fuel and lube oils, salt and fresh water. Approved per Technical Directive for Piping Devices-Flexible Hose Assemblies, S6430-AE-TED-010, Volume 1. For more specific information on fluid compatibility, see page 176.  
**Operating Temperature Range:** -20°F to +150°F (-29°C to +65°C).

\*Internal support sleeve is required.

# Hose

## FC363

### Convuluted PTFE Hose Nonconductive Tube



PART NUMBER	HOSE I.D.	HOSE O.D.	MAXIMUM OPERATING PRESSURE	MINIMUM BURST PRESSURE	MINIMUM BEND RADIUS	VACUUM SERVICE	WEIGHT PER FOOT
	INCHES	INCHES	PSI	PSI	INCHES	INCH/Hg	POUNDS
FC363-08	.54	.74	1250†	5000	2.88	28	.16
FC363-12	.81	1.06	1100†	4400	3.75	28	.28
FC363-16	1.00	1.28	1000†	4000	5.00	24	.42
FC363-20	1.24	1.53	1000†	4000	6.25	20	.46
FC363-24	1.52	1.81	750†	3000	7.50	12	.55
FC363-32	2.00	2.31	500†	2000	10.00	5	.79

FITTING REFERENCE	PAGE
SAE 37°	141
Flange	141
Accessories see page	149-152

**Construction:** Convuluted nonconductive PTFE tube with stainless steel single wire braid cover.

**Application:** Chemical, food, water and waste handling, and various transfer applications. Not recommended for steam-cold water cycling. For more specific information on fluid compatibility, see page 176. Approved for U.S. Navy shipboard applications per 9505, OPR: 56Y231, Ser: 56Y23/849.

**Operating Temperature Range:** -65°F to +400°F (-54°C to +205°C).

†Steam 200 psi at +388°F max. Engineering information is available for specific critical temperature requirements, contact Eaton.

## FC364

### Convuluted PTFE Hose Conductive Tube

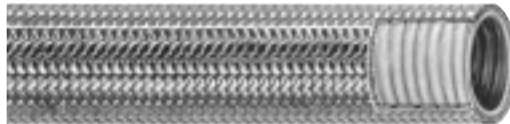

PART NUMBER	HOSE I.D.	HOSE O.D.	MAXIMUM OPERATING PRESSURE	MINIMUM BURST PRESSURE	MINIMUM BEND RADIUS	VACUUM SERVICE	WEIGHT PER FOOT
	INCHES	INCHES	PSI	PSI	INCHES	INCH/Hg	POUNDS
FC364-08	.54	.74	1250†	5000	2.88	28	.16
FC364-12	.81	1.06	1100†	4400	3.75	28	.28
FC364-16	1.00	1.27	1000†	4000	5.00	24	.42
FC364-20	1.24	1.53	1000†	4000	6.25	20	.43
FC364-24	1.52	1.81	750†	3000	7.50	12	.55
FC364-32	2.00	2.31	500†	2000	10.00	5	.79
FC364-40	2.53	2.90	100	400	12.50	5	1.35

FITTING REFERENCE	PAGE
SAE 37°	141
Flange	141
Accessories see page	149-152

**Construction:** Convuluted conductive PTFE tube with stainless steel single wire braid cover.

**Application:** Steam lines and fuel transfer applications where static dissipation is required. Not recommended for steam-cold water cycling. For more specific information on fluid compatibility, see page 176. Approved for U.S. Navy shipboard applications per 9505, OPR: 56Y231, Ser: 56Y23/849.

**Operating Temperature Range:** -65°F to +400°F (-54°C to +204°C).

†Steam 200 psi at +388°F max. Engineering information is available for specific critical temperature requirements, contact Eaton.

# Hose

## 2807

### PTFE Hose SAE 100R14



PART NUMBER	HOSE I.D.	HOSE O.D.	MAXIMUM OPERATING PRESSURE	MINIMUM BURST PRESSURE	MINIMUM BEND RADIUS	VACUUM SERVICE	WEIGHT PER FOOT
	INCHES	INCHES	PSI	PSI	INCHES	INCH/Hg	POUNDS
2807-3	.14	.25	3000†	12000	1.50	28	.04
2807-4	.19	.30	3000†	12000	2.00	28	.06
2807-5	.26	.37	3000†	12000	3.00	28	.08
2807-6	.32	.43	2500†	10000	4.00	28	.10
2807-8	.42	.54	2000†	8000	5.25	28	.12
2807-10	.51	.63	1500†	6000	6.50	28	.16
2807-12	.64	.76	1200†	4800	7.75	28	.18
2807-16	.88	1.03	1000†	4000	9.00	12*	.26
2807-20	1.12	1.29	625†	2500	16.00	12*	.35

FITTING REFERENCE	PAGE
Pipe	127
SAE 37°	128
CPV	129
Brass/Steel	130-131
Dogleg	132
Accessories see page	149-152
Assembly Instructions see page	169

**Construction:** Extruded PTFE tube, single stainless steel wire braid reinforcement cover.

**Application:** Temperature range and chemical inertness make Teflon hose suitable for a variety of applications. Some are: potable water, electronic cooling, hot lube oil, compressor discharge, saturated steam (200 psi max.), and most chemicals. For more specific information on fluid compatibility, see page 176. Approved for U.S. Navy shipboard applications per SEA 53217, 9055, Ser 312. Not recommended for steam-cold water cycling.

**Operating Temperature Range:** -100°F to +500°F (-74°C to +260°C).

†Steam 200 psi at +388° F max. Engineering is available for specific critical temperature requirements, contact Eaton.

\*Maximum negative pressures shown for -16 and larger are suitable for hose which has suffered no external damage or kinking. If greater negative pressures are required for -16 and larger hoses, the use of an internal support coil is required. Use of an internal support coil in -6 and larger Teflon hose is recommended for true support where extended or continuous service at high temperature together with low or negative pressure.

## 2808

### PTFE



PART NUMBER	HOSE I.D.	HOSE O.D.	MAXIMUM OPERATING PRESSURE	MINIMUM BURST PRESSURE	MINIMUM BEND RADIUS	VACUUM SERVICE	WEIGHT PER FOOT
	INCHES	INCHES	PSI	PSI	INCHES	INCH/Hg	POUNDS
2808-8	.42	.58	2750†	11000	4.62	28	.20
2808-10	.51	.68	2500†	10000	5.50	28	.26
2808-12	.64	.82	1750†	7000	6.50	20	.30
2808-16	.88	1.09	1500†	6000	7.38	15*	.44
2808-20	1.12	1.35	1125†	4500	11.00	15*	.57
2808-24	1.38	1.62	800†	3200	14.00	15*	.70

FITTING REFERENCE	PAGE
Pipe	133
SAE 37°	134, 138
CPV	135
Brass/Steel	136-137
Dogleg	139
Flange	140
Accessories see page	149-152
Assembly Instructions see page	169

**Construction:** Extruded PTFE tube, double-stainless steel wire braid reinforcement cover.

**Application:** Temperature range and chemical inertness make Teflon hose suitable for a variety of applications. Some are: potable water, electronic cooling, hot lube oil, compressor discharge, saturated steam (200 psi max.). For more specific information on fluid compatibility, see page 176. Preferable to 2807 hose particularly in the larger sizes when severe bending and flexing are encountered. Approved for U.S. Navy shipboard applications per SEA 53217, 9055, Ser 312. Not recommended for steam-cold water cycling.

**Operating Temperature Range:** -100°F to +450°F (-73°C to +232°C).

†Steam 200 psi at +388° F max. Engineering is available for specific critical temperature requirement, contact Eaton.

\*Maximum negative pressures shown for -16 and larger are suitable for hose which has suffered no external damage or kinking. If greater negative pressures are required for -16 and larger hoses, the use of an internal support coil is required. Use of an internal support coil in -6 and larger Teflon hose is recommended for true support where extended or continuous service at high temperature together with low or negative pressure.

# Hose

## 5000 psi Pneumatic Assemblies

ASSEMBLY NUMBER	HOSE I.D.	HOSE O.D.	MIN BEND RADIUS (INCHES)	THREAD	A	B	L
AE1002867H-L 678619-8-"L"	.44	.80	8.00	13/4-12UN-3A	2.80	2.11	Overall Assembly Length
AE1000120H-"L"	.44	.80	8.00	13/4-12UN-3A	2.52	2.11	Overall Assembly Length

All dimensions in inches

### 678619 with reusable fittings

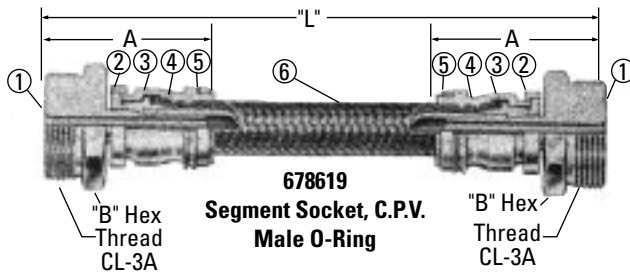

COMPONENTS 678619 SEGMENT SOCKET, C.P.V. MALE O-RING

DESCRIPTION	REQ'D PER ASS'Y	PART NUMBER	SIZE	MATERIAL
① Nipple	2	AE11495H	-8	304 Cres
② Retainer	2	AE11499H	-8	4140 Norm
③ Sleeve	2	AE11497H	-8	304 Cres
④ Socket	6	AE11496H	-8	4130 Norm
⑤ Retainer	2	AE11498H	-8	4140 Norm
⑥ Hose	1	678	-8	Teflon

#### Applications:

Aeroquip Pneumatic Teflon\* Hose Assemblies are suitable for high pressure service with inert gas systems where operating pressures reach 5500 psi (351.6 Kg/cm<sup>2</sup>). The hose is recommended for air, nitrogen and other inert gases, and is also suitable for helium and helium mixtures where a relatively high effusion rate can be accepted. Aeroquip 678 Hose is suitable in a temperature range from -65°F to +450°F. It is NOT recommended for pure oxygen lines without specific engineering approval from Eaton in each case. Primary shipboard applications include compressor discharge lines in H.P. air systems, and charging lines in air and nitrogen systems. The hose reinforcement is multiple spiral layers of 300-series stainless steel wire.

#### Lengths:

Aeroquip 678619 and AE1000120 Hose Assemblies are available in continuous lengths up to 40 feet. Longer lengths can be assembled using C.P.V. union fittings, or by specifying integral union nipple assemblies.

#### Fittings:

The standard reusable or crimped socket fittings are illustrated above with CRES components. The straight thread male C.P.V. "O" Ring style is the standard end configuration. However, a 37° flare swivel fitting and a Walseal male fitting can be supplied on special order.

### AE1000120 with crimped fittings

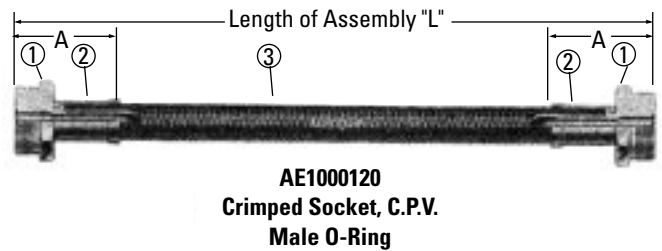

COMPONENTS AE1000120 CRIMPED SOCKET, C.P.V. MALE O-RING

DESCRIPTION	REQ'D PER ASS'Y	PART NUMBER	SIZE	MATERIAL
① Nipple	2	AE10512H	-8	304 Cres
② Socket	2	AE10513H	-8	304 Cres
③ Hose	1	678	-8	Teflon

#### Certification:

The 678619 Hose Assembly is supplied with certification. Traceability documentation to NavShips 0948-045-7010, Level 1, including heat numbers, can be supplied at additional charge when requested.

\*Teflon is a DuPont trademark.

#### How to Order:

The Aeroquip 678619 and AE1000120 Teflon Hose Assemblies should be ordered as detailed below. The complete part number will include the size (-8 only), and the overall length in inches from sealing surface to sealing surface.

#### Example:

Complete Part Number 678619 - 8 - 0143  
 Basic Assembly Number \_\_\_\_\_  
 Dash Size, 1/2" I.D. \_\_\_\_\_  
 Length, 14 inches \_\_\_\_\_  
 3 equals 3/8" \_\_\_\_\_  
 last digit in 1/8" increments

Basic Assembly Number AE1000120H - 0143  
 Dash Size, 1/2" I.D. \_\_\_\_\_  
 Length, 14 inches \_\_\_\_\_  
 3 equals 3/8" \_\_\_\_\_  
 last digit in 1/8" increments

# Hose Fittings

## Fittings Index

<b>SECTION</b>	<b>PAGES</b>
Master Index	3-6
"FH" Competitor Part Number Conversion Chart	7
Hose	8-23
Fittings	24-141
Adapters	142-144
Accessories Assembly Instructions And Assembly equipment	145-173
Technical Data	174-205

<b>HOSE</b>	<b>MALE PIPE</b>	<b>SAE 37"</b>	<b>CPV</b>	<b>DOGLEG</b>	<b>FLANGE</b>	<b>SPLIT CLAMP</b>	<b>STEEL</b>	<b>SAE 45"</b>	<b>UNIVERSAL</b>	<b>COMPRESSION TYPE</b>	<b>180° RETURN</b>
2556	26	27-29					26-32	27-29	27-29	28	
2565	26	27-29					26-32	27-29	27-29	28	
2665	Crimp Fittings Available – Please Contact Eaton										
2758				105	105-106	106-107					
2766	68	69	70-71	72	73-74						
2807	127	128	129	132			130-131				
2808	133	134,138	135	139	140		136-137				
150901				88	89-99	100-103					
2580 (4 thru 32)		33	49-53	54-56	57-65	66-67	34-38				
2580 (80 thru 192)				114-115	108-110	111-113					
303, 302A		33	49-53	54-56	57-65	66-67	34-48				
AE369		33	49-53	54-56	57-65	66-67	34-48				
AE370	35		54-55, 88		57,59,61, 65,100-103	66-67, 100-103	45,47				104
AE371	68	69	70-71	72	73-74						
AE372		33	49-53	54-56	57-65	66-67	34-48				
AE373	68	69	70-71	72	73-74						
AE374		83	84-85	86							87
FC132			122		116-119	120-121					
FC162		75	76-77	78			79-82				
FC163	68	69	70-71	72	73-74						
FC173	Fittings Available – Please Contact Eaton										
FC234		33	49-53	54-56	57-65	66-67	34-38				
FC363		141			141						
FC364		141			141						

# Hose Fittings

## How To Order

### How to order

Accurate processing and prompt delivery of your order depends on easy identification of your requirements. Please order Aeroquip parts using correct part numbers as described in this catalog. Inquiries and orders should be directed to your Eaton Aeroquip Distributor or:

Eaton  
14615 Lone Oak Road  
Eden Prairie, MN  
55344-2287  
(952) 937-7190 or  
(952) 937-7262  
Fax: (952) 937-7394  
[www.hydraulics.eaton.com](http://www.hydraulics.eaton.com)

### Part numbers and dash sizes

Dash size designates the nominal size in 16ths of an inch. This number immediately follows the part number and is separated from it with a dash.

Fittings with "FC" or "FJ" part numbers will have the size expressed in four numerals. The first two numerals indicate the size of the connecting end and the second two numerals indicate the size of the hose end. All other fittings are followed by a dash number which is the nominal size of the fitting expressed in 16ths of an inch. Where two dash numbers are given, the first one generally indicates the pipe or port size and the second indicates the tube or hose size. The hose dash number should always be the same as the last dash number on the fitting.

### Dimensions

Dimensions given in this catalog for Aeroquip products are approximate and should be used for reference only. Exact dimensional information for a given product is subject to change and varying tolerances; contact Eaton directly for full current information.

### Globally Standardized Pressure Ratings

Eaton has standardized hose burst and operating pressure ratings in cataloging, worldwide. This move toward standardization will slightly alter some of the pressures ratings listed for hoses in this catalog as pressures are rounded off. This is a paper conversion only. This action has no effect on the actual testing and certification of Aeroquip hoses to stringent product standards.



### WARNING

Eaton manufactures the terminal ends of our hose fittings to the appropriate requirements established by the SAE. Therefore, the performance ratings of these hose fittings meet the SAE requirements. It is possible to order a hose assembly with a fitting terminal end that has a performance rating lower than the hose rating. When ordering hose assemblies, please keep the terminal end performance rating in mind since this may affect overall hose assembly performance.

Many hose assembly components (hose and fittings) are easily assembled in the field. However, factory assembled swaged, crimped and reusable hose assemblies are available. For complete information, contact Eaton.

### MIXING/MATCHING

AEROQUIP FITTING TOLERANCES ARE ENGINEERED TO MATCH AEROQUIP HOSE TOLERANCES. THE USE OF AEROQUIP FITTINGS ON HOSE SUPPLIED BY OTHER MANUFACTURERS AND/OR THE USE OF AEROQUIP HOSE WITH FITTINGS SUPPLIED BY OTHER MANUFACTURERS MAY RESULT IN THE PRODUCTION OF UNRELIABLE AND UNSAFE HOSE ASSEMBLIES AND IS NEITHER RECOMMENDED NOR AUTHORIZED BY EATON.

EATON SHALL NOT BE SUBJECT TO AND DISCLAIM ANY OBLIGATIONS OR LIABILITIES (INCLUDING BUT NOT LIMITED TO ALL CON-

SEQUENTIAL, INCIDENTAL AND CONTINGENT DAMAGES) ARISING OUT OF BREACH OF CONTACT OR OF WARRANTY OR ARISING FROM TORT CLAIMS (INCLUDING WITHOUT LIMITATION NEGLIGENCE AND STRICT LIABILITY) OR OTHER THEORIES OF LAW WITH RESPECT TO ANY HOSE ASSEMBLIES NOT PRODUCED FROM GENUINE AEROQUIP HOSE FITTINGS, HOSE AND AEROQUIP APPROVED EQUIPMENT, AND IN CONFORMANCE WITH AEROQUIP PROCESS AND PRODUCT INSTRUCTIONS FOR EACH SPECIFIC HOSE ASSEMBLY.

FAILURE TO FOLLOW AEROQUIP PROCESS AND PRODUCT INSTRUCTIONS AND LIMITATIONS COULD LEAD TO PREMATURE HOSE ASSEMBLY FAILURES RESULTING IN PROPERTY DAMAGE, SERIOUS INJURY OR DEATH.

# Hose Fittings

## Reusable Fittings

### SOCKETLESS

for use with Hose  
2556, 2565

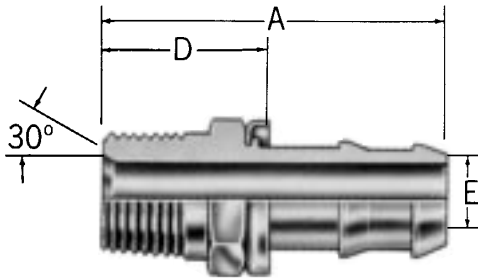

### MALE PIPE

4738-B

DASH SIZE	THREAD	HOSE SIZE	A	D	EØ
<b>4738-</b>					
2-4B	1/4-27	-04	1.40	.65	.17
4-4B	1/4-18	-04	1.58	.83	.17
4-6B	1/4-18	-06	1.76	.89	.30
6-6B	3/8-18	-06	1.76	.89	.30
6-8B	3/8-18	-08	1.91	.89	.39
8-8B	1/2-14	-08	2.16	1.14	.39
8-10B	1/2-14	-10	2.68	1.14	.48
12-12B	3/4-14	-12	2.72	1.21	.61

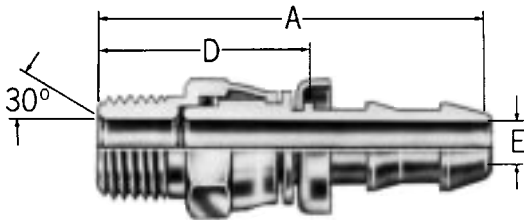

### MALE PIPE SWIVEL

FJ9068-S/FJ9486-B\*\*Uses Neoprene O-Ring

DASH SIZE	THREAD	HOSE SIZE	A	D	EØ
<b>FJ9068-</b>					
0404S	1/4-18	-04	2.19	1.43	.17
0606S	3/8-18	-06	2.30	1.43	.30
0808S	1/2-14	-08	2.70	1.69	.39
<b>FJ9486-</b>					
0204B	1/4-27	-04	1.70	.94	.12

\*\*Use only with petroleum and wateryglycol fluids.

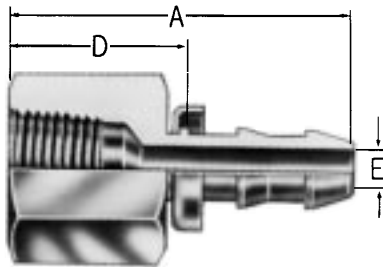

### FEMALE PIPE

4753-B

DASH SIZE	THREAD	HOSE SIZE	A	D	EØ
<b>4753-S</b>					
4-4B	1/4-18	-04	1.52	.77	.17
6-6B	3/8-18	-06	1.70	.83	.30
8-8B	1/2-14	-08	2.03	1.02	.39

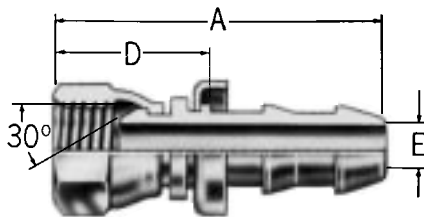

### FEMALE NPSM SWIVEL

FC5853-S

DASH SIZE	THREAD	HOSE SIZE	A	D	EØ
<b>FC5853-</b>					
0404S	1/4-18	-04	1.64	.89	.17
0606S	3/8-18	-06	1.75	.89	.30
0808S	1/2-14	-08	2.03	1.01	.39
0810S	1/2-14	-10	2.55	1.01	.48
1212S	3/4-14	-12	2.63	1.11	.61

All dimensions in inches.

# Hose Fittings

## Reusable Fittings

**SOCKETLESS**  
for use with Hose  
2556, 2565

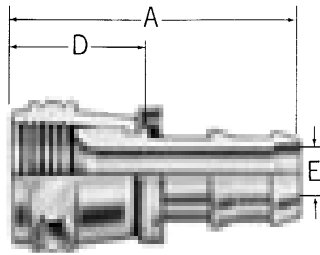

4797-B  
**UNIVERSAL†**  
4739-B  
**SAE 45°\***  
4741-B  
**SAE 37° (JIC)**

DASH SIZE	THREAD	HOSE SIZE	A	D	EØ
<b>4797-</b>					
4B†	1/16-20	-04	1.46	.71	.17
5-4B†	1/2-20	-04	1.52	.77	.17
8-6B†	3/4-16	-06	1.79	.93	.30
8B†	3/4-16	-08	1.95	.93	.39
10-8B†	1/2-14	-08	2.07	1.06	.39
10B†	1/2-14	-10	2.60	1.06	.48
<b>4739-</b>					
6B*	3/8-18	-06	1.67	.81	.30
12B*	1 1/16-14	-12	2.71	1.19	.61
<b>4741-</b>					
3-4B	3/8-24	-04	1.44	.69	.12
6-4B	1/16-18	-04	1.56	.81	.17
5-6B	1/2-20	-06	1.66	.80	.23
6B	3/16-18	-06	1.67	.80	.30
12B	1 1/16-12	-12	2.71	1.19	.61

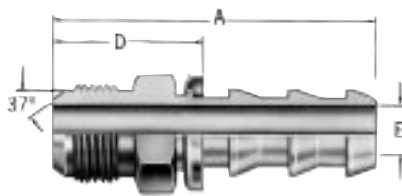

**SAE 37° (JIC) MALE FLARE**  
190672-B

DASH SIZE	THREAD	HOSE SIZE	A	D	EØ
<b>190672-</b>					
4B	1/16-20	-04	1.63	.88	.17
6B	3/16-18	-06	1.75	.89	.30

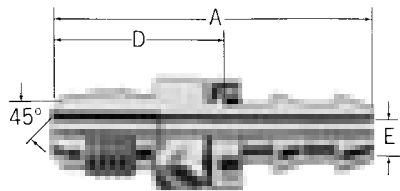

**SAE 45° MALE FLARE**  
4742-B

DASH SIZE	THREAD	HOSE SIZE	A	D	EØ
<b>4742-</b>					
4B	1/16-20	-04	1.58	.83	.17
5-4B	1/2-20	-04	1.64	.89	.17
6B	3/8-18	-06	1.82	.95	.28
8B	3/4-16	-08	2.10	1.08	.39

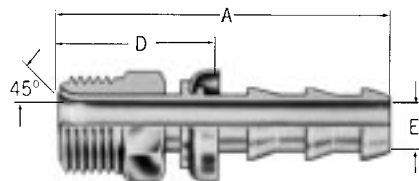

**SAE 45° INVERTED MALE FLARE**  
4740-B

DASH SIZE	THREAD	HOSE SIZE	A	D	EØ
<b>4740-</b>					
3-4B	3/8-24	-04	1.50	.75	.13
4B	1/16-24	-04	1.50	.75	.17
5-4B	1/2-20	-04	1.58	.82	.17
6B	3/8-18	-06	1.72	.86	.30
8B	3/4-18	-08	1.96	.94	.39
10B	1/2-18	-10	2.55	1.01	.48

All dimensions in inches.

†Double notch in nut for Universal type identification for both SAE 45° and 37° (JIC) connections.

\*Single notch in nut for SAE 45° identification.

# Hose Fittings

## Reusable Fittings

**SOCKETLESS**  
for use with Hose  
2556, 2565

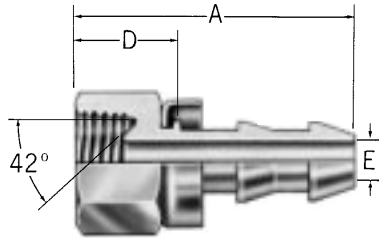

**SAE 42° INVERTED FEMALE FLARE**  
4743-B

DASH SIZE	THREAD	HOSE SIZE	A	D	EØ
<b>4743-</b>					
3-4B	3/16-24	-04	1.21	.46	.13
4B	1/16-24	-04	1.21	.46	.17
5-4B	1/2-20	-04	1.24	.49	.17
6B	3/8-18	-06	1.41	.55	.30
8-6B	3/4-18	-06	1.44	.58	.30

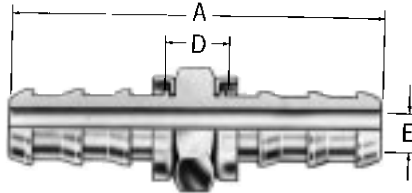

**HOSE MENDER**  
4772-B

DASH SIZE	THREAD	HOSE SIZE	A	D	EØ
<b>4772-</b>					
4B		-04	1.85	.32	.17
6B		-06	2.08	.32	.30
8B		-08	2.44	.38	.39
10B		-10	3.55	.47	.48
12B		-12	3.57	.54	.61

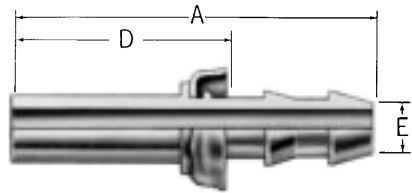

**COMPRESSION TYPE**  
4750-B

DASH SIZE	THREAD	HOSE SIZE	A	D	EØ
<b>4750-</b>					
3-4B	-03	-04	1.77	1.02	.13
4B	-04	-04	1.77	1.02	.17
5-4B	-05	-04	1.83	1.08	.17
6B	-06	-06	2.07	1.21	.30
8B	-08	-08	2.34	1.33	.39
10B	-10	-10	2.57	1.03	.48

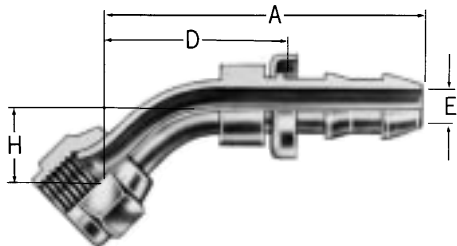

**45° ELBOW**  
FC5848S-SAE 45° swivel\*  
FC5847S-SAE 37° (JIC) swivel  
FC5849S-Universal swivel†

DASH SIZE	THREAD	HOSE SIZE	A	D	EØ	H
<b>FC5848-</b>						
0606S*	3/16-18	-06	1.80	.93	.30	.39
<b>FC5847-</b>						
0606S	3/16-18	-06	1.80	.93	.30	.39
<b>FC5849-</b>						
0404S†	1/16-20	-04	1.56	.81	.17	.33
0808S†	3/4-16	-08	2.30	1.28	.39	.55

All dimensions in inches.

†Double notch in nut for Universal type identification for both SAE 45° and 37° (JIC) connections.

\*Single notch in nut for SAE 45° identification.

# Hose Fittings

## Reusable Fittings

### SOCKETLESS

for use with Hose  
2556, 2565

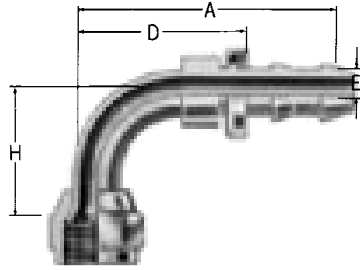

### 90° ELBOW (SHORT)

190328S–SAE 45° swivel\*  
191321S–Universal swivel†  
190516S–SAE 37° (JIC) swivel

### 90° ELBOW (LONG)

190465S–SAE 37° (JIC) swivel  
FC5852S–Universal swivel†

DASH SIZE	THREAD	HOSE SIZE	A	D	EØ	H
<b>190328–</b>						
6S*	3/8-18	–06	1.69	.83	.30	.85
<b>191321–</b>						
4S†	1/8-20	–04	1.45	.70	.17	.68
8–6S†	3/4-16	–06	1.91	1.04	.30	1.09
8S†	3/4-16	–08	2.06	1.05	.39	1.09
<b>190516–</b>						
6S	3/8-18	–06	1.70	.83	.30	.85
<b>190465–</b>						
6S	3/8-18	–06	1.70	.83	.30	2.18
<b>FC5852–</b>						
0404S†	1/8-20	–04	1.45	.70	.17	1.80

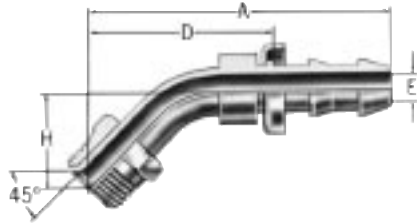

### SAE MALE INVERTED FLARE 45° ELBOW

190944–S

DASH SIZE	THREAD	HOSE SIZE	A	D	EØ	H
<b>190944–</b>						
4S	1/8-24	–04	2.46	1.70	.17	.96
6S	3/8-18	–06	2.57	1.70	.30	.96

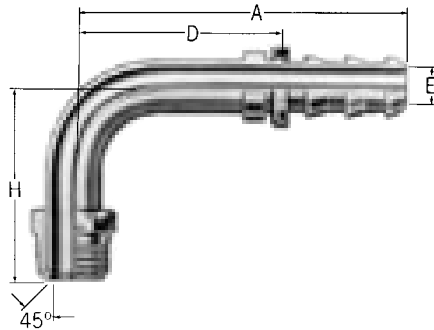

### SAE MALE INVERTED FLARE 90° ELBOW (SHORT)

190327–S

### SAE MALE INVERTED FLARE 90° ELBOW (LONG)

190326–S

DASH SIZE	THREAD	HOSE SIZE	A	D	EØ	H
<b>190327–</b>						
4S	1/8-24	–04	2.08	1.33	.17	1.69
6S	3/8-18	–06	2.20	1.33	.30	1.73
8–6S	3/4-18	–06	2.19	1.33	.30	1.74
8S	3/4-18	–08	2.34	1.33	.39	1.75
<b>190326–</b>						
6S	3/8-18	–06	3.24	2.38	.30	2.73

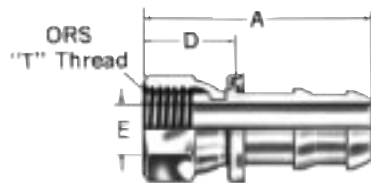

### ORS SWIVEL STRAIGHT

FJ7044–S

DASH SIZE	THREAD	HOSE SIZE	A	D	EØ
<b>FJ7044–</b>					
0404S	3/8-18	–04	1.10	.35	.17
0606S	1/8-16	–06	1.26	.39	.26
0808S	1/8-16	–08	1.50	.49	.38
1212S	1 1/8-12	–12	2.07	.55	.61

All dimensions in inches.

†Double notch in nut for Universal type identification for both SAE 45° and 37° (JIC) connections.

\*Single notch in nut for SAE 45° identification.

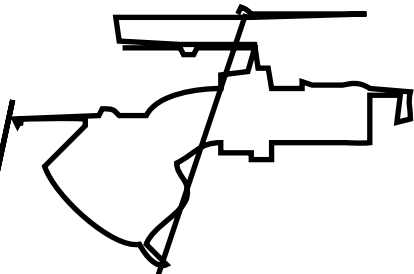

# Hose Fittings

## Reusable Fittings

### Metric **SOCKETLESS**

for use with Hose  
2556, 2565

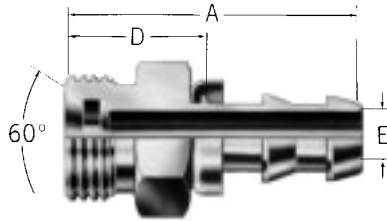

### METRIC MALE 60° DIN 7631/7647\*

07.025-

DASH SIZE	THREAD	HOSE SIZE	A	D	EØ
<b>07.025-</b>					
4-4	M12 x 1.5	-04	<b>1.50</b> 38	<b>.75</b> 19	<b>.16</b> 4.0
6-4	M14 x 1.5	-04	<b>1.50</b> 38	<b>.75</b> 19	<b>.16</b> 4.0
8-6	M16 x 1.5	-06	<b>1.61</b> 41	<b>.75</b> 19	<b>.30</b> 7.5
10-6	M18 x 1.5	-06	<b>1.61</b> 41	<b>.75</b> 19	<b>.30</b> 7.5
13-8	M22 x 1.5	-08	<b>1.85</b> 47	<b>.83</b> 21	<b>.39</b> 10.0
16-10	M26 x 1.5	-10	<b>2.40</b> 61	<b>.87</b> 22	<b>.47</b> 12.0
20-12	M30 x 1.5	-12	<b>2.59</b> 64	<b>.87</b> 22	<b>.61</b> 15.5

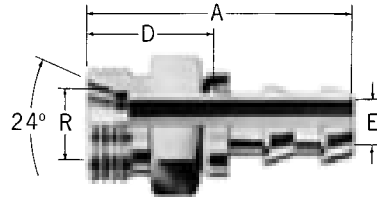

### METRIC MALE 24° DIN 3901/3902 I. RH.\*

07.021-

DASH SIZE	"T" THREAD	HOSE SIZE	A	D	EØ	RØ*
<b>07.021-</b>						
6-4	M12 x 1.5	-04	<b>1.50</b> 38	<b>.75</b> 19	<b>.16</b> 4.0	<b>.24</b> 6
8-4	M14 x 1.5	-04	<b>1.50</b> 38	<b>.75</b> 19	<b>.16</b> 4.0	<b>.31</b> 8
10-6	M16 x 1.5	-06	<b>1.65</b> 42	<b>.79</b> 20	<b>.30</b> 7.5	<b>.39</b> 10
12-6	M18 x 1.5	-06	<b>1.65</b> 42	<b>.79</b> 20	<b>.30</b> 7.5	<b>.47</b> 12
15-8	M22 x 1.5	-08	<b>1.85</b> 47	<b>.83</b> 21	<b>.39</b> 10.0	<b>.59</b> 15
18-10	M26 x 1.5	-10	<b>2.36</b> 60	<b>.83</b> 21	<b>.47</b> 12.0	<b>.71</b> 18
22-12	M30 x 2	-12	<b>2.50</b> 63.5	<b>.98</b> 25	<b>.61</b> 15.5	<b>.87</b> 22

Inches in bold type.

Millimeters in light type.

\*RØ is tube O.D. and refers to mating component when not called out on the illustration.

\*Material for metric fittings is steel.

# Hose Fittings

## Reusable Fittings

### Metric **SOCKETLESS**

for use with Hose  
2556, 2565

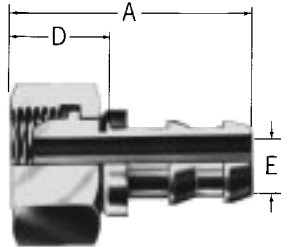

### METRIC UNIVERSAL FEMALE SWIVEL 60° DIN 7631/7647\*

07.006- / 07.001- / 07.114-

DASH SIZE	THREAD	HOSE SIZE	A	D	EØ
<b>07.006-</b>					
4-4	M12 x 1.5	-04	<b>1.48</b> 37.5	<b>.73</b> 18.5	<b>.16</b> 4.0
8-6	M16 x 1.5	-06	<b>1.63</b> 41.5	<b>.77</b> 19.5	<b>.30</b> 7.5
<b>07.001-</b>					
6-4	M14 x 1.5	-04	<b>1.38</b> 35	<b>.63</b> 16	<b>.16</b> 4.0
10-6	M18 x 1.5	-06	<b>1.52</b> 38.5	<b>.65</b> 16.5	<b>.30</b> 7.5
13-8	M22 x 1.5	-08	<b>1.83</b> 46.5	<b>.81</b> 20.5	<b>.39</b> 10.0
16-10	M26 x 1.5	-10	<b>2.24</b> 57	<b>.71</b> 18	<b>.47</b> 12.0
<b>07.114-</b>					
20-12	M30 x 1.5	-12	<b>2.22</b> 56.5	<b>.71</b> 18	<b>.61</b> 15.5

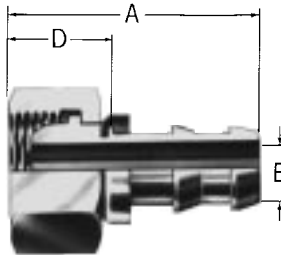

### METRIC UNIVERSAL FEMALE SWIVEL 24° DIN 3901/3902 I.RH.\*

07.006- / 07.001-

DASH SIZE	"T" THREAD	HOSE SIZE	A	D	EØ
<b>07.006-</b>					
4-4	M12x 1.5	-04	<b>1.48</b> 37.5	<b>.73</b> 18.5	<b>.16</b> 4.0
8-6	M16x 1.5	-06	<b>1.63</b> 41.5	<b>.77</b> 19.5	<b>.30</b> 7.5
<b>07.001-</b>					
6-4	M14x 1.5	-04	<b>1.38</b> 35	<b>.63</b> 16	<b>.16</b> 4.0
10-6	M18x 1.5	-06	<b>1.52</b> 38.5	<b>.65</b> 16.5	<b>.30</b> 7.5
13-8	M22x 1.5	-08	<b>1.83</b> 46.5	<b>.81</b> 20.5	<b>.39</b> 10.0
16-10	M26x 1.5	-10	<b>2.24</b> 57	<b>.71</b> 18	<b>.47</b> 12.0
22-12	M30x 2	-12	<b>2.40</b> 61	<b>.89</b> 22.5	<b>.61</b> 15.5

**Inches in bold type.**

Millimeters in light type.

\*Rø is tube O.D. and refers to mating component when not called out on the illustration.

\*Material for metric fittings is steel.

# Hose Fittings

## Medium Pressure

**S.A.E. 37°  
flare swivel  
(J.I.C.) 4-411  
MIL-F-24787/2,  
Group VIII, Type A**

for use with Hose  
302A, 303, 2580, AE369,  
AE372, FC234

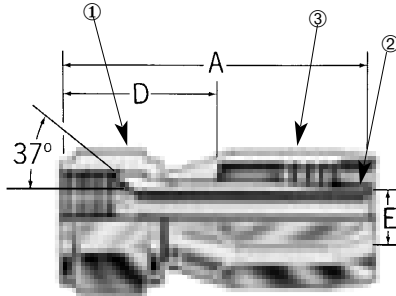

PART NUMBER*	O.D. TUBE SIZE	THREAD	A	D	E	WT. EA. (LBS.)
4-411-4*	¼	⅝-20	1.75	1.00	.17	.10
4-411-5*	⅜	½-20	1.90	1.12	.23	.12
4-411-6*	½	⅝-18	2.05	1.15	.30	.17
4-411-8*	⅝	¾-16	2.52	1.38	.39	.27
4-411-10*	¾	⅞-14	2.80	1.51	.48	.42
4-411-12*	¾	1⅛-12	3.15	1.58	.61	.57
4-411-16*	1	1⅝-12	2.82	1.55	.82	.68
4-411-20*	1¼	1⅞-12	3.00	1.64	1.05	1.29
4-411-24*	1½	1⅞-12	3.28	1.83	1.28	1.61
4-411-32*	2	2⅞-12	4.02	2.18	1.75	2.57

\*Requires assembly tool for assembly.

COMPONENTS DESCRIPTION	REQ'D. PER ASS'Y.	PART NUMBER BASE NO.	PART NUMBER SIZE										MATERIAL	MATERIAL SPECIFICATION
			4	5	6	8	10	12	16	20	24	32		
① Nut	1	4-1290-	4	5	6	8	10	12	16	20	24	32	Monel	QQ-N-281
② Nipple	1	4-1251-	4	5	6	8	10	12	16	20	24	32	Monel	QQ-N-281
③ Socket	1	4-1210-	4	5	6	8	10	12					Monel	QQ-N-281
③ Socket	1	4-1212-							16	20	24	32	Monel	QQ-N-281

# Hose Fittings

## 100R5 Style Reusable fittings

for use with Hose  
302A, 303, 2580,  
AE369, AE372, FC234

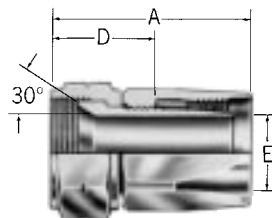
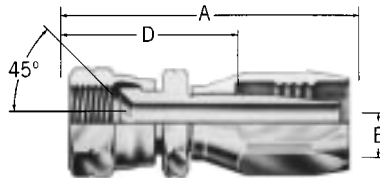
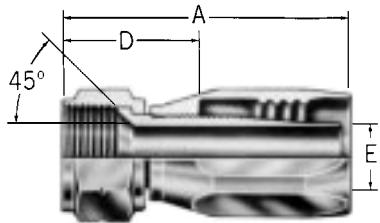
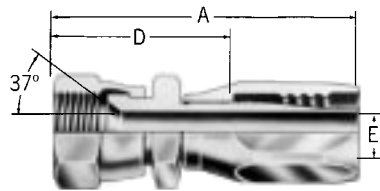

## SAE 37° (JIC) SWIVEL 4411-S

DASH SIZE	THREAD	HOSE SIZE	A	D	EØ
<b>4411-</b>					
4S†††	1/16-20	-04	1.97	1.23	.13
4-5S	1/16-20	-05	2.08	1.30	.17
5S†††	1/8-20	-05	2.12	1.35	.18
6S†††	3/16-18	-06	2.33	1.43	.24
8-6S	1/4-16	-06	2.42	1.52	.24
6-8S	3/16-18	-08	2.68	1.53	.30
8S†††	1/4-16	-08	2.78	1.62	.36
10-8S	5/16-14	-08	2.95	1.80	.36
8-10S	3/4-16	-10	2.92	1.64	.39
10S†††	5/8-14	-10	3.10	1.81	.46
12-10S	1 1/16-12	-10	3.19	1.91	.46
10-12S	3/8-14	-12	3.40	1.83	.55
12S†††	1 1/16-12	-12	3.49	1.92	.55
14-12S	1 3/16-12	-12	3.56	1.99	.55
16S†††	1 5/16-12	-16	3.19	1.93	.82
20S	1 5/8-12	-20	3.43	2.07	1.05
20-24S	1 5/8-12	-24	3.65	2.19	1.06
24S	1 7/8-12	-24	3.68	2.22	1.28
32S	2 1/2-12	-32	4.39	2.55	1.75

## SAE 45° SWIVEL†††† 401-S

DASH SIZE	THREAD	HOSE SIZE	A	D	EØ
<b>401-</b>					
4S*	1/16-20	-04	1.75	1.00	.17
5S*	1/8-20	-05	1.90	1.12	.23
6S*	3/16-18	-06	2.05	1.15	.30
8-6S*	1/4-16	-06	2.18	1.28	.30
8S*	1/4-16	-08	2.52	1.38	.39
10S*	5/16-14	-10	2.80	1.51	.48
12S*	1 1/16-14	-12	3.02	1.45	.61

## SAE 45° SWIVEL 4401-S

DASH SIZE	THREAD	HOSE SIZE	A	D	EØ
<b>4401-</b>					
4S	1/16-20	-04	1.97	1.22	.13
5S	1/8-20	-05	2.12	1.34	.17
6S	3/16-18	-06	2.36	1.46	.24
8S	1/4-16	-08	2.78	1.62	.36
10S	5/16-14	-10	3.10	1.81	.46
12S	1 1/16-14	-12	3.49	1.92	.55

## PTT SWIVEL\* 406-B

DASH SIZE	THREAD	HOSE SIZE	A	D	EØ
<b>406-</b>					
16B††††	1 1/16-14	-16	2.60	1.33	.82
20B††††	1 5/8-14	-20	2.86	1.50	1.05
24B	1 7/8-14	-24	3.13	1.67	1.28

\*Requires assembly tools for assembly.  
All dimensions in inches.

† Also supplied in brass. To order substitute "B" for "S" in part number.

†† Wet air brake system can cause fitting corrosion, if encountered use an all brass fitting (substitute "B" for "S" in part number, or steel fittings with brass nipples (add "63-" prefix and drop "S" suffix in part number).

††† Also supplies in stainless steel. To order drop the "S" suffix and add "259-" prefix.

†††† Also supplied in steel. To order drop "B" suffix and substitute "S" in part number.

# Hose Fittings

## Medium Pressure

### 100R5 Style Reusable fittings

for use with Hose  
302A, 303, 2580, AE369,  
AE370-48, AE372, FC234

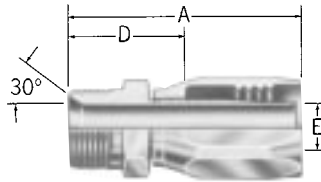

### MALE PIPE

412-S, 44-412-

DASH SIZE	THREAD	HOSE SIZE	A	D	EØ
<b>412-</b>					
†2-4S*	1/8-27	-04	1.68	.92	.17
†4-4S*	1/4-18	-04	1.86	1.11	.17
†2-5S*	1/8-27	-05	1.78	1.00	.23
†4-5S*	1/4-18	-05	1.96	1.18	.23
†4-6S*	1/4-18	-06	2.13	1.23	.30
†6-6S	3/8-18	-06	2.13	1.23	.24
†6-8S*	3/8-18	-08	2.48	1.33	.36
8-8S	1/2-14	-08	2.73	1.58	.39
†8-10S*	1/2-14	-10	2.88	1.59	.48
12-10S*	3/4-14	-10	2.94	1.65	.48
†12-12S*	3/4-14	-12	3.24	1.67	.61
†12-16S	3/4-14	-16	2.80	1.53	.82
†16-16S	1-11 1/2	-16	2.99	1.72	.82
16-20S	1-11 1/2	-20	3.20	1.84	.95
†20-20S	1 1/4-11 1/2	-20	3.23	1.87	1.05
20-24S	1 1/4-11 1/2	-24	3.58	2.12	1.28
†24-24S	1 1/2-11 1/2	-24	3.48	2.03	1.28
†32-32S	2-11 1/2	-32	4.05	2.20	1.75
<b>44-412-</b>					
40-40	2 1/2-8	-40	5.03	3.13	2.12
48-48	3-8	-48	5.09	3.19	2.69

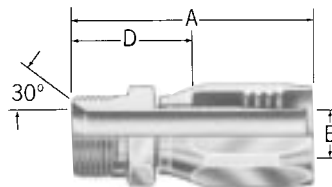

### MALE PIPE

4412-S

DASH SIZE	THREAD	HOSE SIZE	A	D	EØ
<b>4412-</b>					
2-4S	1/8-27	-04	1.68	.93	.13
4-4S	1/4-18	-04	1.87	1.12	.13
4-5S	1/4-18	-05	1.96	1.18	.17
4-6S†	1/4-18	-06	2.13	1.23	.24
6-6S	3/8-18	-06	2.13	1.23	.24
4-8S	1/4-18	-08	2.48	1.33	.30
6-8S	3/8-18	-08	2.48	1.33	.36
8-8S	1/2-14	-08	2.73	1.58	.36
8-10S	1/2-14	-10	2.88	1.59	.46
12-10S	3/4-14	-10	2.94	1.65	.46
8-12S	1/2-14	-12	3.24	1.68	.49
12-12S	3/4-14	-12	3.24	1.67	.55

† Also supplied in brass. To order substitute "B" for "S" in part number.

\*Requires assembly tools for assembly.

All dimensions in inches.

# Hose Fittings

## Medium Pressure

### 100R5 Style Reusable fittings

for use with Hose  
302A, 303, 2580, AE369,  
AE372, FC234

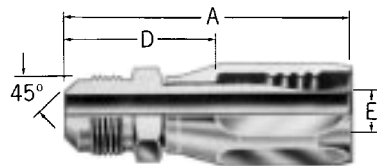
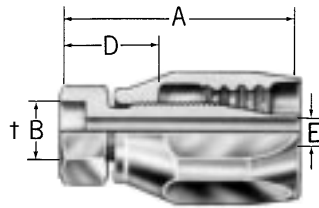
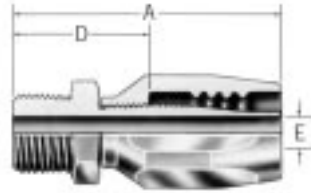

### SAE MALE O-RING BOSS

190463-S

DASH SIZE	THREAD	HOSE SIZE	A	D	EØ
<b>190463-</b>					
6S	1/16-18	-06	1.95	1.05	.24
8S	1/8-16	-08	2.35	1.20	.36
10S	1/4-14	-10	2.63	1.34	.36

### LIFESAVER†

190000-S

DASH SIZE	TUBE SIZE	HOSE SIZE	A	B†	D	EØ
<b>190000-</b>						
4S	1/4	-04	1.36	.25	.62	.13
5S	5/16	-05	1.53	.31	.75	.18
5-6S	5/16	-06	1.63	.31	.73	.24
6S	3/8	-06	1.63	.38	.73	.24
6-8S	3/8	-08	2.04	.38	.89	.28
8S	1/2	-08	2.04	.50	.89	.36
10S	5/8	-10	2.19	.62	.90	.46
8-12S	1/2	-12	2.49	.50	.92	.39
12S	3/4	-12	2.49	.75	.92	.55
16S	1	-16	2.05	1.00	.78	.82
16-20S	1	-20	2.26	1.00	.90	.82
18-20S	1 1/8	-20	2.26	1.12	.90	.94
20S	1 1/4	-20	2.26	1.25	.90	1.05
24-20S	1 1/2	-20	2.33	1.50	.96	1.05
16-24S	1	-24	2.42	1.00	.97	.82
20-24S	1 1/4	-24	2.36	1.25	.90	1.05
24-24S	1 1/2	-24	2.42	1.50	.97	1.28
20-32S	1 1/4	-32	2.89	1.25	1.05	1.06
24-32S	1 1/2	-32	2.83	1.50	.98	1.37
32-32S	2	-32	2.89	2.00	1.05	1.75
40S	2 1/2	-40	3.26	2.50	1.36	2.21

### SAE 45° MALE FLARE

4402-S

DASH SIZE	THREAD	HOSE SIZE	A	D	EØ
<b>4402-</b>					
4S††	1/16-20	-04	1.80	1.06	.13
4-5S	1/16-20	-05	1.90	1.12	.17
5S	1/8-20	-05	1.97	1.18	.17
6S††	1/8-18	-06	2.19	1.28	.24
8S††	1/4-16	-08	2.66	1.52	.36
10S††	1/4-14	-10	3.00	1.72	.46
12-10S	1/16-14	-10	3.20	1.90	.46
12S	1/16-14	-12	3.50	1.92	.56

† "B" dimension is counterbore diameter for mating tubing.

†† Available in stainless steel. To order drop the "S" suffix and add "259-" prefix.

All dimensions in inches.

## 100R5 Style Reusable fittings

for use with Hose  
302A, 303, 2580, AE369,  
AE372, FC234

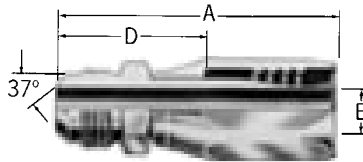

### SAE 37° (JIC) MALE FLARE

4414-S

DASH SIZE	THREAD	HOSE SIZE	A	D	EØ
<b>4414-</b>					
4S	1/16-20	-04	1.85	1.10	.13
5S	1/8-20	-05	1.95	1.17	.17
6S	3/16-18	-06	2.12	1.22	.24
8S	1/4-16	-08	2.57	1.42	.36
10S	5/16-14	-10	2.88	1.60	.46
12-10S	1 1/16-12	-10	3.05	1.76	.46
12S	1 1/16-12	-12	3.35	1.78	.55
16-12S	1 3/16-12	-12	3.40	1.83	.55
16S	1 3/16-12	-16	2.96	1.69	.82
20S	1 5/8-12	-20	3.22	1.86	1.05
24S	1 7/8-12	-24	3.44	1.99	1.28
32S	2 1/2-12	-32	4.22	2.38	1.75

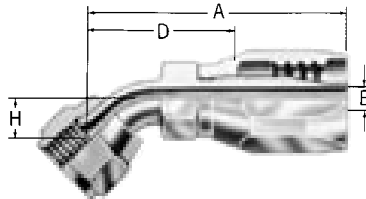

### 45° ELBOW

190297-S- Universal swivel

190299-S- SAE 45° swivel

190265-S- SAE 37° (JIC) swivel

DASH SIZE	THREAD	HOSE SIZE	A	D	EØ	H
<b>190297-</b>						
4S	1/16-20	-04	1.85	1.10	.13	.33
4-5S	1/16-20	-05	2.01	1.23	.15	.33
5S	1/8-20	-05	2.07	1.29	.18	.36
8-6S	3/16-16	-06	2.64	1.74	.24	.55
8S	3/16-16	-08	2.99	1.84	.36	.55
8-10S	3/16-16	-10	3.14	1.85	.39	.55
10S	5/16-14	-10	3.24	1.95	.46	.64
10-12S	5/16-14	-12	3.54	1.97	.48	.64
<b>190299-</b>						
6S	3/16-18	-06	2.23	1.33	.24	.39
12S	1 1/16-14	-12	3.78	2.21	.55	.78
<b>190265-</b>						
6-5S	3/16-18	-05	2.13	1.35	.17	.39
6S	3/16-18	-06	2.23	1.33	.24	.39
12S	1 1/16-12	-12	3.78	2.21	.55	.78
16-12S	1 3/16-12	-12	4.00	2.43	.55	.99
16S	1 3/16-12	-16	3.74	2.47	.82	1.07
20S	1 5/8-12	-20	4.21	2.85	1.3	.89.27

# Hose Fittings

## Medium Pressure

### 100R5 Style Reusable fittings

for use with Hose  
302A, 303, 2580, AE369,  
AE372, FC234

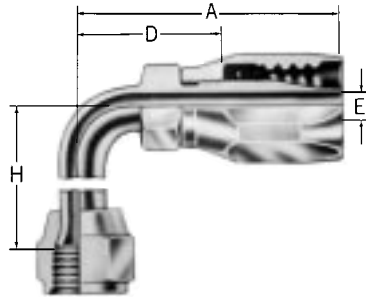

### 90° ELBOW (SHORT)

190296-S- Universal swivel  
190302-S- SAE 45° swivel  
190261-S- SAE 37° (JIC) swivel

### 90° ELBOW (LONG)

190295-S- Universal swivel  
190301-S- SAE 45° swivel  
190260-S- SAE 37° (JIC) swivel

DASH SIZE	THREAD	HOSE SIZE	A	D	EØ	H
<b>190296-</b>						
4S	3/16-20	-04	1.74	.99	.13	.68
5S	1/2-20	-05	1.96	1.18	.17	.77
8S	3/4-16	-08	2.76	1.61	.36	1.09
10S	7/8-14	-10	2.94	1.65	.46	1.23
8-12S	3/4-16	-12	3.21	1.64	.39	1.09
<b>190302-</b>						
6S	5/16-18	-06	2.13	1.23	.24	.85
12S	1 1/16-14	-12	3.74	2.17	.55	1.82
<b>190261-</b>						
6S	5/16-18	-06	2.13	1.23	.24	.85
12S	1 1/16-12	-12	3.74	2.17	.55	1.82
16-12S	1 1/8-12	-12	3.74	2.17	.55	2.14
16S	1 1/8-12	-16	3.55	2.28	.82	2.39
20-16S	1 1/2-12	-16	3.55	2.28	.76	2.50
20S	1 1/2-12	-20	4.02	2.65	1.05	2.75
20-24S	1 1/2-12	-24	4.11	2.66	1.05	2.75
<b>190295-</b>						
4S	3/16-20	-04	1.74	.99	.13	1.80
5S	1/2-20	-05	1.96	1.18	.18	1.77
8S	3/4-16	-08	2.88	1.73	.36	2.43
10S	7/8-14	-10	3.19	1.90	.46	2.57
10-12S	7/8-14	-12	3.49	1.92	2.57	.48
<b>190301-</b>						
6S	5/16-18	-06	2.13	1.23	.24	2.18
12S	1 1/16-14	-12	3.74	2.17	.55	3.73
<b>190260-</b>						
6S	5/16-18	-06	2.13	1.23	.24	2.18
12S	1 1/16-12	-12	3.74	2.17	.55	3.73
16S	1 1/8-12	-16	3.55	2.28	.82	4.58
20S	1 1/2-12	-20	4.02	2.65	1.05	5.53

# Hose Fittings

## Medium Pressure

### 100R5 Style Reusable fittings

for use with Hose  
302A, 303, 2580, AE369,  
AE372, FC234

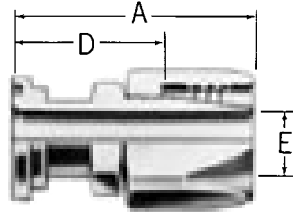

### CODE 61 SAE J518 STRAIGHT SPLIT FLANGE 4775-S

DASH SIZE	FLANGE HEAD DIA.	HOSE SIZE	A	D	EØ
<b>4775-</b>					
8S	1.19	-08	2.77	1.62	.36
8-10S	1.19	-10	3.32	2.03	.46
16-10S	1.75	-10	2.97	1.68	.46
12S	1.50	-12	3.16	1.59	.55
16-12S	1.75	-12	3.55	1.98	.55
20-12S	2.00	-12	3.55	1.98	.55
16S	1.75	-16	2.77	1.50	.82
20-16S	2.00	-16	3.36	2.09	.82
24-16S	2.38	-16	3.42	2.14	.82
16-20S	1.75	-20	2.99	1.62	.82
20S	2.00	-20	3.58	2.21	1.05
32-20S	2.81	-20	3.64	2.28	1.05
16-24S	1.75	-24	3.73	2.28	.82
20-24S	2.00	-24	3.67	2.22	1.05
24S	2.38	-24	4.02	2.56	1.28
32-24S	2.81	-24	4.02	2.56	1.28
20-32S	2.00	-32	5.26	3.42	1.06
24-32S	2.38	-32	4.42	2.58	1.37
32S	2.81	-32	4.92	3.08	1.75
40-32S	3.31	-32	4.98	3.14	1.75

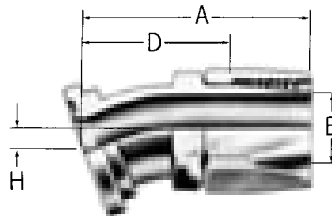

### CODE 61 SAE J518 22½° SPLIT FLANGE 4776-S

DASH SIZE	FLANGE HEAD DIA.	HOSE SIZE	A	D	EØ	H
<b>4776-</b>						
16S	1.75	-16	3.55	2.28	.82	.50
32-16S	2.81	-16	3.52	2.26	.82	.49
20S	2.00	-20	3.82	2.45	1.05	.50
32-20S	2.81	-20	3.88	2.51	1.05	.52
32S	2.81	-32	4.59	2.75	1.75	.50

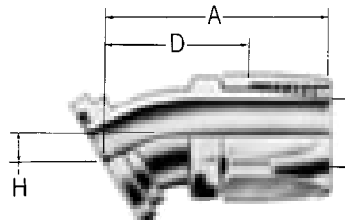

### CODE 61 SAE J518 30° SPLIT FLANGE 190846-S

DASH SIZE	FLANGE HEAD DIA.	HOSE SIZE	A	D	EØ	H
<b>190846-</b>						
16-12S	1.75	-12	3.60	2.03	.55	.45
16S	1.75	-16	3.32	2.05	.82	.50
20-16S	2.00	-16	3.32	2.05	.82	.50
20S	2.00	-20	3.63	2.26	1.05	.52
24S	2.38	-24	3.96	2.51	1.28	.58
32S	2.81	-32	4.68	2.84	1.75	.65

All dimensions in inches.

# Hose Fittings

## Medium Pressure

### 100R5 Style Reusable fittings

for use with Hose  
302A, 303, 2580, AE369,  
AE372, FC234

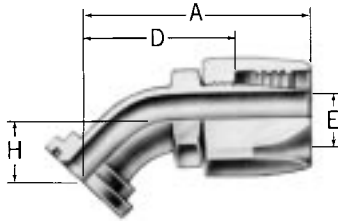

### CODE 61 SAE J518 45° SPLIT FLANGE 4777-S

DASH SIZE	FLANGE HEAD DIA.	HOSE SIZE	A	D	EØ	H
<b>4777-</b>						
8S	1.19	-08	3.44	2.30	.36	1.00
12S	1.50	-12	4.02	2.45	.55	1.00
16-12S	1.75	-12	4.02	2.45	.55	1.00
20-12S	2.00	-12	4.02	2.45	.55	1.00
16S	1.75	-16	3.80	2.53	.82	1.12
16-20S	1.75	-20	4.01	2.65	.82	1.12
20-16S	2.00	-16	3.80	2.53	.82	1.12
20S	2.00	-20	4.12	2.75	1.05	1.12
24-20S	2.38	-20	4.12	2.75	1.05	1.12
32-20S	1.81	-20	4.16	2.80	1.05	1.17
24S	2.38	-24	4.38	2.92	1.28	1.12
24-32S	2.38	-32	4.78	2.94	1.37	1.12
32-24S	2.81	-24	4.38	2.92	1.28	1.12
32S	2.81	-32	5.18	3.33	1.75	1.25
40-32S	3.31	-32	5.22	3.38	1.75	1.30

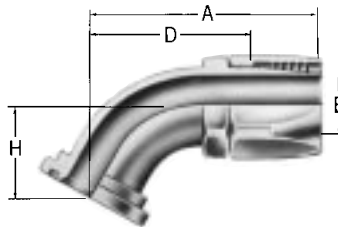

### CODE 61 SAE J518 60° SPLIT FLANGE 191395-s

DASH SIZE	FLANGE HEAD DIA.	HOSE SIZE	A	D	EØ	H
<b>191395-</b>						
12S	1.50	-12	4.15	2.58	.55	1.62
16S	1.75	-16	3.86	2.60	.82	1.64
20S	2.00	-20	4.22	2.86	1.05	1.64
24S	2.38	-24	4.73	3.28	1.28	2.00

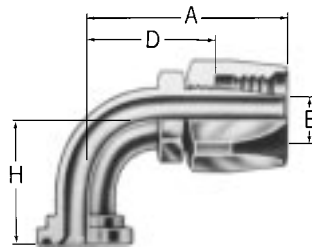

### CODE 61 SAE J518 90° SPLIT FLANGE 4779-S

DASH SIZE	FLANGE HEAD DIA.	HOSE SIZE	A	D	EØ	H
<b>4779-</b>						
8S	1.19	-08	2.88	1.73	.36	1.62
12S	1.50	-12	3.74	2.17	.55	2.12
16-12S	1.75	-12	3.74	2.17	.55	2.12
12-16S	1.50	-16	3.30	2.03	.82	2.12
16S	1.75	-16	3.55	2.28	.82	2.38
20-16S	2.00	-16	3.55	2.28	.82	2.38
16-20S	1.75	-20	3.76	2.40	.82	2.38
20S	2.00	-20	4.02	2.65	1.05	2.50
24-20S	2.38	-20	4.02	2.65	1.05	2.50
32-20S	2.81	-20	4.02	2.65	1.05	2.56
20-24S	2.00	-24	4.11	2.66	1.05	2.50
24S	2.38	-24	4.42	2.97	1.28	2.75
24-32S	2.38	-32	4.83	2.98	1.37	2.75
32S	2.81	-32	5.39	3.55	1.75	3.25
40-32S	3.31	-32	5.39	3.55	1.75	3.31

All dimensions in inches.

**100R5 Style Reusable fittings**

for use with Hose  
302A, 303, 2580, AE369,  
AE372, FC234

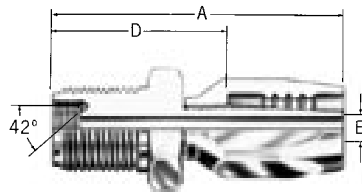
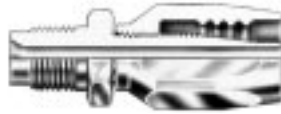

**MALE INVERTED FLARE**

190277-S

DASH SIZE	THREAD	HOSE SIZE	A	D	EØ
<b>190277-</b>					
4S	1/8-20	-04	1.80	1.05	.13

**MALE**

All dimensions in inches.

# Hose Fittings

## Medium Pressure

### 100R5 Style Reusable fittings

for use with Hose  
302A, 303, 2580, AE369,  
AE372, FC234

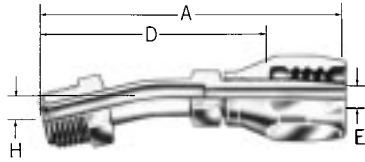

### SAE MALE INVERTED FLARE 15° ELBOW 190350-S

DASH SIZE	THREAD	HOSE SIZE	A	D	EØ	H
<b>190350-</b>						
6S	3/8-18	-06	3.26	2.36	.24	.37

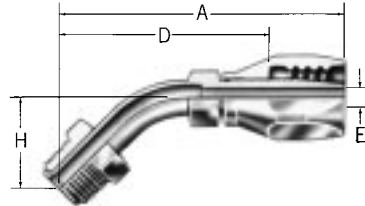

### SAE MALE INVERTED FLARE 45° ELBOW 190371-S

DASH SIZE	THREAD	HOSE SIZE	A	D	EØ	H
<b>190371-</b>						
4S	1/16-20	-04	2.74	1.99	.13	.96
5S	1/2-20	-05	2.90	2.12	.17	.96
6S	3/8-18	-06	3.00	2.10	.24	.96
8S	3/4-18	-08	3.39	2.24	.36	.93
10S	1/2-18	-10	3.74	2.44	.46	1.03

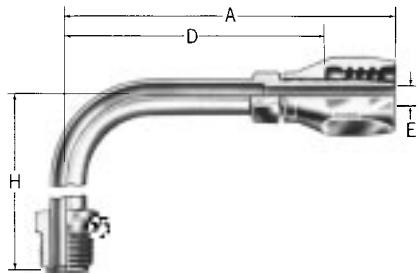

### SAE MALE INVERTED FLARE 90° ELBOW (SHORT) 190235-S

### SAE MALE INVERTED FLARE 90° ELBOW (LONG) 190325-S

DASH SIZE	THREAD	HOSE SIZE	A	D	EØ	H
<b>190235-</b>						
4S	1/16-24	-04	2.36	1.62	.13	1.69
7-4S	1/16-18	-04	2.12	1.36	.13	1.84
8-4S	3/8-18	-04	2.12	1.36	.13	1.84
5S	1/2-20	-05	2.53	1.75	.18	1.69
6S	3/8-18	-06	2.63	1.73	.24	1.73
7-6S	1/16-18	-06	2.63	1.73	.24	1.73
6-8S	3/8-18	-08	3.04	1.89	.28	1.73
7-8S	1/16-18	-08	3.04	1.89	.28	1.73
8S	3/4-18	-08	3.04	1.89	.36	1.75
10S	1/2-18	-10	3.44	2.15	.46	2.22
8-12S	3/4-18	-12	3.49	1.92	.39	1.75
<b>190325-</b>						
6S	3/8-18	-06	3.67	2.77	.24	2.73

# Hose Fittings

## Medium Pressure

### 100R5 Style Reusable fittings

for use with Hose  
302A, 303, 2580, AE369,  
AE372, FC234

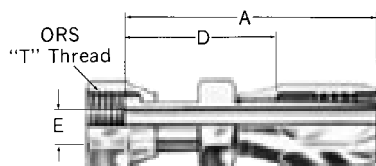

### ORS SWIVEL STRAIGHT

FJ9706-S

DASH SIZE	"T" THREAD	HOSE SIZE	A	D	EØ
<b>FJ9706-</b>					
0404S	3/16-18	-04	2.09	1.34	.13
0405S	3/16-18	-05	2.03	1.25	.17
0606S	1/4-16	-06	2.43	1.53	.24
0808S	3/8-16	-08	3.13	1.98	.36
1010S	1-14	-10	3.37	2.08	.46
1212S	1 1/16-12	-12	3.68	2.11	.55
1616S	1 1/8-12	-16	3.50	2.23	.82
2020S	1 1/4-12	-20	3.64	2.28	1.05
2424S	2-12	-24	3.86	2.40	1.26

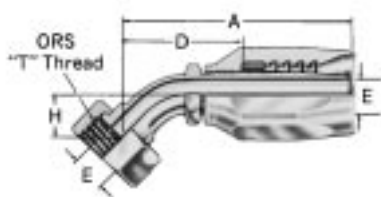

### ORS SWIVEL 45° ELBOW

FJ9707-S

DASH SIZE	"T" THREAD	HOSE SIZE	A	D	EØ	H
<b>FJ9707-</b>						
0404S	3/16-18	-04	1.96	1.21	.13	.41
0606S	1/4-16	-06	2.27	1.37	.22	.43
0806S	3/8-16	-06	2.68	1.78	.24	.59
0808S	3/8-16	-08	3.03	1.88	.36	.59
1010S	1-14	-10	3.38	2.08	.46	.65
1212S	1 1/16-12	-12	3.84	2.27	.55	.83
1616S	1 1/8-12	-16	3.62	2.35	.76	.94
2020S	1 1/4-12	-20	4.09	2.72	1.01	1.00
2424S	2-12	-24	4.32	2.87	1.26	1.07

# Hose Fittings

## Medium Pressure

### 100R5 Style Reusable fittings

for use with Hose  
302A, 303, 2580, AE369,  
AE372, FC234

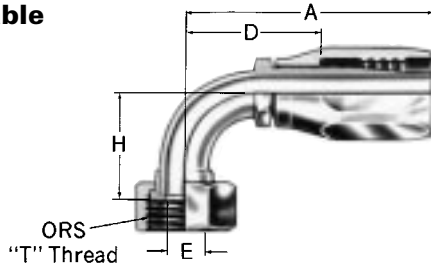

### ORS SWIVEL 90° ELBOW SHORT DROP FJ9708-S

### ORS SWIVEL 90° ELBOW LONG DROP FJ9709-S

DASH SIZE	"T" THREAD	HOSE SIZE	A	D	EØ	H
<b>FJ9708-</b>						
0404S	1/16-18	-04	1.80	1.05	.13	.82
0606S	1/16-16	-06	2.13	1.23	.22	.90
0808S	1/16-16	-08	2.76	1.61	.36	1.15
1010S	1-14	-10	3.03	1.74	.46	1.27
1212S	1/16-12	-12	3.74	2.17	.55	1.88
1616S	1/16-12	-16	3.55	2.28	.76	2.21
2020S	1 1/16-12	-20	4.02	2.65	1.01	2.51
2424S	2-12	-24	4.42	2.97	1.26	2.70
<b>FJ9709-</b>						
0404S	1/16-18	-04	1.80	1.05	.13	1.80
0606S	1/16-16	-06	2.25	1.35	.22	2.13
0808S	1/16-16	-08	2.88	1.73	.36	2.51
1010S	1-14	-10	3.03	1.74	.46	2.76
1212S	1/16-12	-12	3.74	2.17	.55	3.78
1616S	1/16-12	-16	3.55	2.27	.76	4.50
2020S	1 1/16-12	-20	4.02	2.65	1.01	5.09
2424S	2-12	-24	4.42	2.97	1.26	5.54

### BSP 100R5 Style Reusable fittings

for use with Hose  
302A, 303, 2580, AE369,  
AE372, FC234

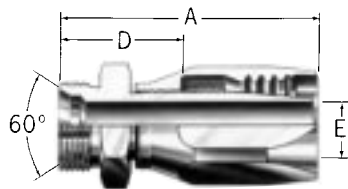

### BSP MALE\* 07.340-

DASH SIZE	THREAD	HOSE SIZE	A	D	EØ
<b>07.340-</b>					
4-4	1/4-19	-04	<b>1.83</b> 46.5	<b>1.08</b> 27.5	<b>.13</b> 3.2
6-6	3/8-19	-06	<b>2.09</b> 53	<b>1.18</b> 30	<b>.24</b> 6.0
8-8	1/2-14	-08	<b>2.52</b> 64	<b>1.35</b> 34.5	<b>.35</b> 9.0
10-10	5/8-14	-10	<b>2.80</b> 71	<b>1.50</b> 38	<b>.45</b> 11.5
12-12	3/4-14	-12	<b>3.13</b> 79.5	<b>1.56</b> 39.5	<b>.55</b> 14.0
16-16	1-11	-16	<b>2.81</b> 71.5	<b>1.54</b> 39	<b>.83</b> 21.0
20-20	1 1/4-11	-20	<b>2.91</b> 74	<b>1.56</b> 39.5	<b>1.04</b> 26.5
24-24	1 1/2-11	-24	<b>3.05</b> 77.5	<b>1.59</b> 40.5	<b>1.28</b> 32.5
32-32	2-11	-32	<b>3.76</b> 95.5	<b>1.91</b> 48.5	<b>1.75</b> 44.5

Inches in bold type

Millimeters in light type

\*Material for BSP fittings in steel.

# Hose Fittings

## Medium Pressure

### BSP 100R5 Style Reusable fittings

for use with Hose  
302A, 303, 2580, AE369,  
AE372, FC234

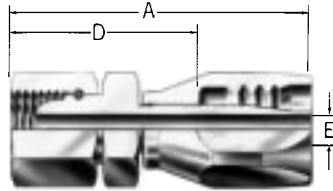

### BSP FEMALE SWIVEL\*

07.421-

DASH SIZE	THREAD	HOSE SIZE	A	D	EØ
<b>07.421-</b>					
4-4	¼-19	-04	<b>2.05</b> 52	<b>1.30</b> 33	<b>.13</b> 3.2
6-6	¾-19	-06	<b>2.34</b> 59.5	<b>1.44</b> 36.5	<b>.24</b> 6.0
8-6	½-19	-06	<b>2.40</b> 61	<b>1.50</b> 38	<b>.24</b> 6.0
8-8	½-14	-08	<b>2.76</b> 70	<b>1.59</b> 40.5	<b>.35</b> 9.0
10-10	¾-14	-10	<b>2.97</b> 75.5	<b>1.69</b> 43	<b>.45</b> 11.5
12-10	¾-14	-10	<b>3.03</b> 77	<b>1.73</b> 44	<b>.45</b> 11.5
12-12	¾-14	-12	<b>3.33</b> 84.5	<b>1.75</b> 44.5	<b>.55</b> 14.0
16-16	1-11	-16	<b>3.07</b> 78	<b>1.79</b> 45.5	<b>.83</b> 21.0
20-20	1 ¼-11	-20	<b>3.21</b> 81.5	<b>1.85</b> 47	<b>1.04</b> 26.5
24-24	1 ½-11	-24	<b>3.43</b> 87	<b>1.97</b> 50	<b>1.28</b> 32.5
32-32	2-11	-32	<b>3.98</b> 101	<b>2.13</b> 54	<b>1.75</b> 44.5

### Metric 100R5 Style Reusable fittings

for use with Hose

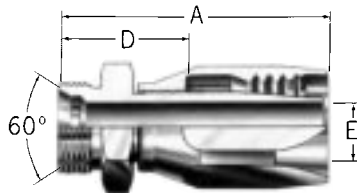

### METRIC MALE 60° DIN 7631/7647\*

07.024-

DASH SIZE	THREAD	HOSE SIZE	A	D	EØ
<b>07.024-</b>					
4-4	M12 x 1.5	-04	<b>1.77</b> 45	<b>1.02</b> 26	<b>.13</b> 3.2
6-5	M14 x 1.5	-05	<b>1.87</b> 47.5	<b>1.08</b> 27.5	<b>.18</b> 4.5
8-6	M16 x 1.5	-06	<b>1.97</b> 50	<b>1.06</b> 27	<b>.24</b> 6.0
10-8	M18 x 1.5	-08	<b>2.32</b> 59	<b>1.18</b> 30	<b>.35</b> 9.0
13-10	M22 x 1.5	-10	<b>2.56</b> 65	<b>1.26</b> 32	<b>.45</b> 11.5
16-12	M26 x 1.5	-12	<b>2.85</b> 72.5	<b>1.28</b> 32.5	<b>.55</b> 14.0
20-16	M30 x 1.5	-16	<b>2.48</b> 63	<b>1.22</b> 31	<b>.83</b> 21.0
25-20	M38 x 1.5	-20	<b>2.66</b> 67.5	<b>1.30</b> 33	<b>1.04</b> 26.5
32-24	M45 x 1.5	-24	<b>2.76</b> 70	<b>1.30</b> 33	<b>1.28</b> 32.5
40-32	M52 x 1.5	-32	<b>3.31</b> 84	<b>1.46</b> 37	<b>1.28</b> 44.5
50-32	M65 x 2	-32	<b>3.42</b> 87	<b>1.57</b> 40	<b>1.75</b> 44.5
60-40	M78 x 2	-40	<b>3.72</b> 94.5	<b>1.81</b> 46	<b>2.20</b> 56.0
70-48	M90 x 2	-48	<b>3.96</b> 100.5	<b>2.05</b> 52	<b>2.80</b> 71.0

Inches in bold type

Millimeters in light type

\*Material for BSP and metric fittings in steel.

# Hose Fittings

## Medium Pressure

### Metric 100R5 Style Reusable fittings

for use with Hose  
302A, 303, 2580, AE369,  
AE372, FC234

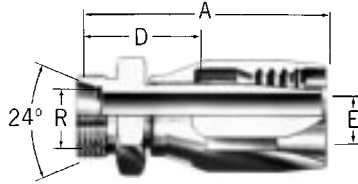

### METRIC MALE 24° DIN 3901/3902 I.R.H.\*

DASH SIZE	THREAD	HOSE SIZE	A	D	EØ	RØ*
<b>07.003-</b>						
6-4	M12x 1.5	-04	<b>1.77</b> 45	<b>1.02</b> 26	<b>.13</b> 3.2	<b>.24</b> 6
8-5	M14x 1.5	-05	<b>1.87</b> 47.5	<b>1.08</b> 27.5	<b>.18</b> 4.5	<b>.31</b> 8
10-6	M16x 1.5	-06	<b>2.01</b> 51	<b>1.10</b> 28	<b>.24</b> 6.0	<b>.39</b> 10
12-6	M18x 1.5	-06	<b>2.01</b> 51	<b>1.10</b> 28	<b>.24</b> 6.0	<b>.47</b> 12
12-8	M18x 1.5	-08	<b>2.36</b> 60	<b>1.20</b> 30.5	<b>.35</b> 9.0	<b>.47</b> 12
15-10	M22x 1.5	-10	<b>2.56</b> 65	<b>1.26</b> 32	<b>.45</b> 11.5	<b>.59</b> 15
18-10	M26x 1.5	-10	<b>2.56</b> 65	<b>1.26</b> 32	<b>.45</b> 11.5	<b>.71</b> 18
18-12	M26x 1.5	-12	<b>2.85</b> 72.5	<b>1.28</b> 32.5	<b>.55</b> 14.0	<b>.71</b> 18
22-16	M30x 2	-16	<b>2.56</b> 65	<b>1.28</b> 32.5	<b>.83</b> 21.0	<b>.87</b> 22
28-20	M36x 2	-20	<b>2.66</b> 67.5	<b>1.30</b> 33	<b>1.04</b> 26.5	<b>1.10</b> 28
35-24	M45x 2	-24	<b>2.83</b> 72	<b>1.38</b> 35	<b>1.28</b> 32.5	<b>1.38</b> 35
42-32	M52x 2	-32	<b>3.38</b> 86	<b>1.54</b> 39	<b>1.75</b> 44.5	<b>1.65</b> 42

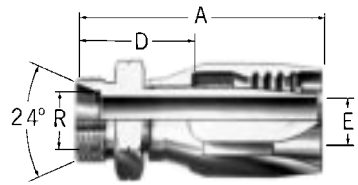

### METRIC MALE 24° DIN 3901/3902 S.R.H.\*

DASH SIZE	THREAD	HOSE SIZE	A	D	EØ	RØ*
<b>07.026-</b>						
8-4	M16x 1.5	-04	<b>1.85</b> 47	<b>1.10</b> 28	<b>.13</b> 3.2	<b>.31</b> 8
10-5	M18x 1.5	-05	<b>1.95</b> 49.5	<b>1.16</b> 29.5	<b>.18</b> 4.5	<b>.39</b> 10
12-6	M20x 1.5	-06	<b>2.05</b> 52	<b>1.14</b> 29	<b>.24</b> 6.0	<b>.47</b> 12
14-8	M22x 1.5	-08	<b>2.48</b> 63	<b>1.32</b> 33.5	<b>.35</b> 9.0	<b>.55</b> 14
16-10	M24x 1.5	-10	<b>2.64</b> 67	<b>1.34</b> 34	<b>.45</b> 11.5	<b>.63</b> 16
20-12	M30x 2	-12	<b>3.09</b> 78.5	<b>1.52</b> 38.5	<b>.55</b> 14.0	<b>.79</b> 20
25-16	M36x 2	-16	<b>2.72</b> 69	<b>1.44</b> 36.5	<b>.83</b> 21.0	<b>.98</b> 25
30-20	M42x 2	-20	<b>2.89</b> 73.5	<b>1.54</b> 39	<b>1.04</b> 26.5	<b>1.18</b> 30
38-24	M52x 2	-24	<b>3.15</b> 80	<b>1.69</b> 43	<b>1.28</b> 32.5	<b>1.50</b> 38

#### Inches in bold type

Millimeters in light type

\*Material for metric fittings in steel.

†RØ is tube O.D. and refers to mating component when not called out on the illustration.

# Hose Fittings

## Medium Pressure

### Metric 100R5 Style Reusable fittings

for use with Hose  
302A, 303, 2580, AE369,  
AE370-48, AE372, FC234

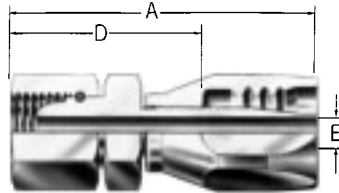

### METRIC UNIVERSAL FEMALE SWIVEL 60° DIN 7631/7647

07.002-07.036-

DASH SIZE	THREAD	HOSE SIZE	A	D	EØ
<b>07.002-</b>					
4-4	M12x 1.5	-04	<b>2.01</b> 51	<b>1.26</b> 32	<b>.13</b> 3.2
6-5	M14x 1.5	-05	<b>2.11</b> 53.5	<b>1.32</b> 33.5	<b>.18</b> 4.5
8-6	M16x 1.5	-06	<b>2.22</b> 56.5	<b>1.32</b> 33.5	<b>.24</b> 6.0
10-8	M18x 1.5	-08	<b>2.64</b> 67	<b>1.48</b> 37.5	<b>.35</b> 9.0
13-10	M22x 1.5	-10	<b>2.87</b> 73	<b>1.59</b> 40.5	<b>.45</b> 11.5
16-12	M26x 1.5	-12	<b>3.29</b> 83.5	<b>1.71</b> 43.5	<b>.55</b> 14.0
<b>07.036-</b>					
20-16	M30x 1.5	-16	<b>2.85</b> 72.5	<b>1.61</b> 40.9	<b>.83</b> 21.0
25-20	M38x 1.5	-20	<b>3.01</b> 76.5	<b>1.65</b> 42	<b>1.04</b> 26.5
32-24	M45x 1.50	-24	<b>3.23</b> 82	<b>1.77</b> 45	<b>1.28</b> 3.25
40-32	M52x 1.5	-32	<b>3.68</b> 93.5	<b>1.83</b> 46.5	<b>1.75</b> 44.5
50-32	M65x 2	-32	<b>3.68</b> 93.5	<b>1.83</b> 46.5	<b>1.75</b> 44.5
60-40	M78x 2	-40	<b>4.06</b> 103	<b>2.15</b> 54.5	<b>2.20</b> 56.0
70-48	M90x 2	-48	<b>4.27</b> 108.5	<b>2.36</b> 60	<b>2.80</b> 71.0

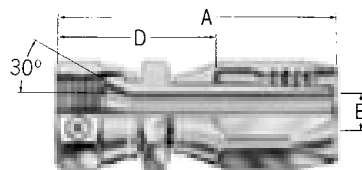

### KOMATSU 30° METRIC FEMALE SWIVEL

FC5954-S

DASH SIZE	THREAD	HOSE SIZE	A	D	EØ
<b>FC5954-</b>					
0306S	M18x 1.5	-06	<b>2.49</b> 63.3	<b>1.59</b> 40.4	<b>.24</b> 6.1
0410S	M22x 1.5	-10	<b>3.10</b> 78.7	<b>1.82</b> 46.2	<b>.37</b> 9.4
0512S	M24x 1.5	-12	<b>3.55</b> 90.2	<b>1.98</b> 50.3	<b>.48</b> 12.2
0612S	M30x 1.5	-12	<b>3.76</b> 95.5	<b>2.19</b> 55.6	<b>.55</b> 14
1016S	M33x 1.5	-16	<b>3.55</b> 90.2	<b>2.28</b> 57.9	<b>.82</b> 20.8
1424S	M42x 1.5	-24	<b>4.12</b> 107.7	<b>2.67</b> 67.8	<b>1.19</b> 30.2

Inches in bold type

Millimeters in light type

Material for metric fittings in steel.

# Hose Fittings

## Medium Pressure

### Metric 100R5 Style Reusable fittings

for use with Hose  
302A, 303, 2580, AE369,  
AE372, FC234

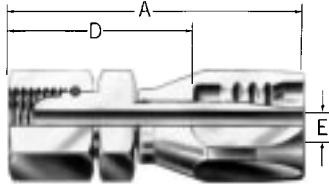

### METRIC UNIVERSAL FEMALE SWIVEL 24° DIN 3901/3902 L.RH. 07.002-

DASH SIZE	THREAD	HOSE SIZE	A	D	EØ
<b>07.002-</b>					
4-4	M12 x 1.5	-04	<b>2.01</b> 51	<b>1.26</b> 32	<b>.13</b> 3.2
6-5	M14 x 1.5	-05	<b>2.11</b> 53.5	<b>1.32</b> 33.5	<b>.18</b> 4.5
8-6	M16 x 1.5	-06	<b>2.22</b> 56.5	<b>1.32</b> 33.5	<b>.24</b> 6.0
10-8	M18 x 1.5	-08	<b>2.64</b> 67	<b>1.48</b> 37.5	<b>.35</b> 9.0
13-10	M22 x 1.5	-10	<b>2.87</b> 73	<b>1.59</b> 40.5	<b>.45</b> 11.5
16-12	M26 x 1.5	-12	<b>3.29</b> 83.5	<b>1.71</b> 43.5	<b>.55</b> 14.0
22-16	M30 x 2	-16	<b>2.91</b> 74	<b>1.63</b> 41.5	<b>.83</b> 21.0
28-20	M36 x 2	-20	<b>3.07</b> 78	<b>1.71</b> 43.5	<b>1.04</b> 26.5
35-24	M45 x 2	-24	<b>3.21</b> 81.5	<b>1.75</b> 44.5	<b>1.28</b> 32.5
42-32	M52 x 2	-32	<b>3.70</b> 94	<b>1.85</b> 47	<b>1.75</b> 44.5

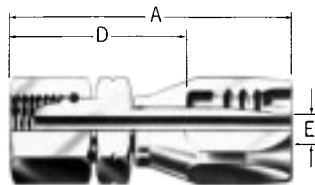

### METRIC UNIVERSAL FEMALE SWIVEL 24° DIN 3901/3902 S.RH. 07.155-

DASH SIZE	THREAD	HOSE SIZE	A	D	EØ
<b>07.155-</b>					
8-4	M16 x 1.5	-04	<b>2.07</b> 52.5	<b>1.32</b> 33.5	<b>.13</b> 3.2
10-5	M18 x 1.5	-05	<b>2.17</b> 55	<b>1.38</b> 35	<b>.18</b> 4.5
12-6	M20 x 1.5	-06	<b>2.34</b> 59.5	<b>1.44</b> 36.5	<b>.24</b> 6.0
14-8	M22 x 1.5	-08	<b>2.70</b> 68.5	<b>1.54</b> 39	<b>.35</b> 9.0
16-10	M24 x 1.5	-10	<b>2.93</b> 74.5	<b>1.63</b> 41.5	<b>.45</b> 11.5
20-12	M30 x 2	-12	<b>3.37</b> 85.5	<b>1.79</b> 45.5	<b>.55</b> 14.0
25-16	M36 x 2	-16	<b>2.95</b> .75	<b>1.67</b> 42.5	<b>.83</b> 21.0
30-20	M42 x 2	-20	<b>3.09</b> 78.5	<b>1.73</b> 44	<b>1.04</b> 26.5
38-24	M52 x 2	-24	<b>3.31</b> 84	<b>1.85</b> 47	<b>1.28</b> 32.5

Inches in bold type

Millimeters in light type

Material for metric fittings in steel.

# Hose Fittings

## Medium Pressure

### Male "O" Ring seal union (C.P.V.) 4-190911, 375-190911 MIL-F-24787/3 Group VIII Type C

for use with Hose 302A, 303, 2580,  
AE369, AE372, FC234

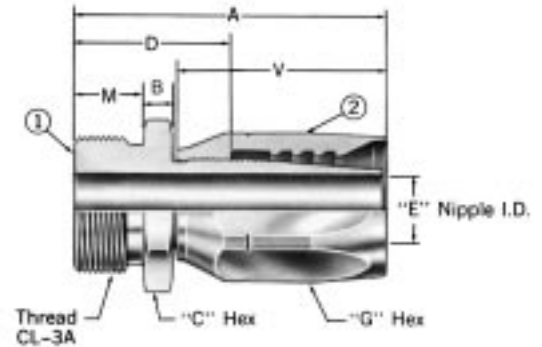

PART NUMBER	I.P.S. SIZE	THREAD	A	B	C	D	E	G	M	V	WT. EA. (LBS.)
4-190911- $\frac{1}{8}$ -6	$\frac{1}{8}$	1-14	2.06	.25	1.06	1.16	.24	.81	.50	1.30	.28
4-190911- $\frac{1}{4}$ -8	$\frac{1}{4}$	1 $\frac{3}{16}$ -12	2.54	.25	1.25	1.39	.36	.94	.62	1.65	.46
4-190911- $\frac{3}{8}$ -10	$\frac{3}{8}$	1 $\frac{3}{8}$ -12	2.75	.31	1.44	1.46	.46	1.12	.62	1.80	.65
4-190911- $\frac{1}{2}$ -12	$\frac{1}{2}$	1 $\frac{3}{4}$ -12	3.12	.38	1.81	1.55	.55	1.25	.62	2.10	1.03
375-190911- $\frac{3}{4}$ -16	$\frac{3}{4}$	2-12	2.80	.50	2.12	1.53	.61	1.44	.62	1.66	1.54
375-190911-1-20	1	2 $\frac{5}{16}$ -12	3.14	.62	2.38	1.77	.81	1.75	.75	1.75	2.38
375-190911-1 $\frac{1}{4}$ -24	1 $\frac{1}{4}$	2 $\frac{3}{4}$ -12	3.23	.62	2.88	1.78	1.25	1.94	.75	1.84	3.06
375-190911-1 $\frac{1}{2}$ -32	1 $\frac{1}{2}$	3 $\frac{1}{16}$ -12	3.89	.75	3.12	2.05	1.39	2.44	.88	2.25	4.36

COMPONENTS DESCRIPTION	REQ'D. PER ASS'Y.	PART NUMBER BASE NO.	SIZE								MATERIAL	MATERIAL SPECIFICATION	
			$\frac{1}{8}$ -6	$\frac{1}{4}$ -8	$\frac{3}{8}$ -10	$\frac{1}{2}$ -12	$\frac{3}{4}$ -16	1-20	1 $\frac{1}{4}$ -24	1 $\frac{1}{2}$ -32			
① Nipple	1	4-220779-	$\frac{1}{8}$ -6	$\frac{1}{4}$ -8	$\frac{3}{8}$ -10	$\frac{1}{2}$ -12						Monel	QQ-N-281
① Nipple	1	188-220779-					$\frac{3}{4}$ -16	1-20	1 $\frac{1}{4}$ -24	1 $\frac{1}{2}$ -32		Alum. Bronze	C95800
② Socket	1	4-1210-	6	8	10	12						Monel	QQ-N-281
② Socket	1	4-1212-						16	20	24	32	Monel	QQ-N-281
*Buna-N "O" Ring	1	22550	11	114	210	212	214	217	222	224		Buna-N	
*Butyl "O" Ring	1	22015-	11	114	210	212	214	217	222	224		Butyl	

All dimensions in inches.

Dimensional information is for reference only.

Variations from these dimensions, on actual parts, may occur as the result of engineering revisions.

\*\*"O" Ring not furnished with this assembly. Must be ordered separately.

# Hose Fittings

## Medium Pressure

### Male O-Ring seal union (C.P.V.) 66-190911, 93-190911 MIL-F-24787/3, Group VIII, Type C

for use with Hose 302A, 303, 2580,  
AE369, AE372, FC234

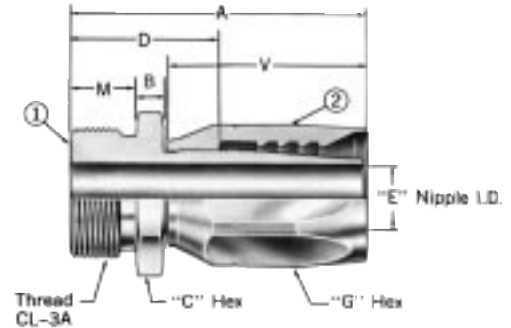

PART NUMBER	I.P.S. SIZE	THREAD	A	B	C	D	E	G	M	V	WT. EA. (LBS.)
93-190911-1/8-6	1/8	1-14	2.06	.25	1.06	1.16	.24	.81	.50	1.30	.28
93-190911-1/4-8	1/4	1 1/16-12	2.54	.25	1.25	1.39	.36	.94	.62	1.65	.46
93-190911-3/8-10	3/8	1 3/8-12	2.75	.31	1.44	1.46	.46	1.12	.62	1.80	.64
93-190911-1/2-12	1/2	1 3/4-12	3.12	.38	1.81	1.55	.55	1.25	.62	2.10	1.01
66-190911-3/4-16	3/4	2-12	2.80	.50	2.12	1.53	.61	1.44	.62	1.66	1.52
66-190911-1-20	1	2 5/16-12	3.14	.62	2.38	1.77	.81	1.75	.75	1.75	2.35
66-190911-1 1/4-24	1 1/4	2 3/4-12	3.23	.62	2.88	1.78	1.25	1.94	.75	1.84	2.91
66-190911-1 1/2-32	1 1/2	3 1/8-12	3.89	.75	3.12	2.05	1.39	2.44	.88	2.25	4.10

COMPONENTS	REQ'D. PER ASS'Y.	PART NUMBER	SIZE								MATERIAL SPECIFICATION		
			BASE NO.	1/8-6	1/4-8	3/8-10	1/2-12	3/4-16	1-20	1 1/4-24	1 1/2-32		
① Nipple	1	4-220779-		1/8-6	1/4-8	3/8-10	1/2-12					Monel	QQ-N-281
① Nipple	1	188-220779-						3/4-16	1-20	1 1/4-24	1 1/2-32	Alum. Bronze	C95800
② Socket	1	1210-	6B	8B	10B	12B						Brass	
② Socket	1	1212-						16B	20B	24B	32B	Brass	
*Buna-N O-Ring	1	22550	11	114	210	212	214	217	222	224		Buna-N	
*Butyl O-Ring	1	22015-	11	114	210	212	214	217	222	224		Butyl	

All dimensions in inches.

Dimensional information is for reference only.

Variations from these dimensions, on actual parts, may occur as the result of engineering revisions.

\*O-Ring not furnished with this assembly. Must be ordered separately.

# Hose Fittings

## Medium Pressure

### Male O-Ring seal union (C.P.V.) 411-190911

for use with Hose 302A, 303, 2580,  
AE369, AE372, FC234

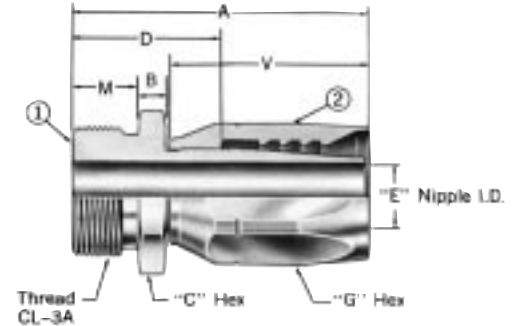

PART NUMBER	I.P.S. SIZE	THREAD	A	B	C	D	E	G	M	V	WT. EA. (LBS.)
411-190911- $\frac{3}{8}$ -10	$\frac{3}{8}$	1 $\frac{3}{8}$ -12	2.75	.31	1.44	1.46	.46	1.12	.62	1.80	.65
411-190911- $\frac{1}{2}$ -12	$\frac{1}{2}$	1 $\frac{3}{4}$ -12	3.12	.38	1.81	1.55	.55	1.25	.62	2.10	1.02
411-190911- $\frac{3}{4}$ -16	$\frac{3}{4}$	2-12	2.80	.50	2.12	1.53	.61	1.44	.62	1.66	1.54

COMPONENTS DESCRIPTION	REQ'D. PER ASS'Y.	PART NUMBER BASE NO.	SIZE			MATERIAL	MATERIAL SPECIFICATION
			$\frac{3}{8}$ -10	$\frac{1}{2}$ -12	$\frac{3}{4}$ -16		
① Nipple	1	408-220779	$\frac{3}{8}$ -10	$\frac{1}{2}$ -12	$\frac{3}{4}$ -16	Stainless Steel	316
② Socket	1	4-1210-	10	12		Monel	QQ-N-281
② Socket	1	4-1212-			16	Monel	QQ-N-281
*Buna-N O-Ring	1	22550	210	212	214	Buna-N	
*Butyl O-Ring	1	22015-	210	212	214	Butyl	

All dimensions in inches.

Dimensional information is for reference only.

Variations from these dimensions, on actual parts, may occur as the result of engineering revisions.

\*O-Ring not furnished with this assembly. Must be ordered separately.

# Hose Fittings

## Medium Pressure

### Male O-Ring seal union (C.P.V.) 90° 4-191301

#### MIL-F-24787/3, Group III, Type CL

for use with Hose 302A, 303, 2580,  
AE369, AE372, FC234

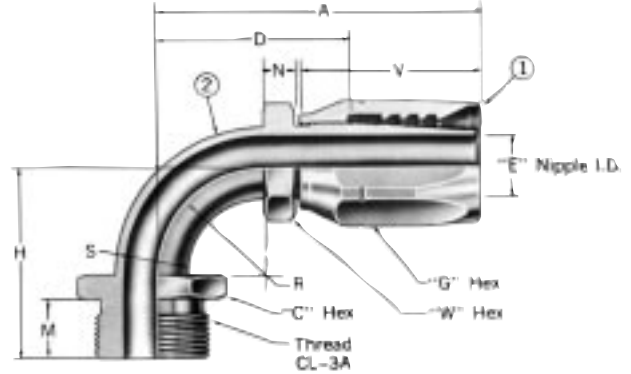

PART NUMBER	I.P.S. SIZE	THREAD	A	C	D	E	G	H	M	N	R	S	V	W	WT. EA. (LBS.)
4-191301-1/8-6	1/8	1-14	2.45	1.06	1.55	.24	.81	1.30	.50	.58	.50	.38	1.30	.56	.35
4-191301-1/4-8	1/4	1 1/8-12	3.05	1.25	1.90	.36	.94	1.68	.62	.58	.75	.50	1.65	.75	.57
4-191301-3/8-10	3/8	1 1/8-12	3.57	1.44	2.28	.46	1.12	1.99	.62	.70	1.00	.62	1.80	.81	.83
4-191301-1/2-12	1/2	1 1/4-12	4.15	1.81	2.58	.55	1.25	2.31	.62	.74	1.25	.75	2.10	1.00	1.34
4-191301-3/4-16	3/4	2-12	3.93	2.12	2.66	.82	1.44	2.68	.62	.70	1.50	1.00	1.66	1.38	2.01
4-191301-1-20	1	2 5/8-12	4.27	2.38	2.91	1.05	1.75	3.17	.75	.70	1.75	1.25	1.75	1.62	3.03
4-191301-1 1/4-24	1 1/4	2 3/4-12	4.65	2.88	3.19	1.28	1.94	3.42	.75	.74	2.00	1.50	1.84	1.81	3.95
4-191301-1 1/2-32	1 1/2	3 1/8-12	5.68	3.12	3.84	1.75	2.44	4.05	.88	.86	2.50	2.00	2.25	2.38	5.42

COMPONENTS DESCRIPTION	REQ'D. PER ASS'Y.	PART NUMBER BASE NO.	PART NUMBER SIZE								MATERIAL	MATERIAL SPECIFICATION	
			1/8-6	1/4-8	3/8-10	1/2-12	3/4-16	1-20	1 1/4-24	1 1/2-32			
① Socket	1	4-1210-	6	8	10	12						Monel	QQ-N-281
① Socket	1	4-1212-					16	20	24	32		Monel	QQ-N-281
② Nipple Assembly	1	4-186301-	1/8-6	1/4-8	3/8-10	1/2-12	3/4-16	1-20	1 1/4-24	1 1/2-32		see below	see below
Nipple	1	4-921641-	6	8	10	12	16	20	24	32		Monel	QQ-N-281
Elbow	1	4-419037-	6	8	10	12						Monel	MIL-T-1368
Elbow	1	15-419037-					16	20	24	32		Copper Nickel	MIL-T-16420
Adapter	1	4-73461-	1/8-6	1/4-8	3/8-10	1/2-12	3/4-16	1-20	1 1/4-24	1 1/2-32		Monel	QQ-N-281
*Buna-N O-Ring	1	22550	11	114	210	212	214	217	222	224		Buna-N	
*Butyl O-Ring	1	22015-	11	114	210	212	214	217	222	224		Butyl	

All dimensions in inches.

Dimensional information is for reference only.

Variations from these dimensions, on actual parts, may occur as the result of engineering revisions.

\*O-Ring not furnished with this assembly. Must be ordered separately.

# Hose Fittings

## Medium Pressure

### Male O-Ring seal union (C.P.V.) 90° 93-191301

for use with Hose 302A, 303, 2580,  
AE369, AE372, FC234

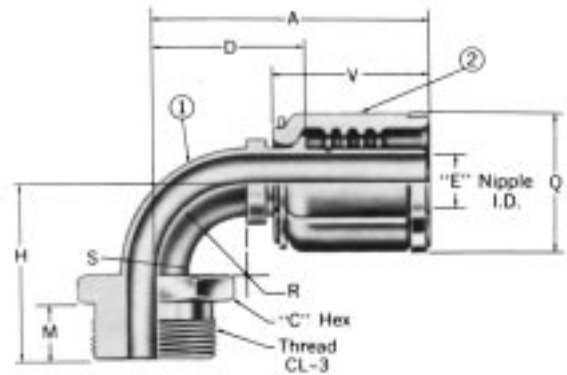

PART NUMBER	I.P.S. SIZE	THREAD A	C	D	E	G	H	M	N	R	S	V	W	WT. EA. (LBS.)
93-191301-1/8-6	1/8	1-14	2.45	1.06	1.55	.24	.81	1.30	.50	.58	.38	1.30	.56	.35
93-191301-1/8-8	1/8	1 1/8-12	3.05	1.25	1.90	.36	.94	1.68	.62	.58	.50	1.65	.75	.57
93-191301-3/16-10	3/16	1 1/8-12	3.57	1.44	2.28	.46	1.12	1.99	.62	.70	1.00	.62	1.80	.83
93-191301-1/2-12	1/2	1 1/4-12	4.15	1.81	2.58	.55	1.25	2.31	.62	.74	1.25	.75	2.10	1.34
93-191301-3/4-16	3/4	2-12	3.93	2.12	2.66	.82	1.44	2.68	.62	.70	1.50	1.00	1.66	2.01
93-191301-1-20	1	2 1/8-12	4.27	2.38	2.91	1.05	1.75	3.17	.75	.70	1.75	1.25	1.75	3.03
93-191301-1 1/4-24	1 1/4	2 1/2-12	4.65	2.88	3.19	1.28	1.94	3.42	.75	.74	2.00	1.50	1.84	3.95
93-191301-1 1/2-32	1 1/2	3 1/8-12	5.68	3.12	3.84	1.75	2.44	4.05	.88	.86	2.50	2.00	2.25	5.42

COMPONENTS DESCRIPTION	REQ'D. PER ASS'Y.	PART NUMBER BASE NO.	PART NUMBER SIZE								MATERIAL	MATERIAL SPECIFICATION
			1/8-6	1/8-8	3/16-10	1/2-12	3/4-16	1-20	1 1/4-24	1 1/2-32		
① Socket	1	1210-	6B	8B	10B	12B					Brass	
① Socket	1	1212-					16B	20B	24B	32B	Brass	
② Nipple Assembly	1	4-186301-	1/8-6	1/8-8	3/16-10	1/2-12	3/4-16	1-20	1 1/4-24	1 1/2-32	see below	see below
Nipple	1	4-921641-	6	8	10	12	16	20	24	32	Monel	QQ-N-281
Elbow	1	4-419037-	6	8	10	12					Monel	MIL-T-1368
Elbow	1	15-419037-					16	20	24	32	Copper Nickel	MIL-T-16420
Adapter	1	4-73461-	1/8-6	1/8-8	3/16-10	1/2-12	3/4-16	1-20	1 1/4-24	1 1/2-32	Monel	QQ-N-281
*Buna-N O-Ring	1	22550	11	114	210	212	214	217	222	224	Buna-N	
*Butyl O-Ring	1	22015-	11	114	210	212	214	217	222	224	Butyl	

All dimensions in inches.

Dimensional information is for reference only.

Variations from these dimensions, on actual parts, may occur as the result of engineering revisions.

\*O-Ring not furnished with this assembly. Must be ordered separately.

# Hose Fittings

## Medium Pressure

### Dogleg 90° 66-190093

for use with Hose 302A, 2580,  
AE369, AE372, FC234

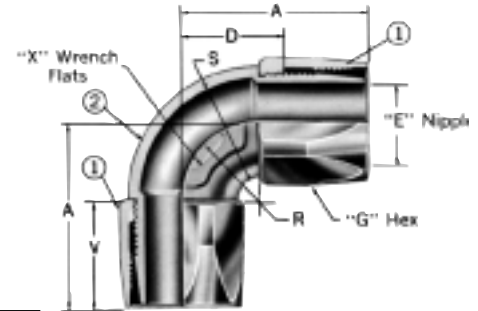

PART NUMBER	A	D	E	G	R	S	V	X	WT. EA. (LBS.)
66-190093-16	2.80	1.53	.75	1.44	1.12	1.25	1.66	1.19	1.16
66-190093-20	2.98	1.62	1.00	1.75	1.22	1.62	1.75	1.44	1.77
66-190093-24	3.24	1.78	1.16	1.94	1.38	1.81	1.84	1.69	2.28
66-190093-32	3.89	2.05	1.69	2.44	1.62	2.44	2.25	2.25	3.22
66-190093-40	4.39	2.48	2.12	3.25	1.88	3.00	2.50	2.75	5.45
66-190093-48	4.70	2.80	2.69	3.88	2.19	3.50	2.50	3.19	10.35

COMPONENTS	REQ'D. PER ASS'Y.	PART NUMBER	SIZE						MATERIAL	MATERIAL SPECIFICATION
			16	20	24	32	40	48		
DESCRIPTION		BASE NO.								
① Socket	2	1212-	16B	20B	24B	32B	40B	48B	Brass	
② Nipple	1	188-185093-	16	20	24	32	40	48	Alum. Bronze	C95800

### Dogleg 90° 412-190093

for use with Hose 302A, 2580,  
AE369, AE372, FC234

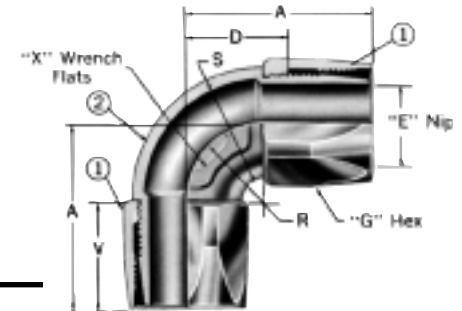

PART NUMBER	A	D	E	G	R	S	V	X	WT. EA. (LBS.)
412-190093-16	2.80	1.53	.75	1.44	1.12	1.15	1.66	1.19	1.18
412-190093-20	2.98	1.62	1.00	1.75	1.22	1.62	1.75	1.44	1.80
412-190093-32	3.89	2.05	1.69	2.50	1.62	2.44	2.25	2.25	3.27
412-190093-40	4.39	2.48	2.12	3.25	1.88	3.00	2.50	2.75	5.53

COMPONENTS	REQ'D. PER ASS'Y.	PART NUMBER	SIZE				MATERIAL	MATERIAL SPECIFICATION
			16	20	32	40		
DESCRIPTION		BASE NO.						
① Socket	2	4-1212-	16	20	32	40	Monel	QQ-N-281
② Nipple	1	407-185093-	16	20	32	40	Stainless Steel	316

All dimensions in inches.

Dimensional information is for reference only. Variations from these dimensions, on actual parts, may occur as the result of engineering revisions.

# Hose Fittings

## Medium Pressure

### Dogleg 90° 375-190093 MIL-F-24787/5 Group VIII, Type D

for use with Hose 302A, 2580, AE369,  
AE370-48, AE372, FC234

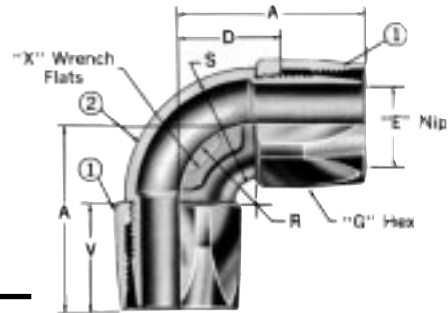

PART NUMBER	A	D	E	G	R	S	V	X	WT. EA. (LBS.)
375-190093-16	2.80	1.53	.75	1.44	1.12	1.25	1.66	1.19	1.17
375-190093-20	2.98	1.62	1.00	1.75	1.22	1.62	1.75	1.44	1.79
375-190093-24	3.24	1.78	1.16	1.94	1.38	1.81	1.84	1.69	2.30
375-190093-32	3.89	2.05	1.69	2.44	1.62	2.44	2.25	2.25	3.25
375-190093-40	4.39	2.48	2.12	3.25	1.88	3.00	2.50	2.75	5.62
375-190093-48	4.70	2.80	2.69	3.88	2.19	3.50	2.50	3.19	10.35

COMPONENTS	REQ'D. PER ASS'Y.	PART NUMBER	SIZE						MATERIAL	MATERIAL SPECIFICATION
			16	20	24	32	40	48		
DESCRIPTION		BASE NO.								
① Socket	2	4-1212-	16	20	24	32	40	48	Monel	QQ-N-281
② Nipple	1	188-185093-	16	20	24	32	40	48	Alum. Bronze	C95800

### Dogleg 90° 4-191302 MIL-F24787/5 Group VIII Type D

for use with Hose 302A, 303, 2580, AE369,  
AE372, FC234

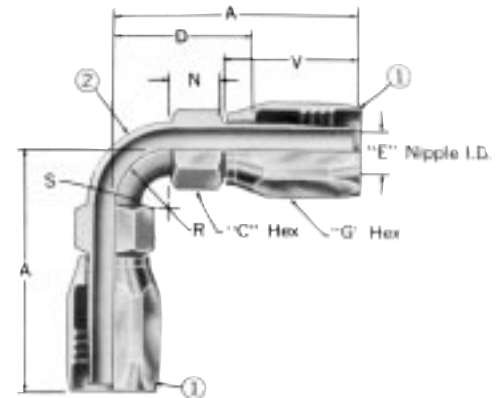

PART NUMBER	A	C	D	E	G	N	R	S	V	WT. EA. (LBS.)
4-191302-6	2.45	.56	1.55	.24	.81	.58	.50	.38	1.30	.24
4-191302-8	3.05	.75	1.90	.36	.94	.58	.75	.50	1.65	.41
4-191302-10	3.57	.81	2.28	.46	1.12	.70	1.00	.62	1.80	.59
4-191302-12	4.15	1.00	2.58	.55	1.25	.74	1.25	.75	2.10	.90
4-191302-16	3.93	1.38	2.66	.82	1.44	.70	1.50	1.00	1.66	1.31

COMPONENTS	REQ'D. PER ASS'Y.	PART NUMBER	SIZE						MATERIAL	MATERIAL SPECIFICATION
			6	8	10	12	16			
DESCRIPTION		BASE NO.								
① Socket	2	4-1210-	6	8	10	12			16	Monel QQ-N-281
① Socket	2	4-1212-							16	Monel QQ-N-281
② Welded Nipple Assembly*	1	4-186302-	6	8	10	12			16	see below see below
Nipple	2	4-921641-	6	8	10	12			16	Monel QQ-N-281
Elbow	1	4-419037-	6	8	10	12				Monel MIL-T-1368
Elbow	1	15-419037-							16	Copper Nickel MIL-T-16420

All dimensions in inches.

\*In accordance with MIL-STD-278.

Dimensional information is for reference only.

Variations from these dimensions, on actual parts, may occur as the result of engineering revisions.

# Hose Fittings

## Medium Pressure

### Dogleg 90° 93-191302

for use with Hose 302A, 303, 2580, AE369,  
AE372, FC234

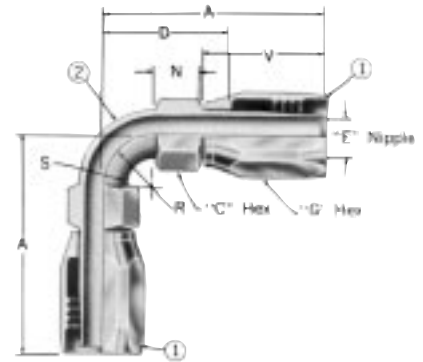

PART NUMBER	A	C	D	E	G	N	R	S	V	WT. EA. (LBS.)
93-191302-6	2.45	.56	1.55	.24	.81	.58	.50	.38	1.30	.23
93-191302-8	3.05	.75	1.90	.36	.94	.58	.75	.50	1.65	.40
93-191302-10	3.57	.81	2.28	.46	1.12	.70	1.00	.62	1.80	.58
93-191302-12	4.15	1.00	2.58	.55	1.25	.74	1.25	.75	2.10	.88
93-191302-16	3.93	1.38	2.66	.82	1.44	.70	1.50	1.00	1.66	1.29

COMPONENTS DESCRIPTION	REQ'D. PER ASS'Y.	PART NUMBER BASE NO.	SIZE					MATERIAL	MATERIAL SPECIFICATION
			6	8	10	12	16		
① Socket	2	1210-	6B	8B	10B	12B		Brass	
① Socket	2	1212-					16B	Brass	
② Welded Nipple Assembly*	1	4-186302-	6	8	10	12	16	see below	see below
Nipple	2	4-921641-	6	8	10	12	16	Monel	QQ-N-281
Elbow	1	4-419037-	6	8	10	12		Monel	MIL-T-1368
Elbow	1	15-419037-					16	Copper Nickel	MIL-T-16420

All dimensions in inches.

\*In accordance with MIL-STD-278.

Variations from these dimensions, on actual parts, may occur as the result of engineering revisions.

# Hose Fittings

## Medium Pressure

### Mates with ANSI B16.5 150 lb. flange 66-190109

for use with Hose 302A, 2580, AE369,  
AE372-48, AE372, FC234

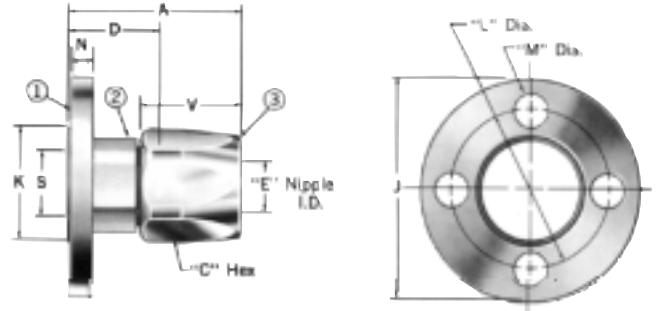

PART NUMBER	I.P.S. SIZE	NUMBER BOLT HOLES	A	C	D	E	J	K	L	M	N	S	V	WT. EA. (LBS.)
66-190109-1/2-16	1/2	4	2.80	1.44	1.53	.82	3.50	1.50	2.38	.62	.38	.71	1.66	1.52
66-190109-3/4-20	3/4	4	2.89	1.75	1.53	1.05	3.88	1.84	2.75	.62	.44	.92	1.75	2.07
66-190109-1-24	1	4	2.92	1.94	1.47	1.28	4.25	2.12	3.12	.62	.44	1.18	1.84	2.45
66-190109-1 1/4-32	1 1/4	4	3.51	2.44	1.66	1.75	4.62	2.74	3.50	.62	.44	1.53	2.25	3.14
66-190109-1 1/2-32	1 1/2	4	3.51	2.44	1.66	1.69	5.00	2.74	3.88	.62	.44	1.77	2.25	3.64
66-190109-2-32	2	4	3.51	2.44	1.66	1.69	6.00	2.74	4.75	.75	.44	1.77	2.25	4.69
66-190109-2-40	2	4	3.89	3.25	1.98	2.21	6.00	3.28	4.75	.75	.44	2.24	2.50	6.21
66-190109-2 1/2-40	2 1/2	4	3.89	3.25	1.98	2.21	7.00	3.28	5.50	.75	.50	2.24	2.50	8.45
66-190109-2 1/2-48	2 1/2	4	3.89	3.88	1.98	2.83	7.00	3.78	5.50	.75	.50	2.71	2.50	8.83

COMPONENTS DESCRIPTION	REQ'D. PER ASS'Y.	PART NUMBER BASE NO.	PART NUMBER SIZE										MATERIAL	MATERIAL SPECIFICATION
			1/2-16	3/4-20	1-24	1 1/4-32	1 1/2-32	2-32	2-40	2 1/2-40	2 1/2-48			
① Swivel Flange	1	188-74021-	1/2-16	3/4-20	1-24	1 1/4-32	1 1/2-32	2-32	2-40	2 1/2-40	2 1/2-48	Alum. Bronze	C95800 or C95400	
② Nipple	1	188-185109-	1/2-16	3/4-20	1-24	1 1/4-32	1 1/2-32	1 1/2-32	2-40	2 1/2-40	2 1/2-48	Alum. Bronze	C95800	
③ Socket	1	1212-	16B	20B	24B	32B	32B	32B	40	40B	48	Brass		

All dimensions in inches.

Dimensional information is for reference only.

Variations from these dimensions, on actual parts, may occur as the result of engineering revisions.

# Hose Fittings

## Medium Pressure

### Mates with ANSI B16.5 150 lb. flange 412-190109

for use with Hose 302A, 2580, AE369,  
AE372, FC234

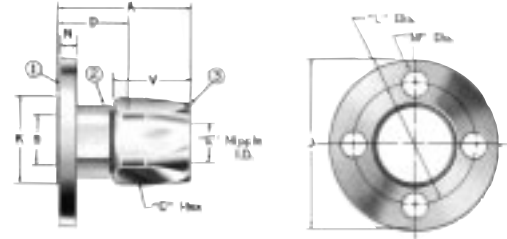

PART NUMBER	I.P.S. SIZE	NUMBER BOLT HOLES	A	C	D	E	J	K	L	M	N	S	V
412-190109-1/2-16	1/2	4	2.80	1.44	1.53	.82	3.50	1.50	2.38	.62	.38	.71	1.68
412-190109-3/4-20	3/4	4	2.89	1.75	1.53	1.05	3.88	1.84	2.75	.62	.44	.92	1.75
412-190109-1-32	1	4	3.51	2.44	1.66	1.75	4.62	2.74	3.50	.62	.44	1.53	2.25
412-190109-1-1/2-32	1 1/2	4	3.51	2.44	1.66	1.69	5.00	2.74	3.88	.62	.44	1.77	2.25
412-190109-2-32	2	4	3.51	2.44	1.66	1.69	6.00	2.74	4.75	.75	.44	1.77	2.25
412-190109-2-40	2	4	3.89	3.25	1.98	2.18	6.00	3.28	4.75	.75	.44	2.24	2.50

COMPONENTS DESCRIPTION	REQ'D. PER ASS'Y.	PART NUMBER BASE NO.	SIZE						MATERIAL	MATERIAL SPECIFICATION
			1/2-16	3/4-20	1-32	1-1/2-32	2-32	2-40		
① Swivel Flange	1	407-74021-	1/2-16	3/4-20	1-32	1-1/2-32	2-32	2-40	Stainless Steel	316
② Nipple	1	407-185109-	1/2-16	3/4-20	1-32	1-1/2-32	1-1/2-32	40	Stainless Steel	316
③ Socket	1	4-1212-	16	20	32	32	32	40	Monel	QQ-N-281

### Mates with ANSI B16.5 150 lb. flange 375-190109 MIL-F-24787/1 Group VIII, Type F, Class V

for use with Hose 302A, 2580, AE369, AE372

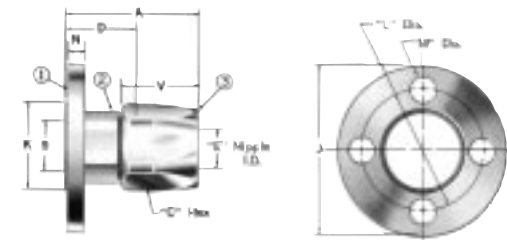

PART NUMBER	I.P.S. SIZE	NUMBER BOLT HOLES	A	C	D	E	J	K	L	M	N	S	V	WT. EA. (LBS.)
375-190109-3/4-20	3/4	4	2.89	1.75	1.53	1.05	3.88	1.84	2.75	.62	.44	.92	1.75	3.22
375-190109-1-24	1	4	2.92	1.94	1.47	1.28	4.25	2.12	3.12	.62	.44	1.18	1.84	2.41
375-190109-1-1/4-32	1 1/4	4	3.51	2.44	1.66	1.75	4.62	2.74	3.50	.62	.44	1.53	2.25	3.28
375-190109-1-1/2-32	1 1/2	4	3.51	2.44	1.66	1.75	5.00	2.74	3.88	.62	.44	1.77	2.25	3.92
375-190109-2-32	2	4	3.51	2.44	1.66	1.75	6.00	2.74	4.75	.75	.44	1.77	2.25	5.38

COMPONENTS DESCRIPTION	REQ'D. PER ASS'Y.	PART NUMBER BASE NO.	SIZE					MATERIAL	MATERIAL SPECIFICATION
			3/4-20	1-24	1-1/4-32	1-1/2-32	2-32		
① Swivel Flange	1	188-74021-	3/4-20	1-24	1-1/4-32	1-1/2-32	2-32	Alum. Bronze	C95800 or C95400
② Nipple	1	188-185109-	3/4-20	1-24	1-1/2-32	1-1/2-32	1-1/2-32	Alum. Bronze	C95800
③ Socket	1	4-1212-	20	24	32	32	32	Monel	QQ-N-281

All dimensions in inches. Dimensional information is for reference only. Variations from these dimensions, on actual parts, may occur as the result of engineering revisions.

# Hose Fittings

## Medium Pressure

### Mates with MIL-F-20042 150 lb. flange 66-190016

for use with Hose 302A, 2580, AE369, AE372, FC234

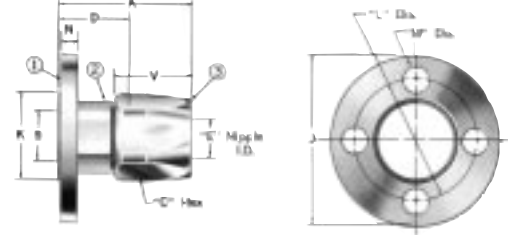

PART NUMBER	I.P.S. SIZE	NUMBER BOLT HOLES	A	C	D	E	J	K	L	M	N	S	V	WT. EA. (LBS.)
66-190016-1/2-16	1/2	3	2.80	1.44	1.53	.82	3.56	1.50	2.44	.56	.38	.71	1.66	1.52
66-190016-3/4-20	3/4	4	2.89	1.75	1.53	1.05	3.81	1.84	2.69	.56	.44	.92	1.75	2.07
66-190016-1-24	1	4	2.92	1.94	1.47	1.28	4.25	2.12	3.12	.56	.44	1.18	1.84	2.45
66-190016-1 1/4-32	1 1/4	4	3.51	2.44	1.66	1.75	4.50	2.74	3.38	.56	.44	1.53	2.25	3.14
66-190016-1 1/2-32	1 1/2	6	3.51	2.44	1.66	1.75	5.06	2.74	3.94	.56	.44	1.77	2.25	3.64
66-190016-2-32	2	6	3.51	2.44	1.66	1.75	5.56	2.74	4.44	.56	.44	1.77	2.25	4.69

COMPONENTS	REQ'D. PER ASS'Y.	PART NUMBER	SIZE				MATERIAL	MATERIAL SPECIFICATION		
			BASE NO.	1/2-16	3/4-20	1-24			1 1/4-32	1 1/2-32
① Swivel Flange	1	188-180005-	1/2-16	3/4-20	1-24	1 1/4-32	1 1/2-32	2-32	Alum. Bronze	C95800 or C95400
② Nipple	1	188-185109-	1/2-16	3/4-20	1-24	1 1/4-32	1 1/2-32	1 1/2-32	Alum. Bronze	C95800
③ Socket	1	1212-	16B	20B	24B	32B	32B	32B	Brass	

### Mates with MIL-F-20042 150 lb. flange 66-190016

for use with Hose AE369, AE370-48, AE372

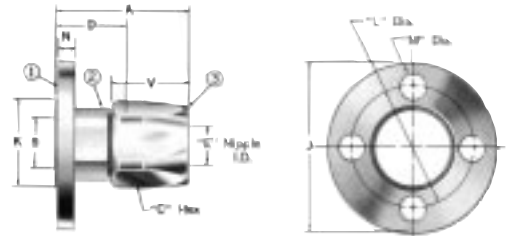

PART NUMBER	I.P.S. SIZE	NUMBER BOLT HOLES	A	C	D	E	J	K	L	M	N	S	V	WT. EA. (LBS.)
66-190016-2-40	2	6	3.89	3.25	1.98	2.21	5.56	3.28	4.44	.56	.44	2.24	2.50	5.75
66-190016-2 1/2-40	2 1/2	6	3.89	3.25	1.98	2.21	6.12	3.28	5.00	.56	.50	2.24	2.50	6.85
66-190016-2 1/2-48	2 1/2	6	3.89	3.88	1.98	2.83	6.12	3.78	5.00	.56	.50	2.71	2.50	7.42
66-190016-3-48	3	8	3.89	3.88	1.98	2.83	6.62	4.50	5.50	.56	.50	3.31	2.50	7.87

COMPONENTS	REQ'D. PER ASS'Y.	PART NUMBER	SIZE				MATERIAL	MATERIAL SPECIFICATION
			BASE NO.	2-40	2 1/2-40	2 1/2-48		
① Swivel Flange	1	188-180005-	2-40	2 1/2-40	2 1/2-48	3-48	Alum. Bronze	C95800 or C95400
② Nipple	1	188-185109-	40	40	2 1/2-48	3-48	Alum. Bronze	C95800
③ Socket	1	1212-	40B	40B	48B	48B	Brass	see (28) page 00

All dimensions in inches.

Dimensional information is for reference only.

Variations from these dimensions, on actual parts, may occur as the result of engineering revisions.

# Hose Fittings

## Medium Pressure

### Mates with ANSI B16.5 150 lb. flange 90° 66-190124

for use with Hose 302A, 2580, AE369, AE372, FC234

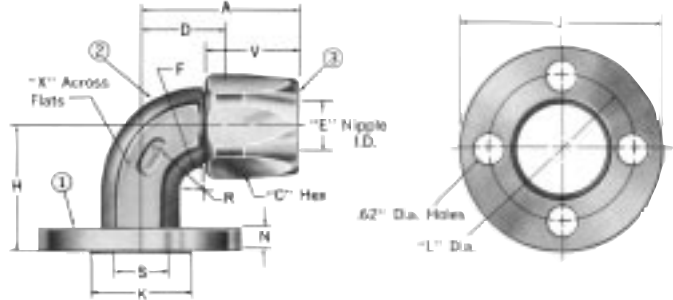

PARTNUMBER	I.P.S. SIZE	NUMBER BOLT HOLES	A	C	D	E	F	H	J	K	L	N	R	S	V	X	WT. EA. (LBS.)
66-190124-1/2-16	1/2	4	2.80	1.44	1.53	.75	1.25	2.38	3.50	1.50	2.38	.38	1.12	.71	1.66	1.19	1.77
66-190124-3/4-20	3/4	4	2.98	1.75	1.62	1.00	1.62	2.56	3.88	1.84	2.75	.44	1.22	.92	1.75	1.44	3.62
66-190124-1-24	1	4	3.24	1.94	1.78	1.16	1.81	2.75	4.25	2.12	3.12	.44	1.38	1.18	1.84	1.69	3.19
66-190124-1 1/4-32	1 1/4	4	3.89	2.44	2.05	1.69	2.44	3.06	4.62	2.74	3.50	.44	1.62	1.53	2.25	2.25	4.38
66-190124-1 1/2-32	1 1/2	4	3.89	2.44	2.05	1.69	2.44	3.06	5.00	2.74	3.88	.44	1.62	1.77	2.25	2.25	5.02

COMPONENTS DESCRIPTION	REQ'D. PER ASS'Y.	PART NUMBER BASE NO.	SIZE					MATERIAL	MATERIAL SPECIFICATION
			1/2-16	3/4-20	1-24	1 1/4-32	1 1/2-32		
① Swivel Flange	1	188-74021-	1/2-16	3/4-20	1-24	1 1/4-32	1 1/2-32	Alum. Bronze	C95800 or C95400
② Nipple	1	188-185029-	1/2-16	3/4-20	1-24	1 1/4-32	1 1/2-32	Alum. Bronze	C95800
③ Socket	1	1212-	16B	20B	24B	32B	32B	Brass	

All dimensions in inches.

Dimensional information is for reference only.

Variations from these dimensions, on actual parts, may occur as the result of engineering revisions.

# Hose Fittings

## Medium Pressure

### Mates with ANSI B16.5 150 lb. flange 90° 66-190124

for use with Hose 302A, 2580, AE369, AE370-48, AE372

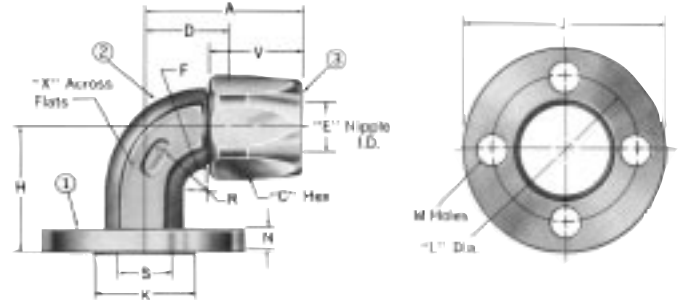

PART NUMBER	I.P.S. SIZE	NUMBER BOLT HOLES	A	C	D	E	F	H	J	K	L	N	R	S	V	X	WT. EA. (LBS.)
66-190124-2-32	2	4	3.89	2.44	2.05	1.69	2.44	3.06	6.00	2.74	4.75	.44	1.62	1.77	2.25	2.25	5.92
66-190124-2-40	2	4	4.39	3.25	2.48	2.12	3.00	3.50	6.00	3.28	4.75	.44	1.88	2.24	2.50	2.75	8.18
66-190124-2½-40	2½	4	4.39	3.25	2.48	2.12	3.00	3.50	7.00	3.28	5.50	.50	1.88	2.24	2.50	2.75	9.74
66-190124-2½-48	2½	4	4.61	3.88	2.70	2.69	3.50	4.00	7.00	3.78	5.50	.50	2.09	2.71	2.50	3.19	12.54
66-190124-3-48	3	4	4.61	3.88	2.70	2.69	3.50	4.00	7.50	4.50	6.00	.50	2.09	3.31	2.50	3.19	13.49

COMPONENTS DESCRIPTION	REQ'D. PER ASS'Y.	PART NUMBER BASE NO.	SIZE					MATERIAL	MATERIAL SPECIFICATION
			2-32	2-40	2½-40	2½-48	3-48		
① Swivel Flange	1	188-74021-	2-32	2-40	2½-40	2½-48	3-48	Alum. Bronze	C95800 or C95400
② Nipple	1	188-185029-	1½-32	40	40	2½-48	3-48	Alum. Bronze	C95800
③ Socket	1	1212-	32B	40B	40B	48B	48B	Brass	

All dimensions in inches.

Dimensional information is for reference only.

Variations from these dimensions, on actual parts, may occur as the result of engineering revisions.

# Hose Fittings

## Medium Pressure

### Mates with ANSI B16.5 150 lb. flange 90° 412-190124

for use with Hose 302A, 2580, AE369, AE372

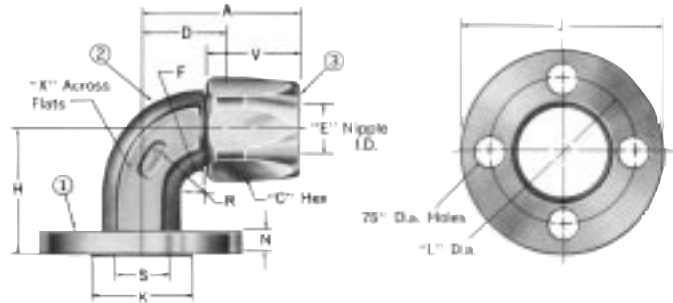

PART NUMBER	I.P.S. SIZE	NUMBER BOLT HOLES	A	C	D	E	H	J	K	L	M	N	R	S	F	V	X	WT. EA. (LBS.)
412-190124-1¼-32	1¼	4	3.89	2.44	2.05	1.69	3.06	4.62	2.74	4.44	.62	.44	1.62	1.53	2.44	2.25	2.25	4.44
412-190124-1½-32	1½	4	3.89	2.44	2.05	1.69	3.06	5.00	2.74	5.09	.62	.44	1.62	1.77	2.44	2.25	2.25	5.09
412-190124-2-32	2	4	3.89	2.44	2.05	1.69	3.06	6.00	2.74	6.01	.62	.44	1.62	1.77	2.44	2.25	2.25	6.01

COMPONENTS	REQ'D. PER ASS'Y.	PART NUMBER	SIZE			MATERIAL	MATERIAL SPECIFICATION	
			BASE NO.	1¼-32	1½-32			2-32
① Swivel Flange	1	407-74021-		1¼-32	1½-32	2-32	Stainless Steel	316
② Nipple	1	407-185029-		1¼-32	1½-32	1½-32	Stainless Steel	316
③ Socket	1	4-1212-		32	32	32	Monel	QQ-N-281

All dimensions in inches.

Dimensional information is for reference only.

Variations from these dimensions, on actual parts, may occur as the result of engineering revisions.

# Hose Fittings

## Medium Pressure

**Mates with ANSI B16.5 150 lb. flange 90°  
375-190124**

**MIL-F-24787/1, Group VIII, Type FL, Class V**

for use with Hose 302A, 2580, AE369, AE372, FC234

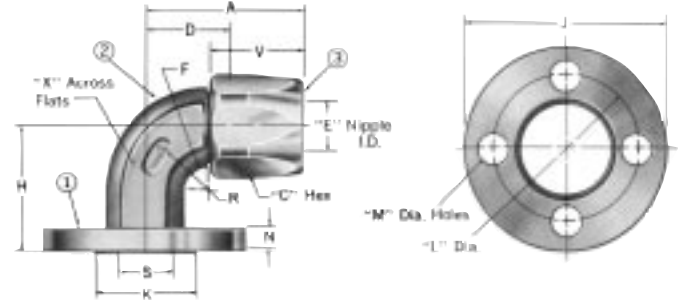

PART NUMBER	I.P.S. SIZE	NUMBER BOLT HOLES	A	C	D	E	F	H	J	K	L	M	N	R	S	V	X	WT. EA. (LBS.)
375-190124-1/2-16	1/2	4	2.80	1.44	1.53	.75	1.25	2.38	3.50	1.50	2.38	.62	.38	1.12	.71	1.66	1.19	1.77
375-190124-3/4-20	3/4	4	2.98	1.75	1.62	1.00	1.62	2.56	3.88	1.84	2.75	.62	.44	1.22	.92	1.75	1.44	3.63
375-190124-1-24	1	4	3.24	1.94	1.78	1.16	1.81	2.75	4.25	2.12	3.12	.62	.44	1.38	1.18	1.84	1.69	3.22
375-190124-1 1/4-32	1 1/4	4	3.89	2.44	2.05	1.69	2.44	3.06	4.62	2.74	3.50	.62	.44	1.62	1.53	2.25	2.25	4.50
375-190124-1 1/2-32	1 1/2	4	3.89	2.44	2.05	1.69	2.44	3.06	5.00	2.74	3.88	.62	.44	1.62	1.77	2.25	2.25	5.15
375-190124-2-32	2	4	3.89	2.44	2.05	1.69	2.44	3.06	6.00	2.74	4.75	.75	.44	1.62	1.77	2.25	2.25	

COMPONENTS DESCRIPTION	REQ'D. PER ASS'Y.	PART NUMBER BASE NO.	SIZE						MATERIAL	MATERIAL SPECIFICATION
			1/2-16	3/4-20	1-24	1 1/4-32	1 1/2-32	2-32		
① Swivel Flange	1	188-74021-	1/2-16	3/4-20	1-24	1 1/4-32	1 1/2-32	2-32	Alum. Bronze	C95800 or C95400
② Nipple	1	188-185029-	1/2-16	3/4-20	1-24	1 1/4-32	1 1/2-32	1 1/2-32	Alum. Bronze	C95800
③ Socket	1	4-1212-	16	20	24	32	32	32	Monel	QQ-N-281

All dimensions in inches.

Dimensional information is for reference only.

Variations from these dimensions, on actual parts, may occur as the result of engineering revisions.

# Hose Fittings

## Medium Pressure

### Mates with MIL-F-20042 150 lb. flange 90° 66-190103

for use with Hose 302A, 2580, AE369, AE372, FC234

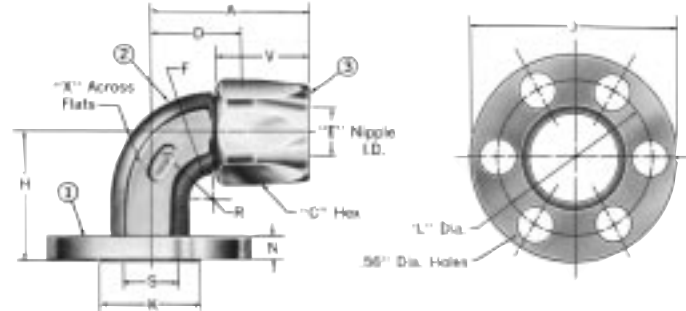

PART NUMBER	I.P.S. SIZE	NUMBER BOLT HOLES	DIMENSIONS (INCHES)													
			A	C	D	E	F	H	J	K	L	N	T	S	V	X
66-190103-1/2-16	1/2	3	2.80	1.44	1.53	.75	1.25	2.38	3.56	1.50	2.44	.38	1.12	.71	1.66	1.19
66-190103-3/4-16	3/4	4	2.80	1.44	1.53	.75	1.25	2.38	3.81	1.50	2.69	.44	1.12	.71	1.66	1.19
66-190103-3/4-20	3/4	4	2.98	1.75	1.62	1.00	1.62	2.56	3.81	1.84	2.69	.44	1.22	.92	1.75	1.44
66-190103-1-16	1	4	2.80	1.44	1.53	.75	1.25	2.38	4.25	1.50	3.12	.44	1.12	.71	1.66	1.19
66-190103-1-24	1	4	3.24	1.94	1.78	1.16	1.81	2.75	4.25	2.12	3.12	.44	1.38	1.18	1.84	1.69
66-190103-1 1/4-32	1 1/4	4	3.89	2.44	2.05	1.69	2.44	3.06	4.50	2.74	3.38	.44	1.62	1.53	2.25	2.25
66-190103-1 1/2-32	1 1/2	6	3.89	2.44	2.05	1.69	2.44	3.06	5.06	2.74	3.94	.44	1.62	1.77	2.25	2.25
66-190103-2-32	2	6	3.89	2.44	2.05	1.59	2.44	3.06	5.56	2.74	4.44	.44	1.62	1.75	2.25	2.25

COMPONENTS DESCRIPTION	REQ'D. PER ASS'Y.	PART NUMBER BASE NO.	SIZE									MATERIAL	MATERIAL SPECIFICATION
			1/2-16	3/4-16	3/4-20	1-16	1-24	1 1/4-32	1 1/2-32	2-32			
① Swivel Flange	1	188-180005-	1/2-16	3/4-16	3/4-20	1-16	1-24	1 1/4-32	1 1/2-32	2-32	Aluminum Bronze	C95800 or C95400	
② Nipple	1	188-185029-	1/2-16	1/2-16	3/4-20	1/2-16	1-24	1 1/4-32	1 1/2-32	1 1/2-32	Aluminum Bronze	C95800	
③ Socket	1	1212-	16B	16B	20B	16B	24B	32B	32B	32B	Brass		

All dimensions in inches.

Dimensional information is for reference only.

Variations from these dimensions, on actual parts, may occur as the result of engineering revisions.

# Hose Fittings

## Medium Pressure

### Mates with MIL-F-20042 150 lb. flange 90° 66-190103

for use with Hose AE369, AE370-48, AE372

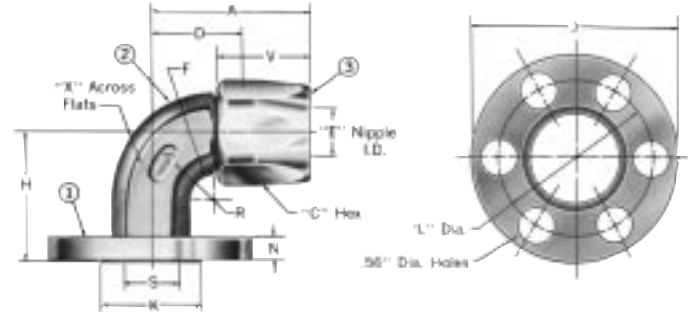

PART NUMBER	I.P.S. SIZE	NUMBER BOLT HOLES	DIMENSIONS (INCHES)													
			A	C	D	E	F	H	J	K	L	N	R	S	V	X
66-190103-2-40	2	6	4.39	3.25	2.48	2.12	3.00	3.50	5.56	3.28	4.44	.44	1.88	2.24	2.50	2.75
66-190103-2½-40	2½	6	4.39	3.25	2.48	2.12	3.00	3.50	6.12	3.28	5.00	.50	1.88	2.24	2.50	2.75
66-190103-2½-48	2½	6	4.61	3.88	2.70	2.69	3.50	4.00	6.12	3.78	5.00	.50	2.09	2.71	2.50	3.19
66-190103-3-48	3	8	4.61	3.88	2.70	2.69	3.50	4.00	6.62	4.50	5.50	.50	2.09	3.31	2.50	3.19

COMPONENTS	REQ'D. PER ASS'Y.	PART NUMBER	SIZE				MATERIAL	MATERIAL SPECIFICATION
			2-40	2½-40	2½-48	3-48		
DESCRIPTION		BASE NO.						
① Swivel Flange	1	188-180005-	2-40	2½-40	2½-48	3-48	Aluminum Bronze	C95800 or C95400
② Nipple	1	188-185029-	40	40	2½-48	3-48	Aluminum Bronze	C95800
③ Socket	1	1212-	40B	40B	48B	48B	Brass	

All dimensions in inches.

Dimensional information is for reference only.

Variations from these dimensions, on actual parts, may occur as the result of engineering revisions.

# Hose Fittings

## Medium Pressure

### Male Sil-Brze split clamp (for ultrasonic testing) FC9423-375\*

for use with Hose 302A, 2580, AE369, AE370-48, AE372

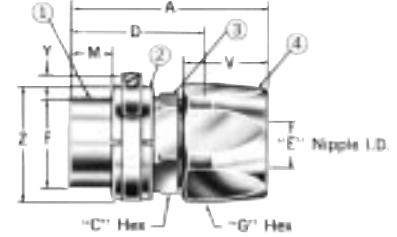

PART NUMBER	I.P.S. SIZE	A	C	D	E	F	G	M	V	Y	Z
FC9423-2032-375*	1¼	5.44	2.12	3.60	1.53	1.66	2.44	1.12	2.25	.39	3.00
FC9423-2432-375*	1½	5.53	2.12	3.69	1.75	1.90	2.44	1.25	2.25	.39	3.31
FC9423-3240-375*	2	5.97	2.62	4.07	2.21	2.38	3.25	1.31	2.50	.39	4.00
FC9423-4048-375*	2½	5.94	3.25	4.04	2.73	2.88	3.88	1.12	2.50	.39	4.42

COMPONENTS	REQ'D. PER ASS'Y.	PART NUMBER	PART NUMBER				MATERIAL	MATERIAL SPECIFICATION
			BASE NO.	2032	2432	3240		
① Tailpiece Assembly	1	FF5002-Size-188	20	24	32	40	Alum. Bronze	C95800 or C95400
② Clamp	1	900758-	1¼	1½	2	2½		see page

### Female split clamp (Female Sil-Brze tailpiece suitable for ultrasonic testing) FC9424-375

#### MIL-F-24787/4, Group VIII, Type E

for use with Hose 302A, 2580, AE369, AE370-48, AE372

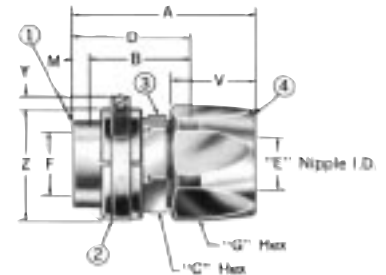

PART NUMBER	I.P.S. SIZE	A	B	C	D	E	F	G	M	V	Y	Z
FC9424-2032-375	1¼	4.98	2.63	2.12	3.13	1.53	1.66	2.44	.50	2.25	.39	3.00
FC9424-2432-375	1½	5.03	2.57	2.12	3.19	1.69	1.90	2.44	.62	2.25	.39	3.31
FC9424-3240-375	2	5.44	2.88	2.62	3.54	2.18	2.38	3.25	.66	2.50	.39	4.00
FC9424-4048-375	2½	5.76	3.07	3.25	3.85	2.73	2.88	3.88	.78	2.50	.39	4.42

COMPONENTS	REQ'D. PER ASS'Y.	PART NUMBER	PART NUMBER				MATERIAL	MATERIAL SPECIFICATION
			BASE NO.	2032	2432	3240		
① Tailpiece Assembly	1	FF5001-188	20	24	32	40	Alum. Bronze	C95800 or C95400
② Clamp Assembly	1	900758-	1¼	1½	2	2½		see page 125
③ Nipple	1	188-1237-	1¼-32	1½-32	2-40	2½-48	Alum. Bronze	C95800
④ Socket	1	4-1212-	32	32	40	48	Monel	QQN-281

# Hose Fittings

## Medium Pressure

### Male split clamp (Sil-Braze tailpiece suitable for ultrasonic testing) 90° FC9425-375

MIL-F-24787/4, Group VIII, Type EL\*

for use with Hose 302A, 2580, AE369, AE370-48, AE372

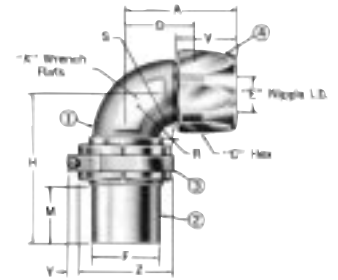

PART NUMBER	I.P.S. SIZE	A	C	D	E	F	H	M	R	S	V	X	Y	Z
FC9425-2032-375	1/4	3.89	2.44	2.05	1.69	1.66	4.18	1.12	1.62	2.44	2.25	2.25	.39	3.00
FC9425-2432-375	1/2	3.89	2.44	2.05	1.69	1.90	4.30	1.25	1.62	2.44	2.25	2.25	.39	3.31
FC9425-3240-375	2	4.39	3.25	2.48	2.12	2.38	4.76	1.31	1.88	3.00	2.50	2.75	.39	4.00
FC9425-4048-375	2 1/2	4.61	3.88	2.70	2.69	2.88	4.71	1.12	2.09	3.50	2.50	3.19	.39	4.42

DESCRIPTION	REQ'D. PER ASS'Y.	PART NUMBER BASE NO.	PART NUMBER SIZE				MATERIAL	MATERIAL SPECIFICATION
			2032	2432	3240	4048		
① Nipple	1	188-185249-	1/4-32	1/2-32	2-40	2 1/2-48	Alum. Bronze	C95800
② Tailpiece Assembly	1	FF5002-size-188	20-	24-	32-	40-	Bronze	C95800 or C95400
③ Clamp Assembly	1	900758-	1/4	1/2	2	2 1/2		see page 125
④ Socket	1	4-1212-	32	32	40	48	Monel	QQN-281

### Female Sil-Braze split clamp (for ultrasonic testing) 90° FC9426-375

for use with Hose 302A, 2580, AE369, AE370-48, AE372

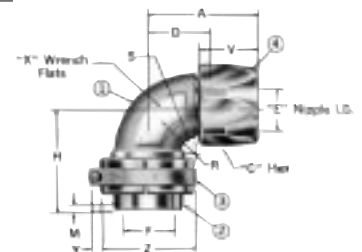

PART NUMBER	I.P.S. SIZE	A	C	D	E	F	H	M	R	S	V	X	Y	Z
FC9426-2032-375	1/4	3.89	2.44	2.05	1.69	1.66	3.71	.50	1.62	2.44	2.25	2.25	.39	3.00
FC9426-2432-375	1/2	3.89	2.44	2.05	1.69	1.90	3.80	.62	1.62	2.44	2.25	2.25	.39	3.31
FC9426-3240-375	2	4.39	3.25	2.48	2.12	2.38	4.23	.66	1.88	3.00	2.50	2.75	.39	4.00
FC9426-4048-375	2 1/2	4.61	3.88	2.70	2.69	2.88	4.52	.78	2.09	3.50	2.50	3.19	.39	4.42

DESCRIPTION	REQ'D. PER ASS'Y.	PART NUMBER BASE NO.	PART NUMBER SIZE				MATERIAL	MATERIAL SPECIFICATION
			2032	2432	3240	4048		
① Nipple	1	188-185249-	1/4-32	1/2-32	2-40	2 1/2-48	Alum. Bronze	C95800
② Tailpiece Assembly	1	FF5001-Size-188	20	24	32	40	Alum. Bronze	C95800 or C95400
③ Clamp Assembly	1	900758-	1/4	1/2	2	2 1/2	Bronze	see page 125
④ Socket	1	4-1212-	32	32	40	48	Monel	QQN-281

All dimensions in inches.

Dimensional information is for reference only.

Variations from these dimensions, on actual parts, may occur as the result of engineering revisions.

\*Optional Material – 66

# Hose Fittings

## High Pressure

### Male pipe

#### 4-4722

for use with Hose 2766, AE371, AE373, FC163

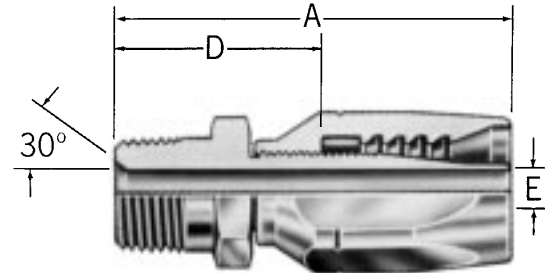

PART NUMBER	HOSE ID	THREAD	A	D	E	WT. EA. (LBS.)
4-4722-4-4	¼	¼-18	2.50	1.27	.17	.26
4-4722-6-6	⅜	⅜-18	2.75	1.28	.31	.36
4-4722-8-8	½	½-14	3.09	1.58	.39	.57
4-4722-8-10	⅝	½-14	3.18	1.62	.48	.57
4-4722-12-12	¾	¾-14	3.61	1.74	.61	1.08
4-4722-16-16	1	1-11½	4.90	2.35	.82	1.79
4-4722-20-20	1¼	1¼-11½	4.90	2.58	1.05	2.74
4-4722-24-24	1½	1½-11½	4.98	2.74	1.28	3.31
4-4722-32-32	2	2-11½	5.50	3.06	1.75	5.21

COMPONENTS	REQ'D. PER ASS'Y.	PART NUMBER										MATERIAL	MATERIAL SPECIFICATION
		SIZE											
DESCRIPTION		BASE NO.	4-4	6-6	8-8	8-10	12-12	16-16	20-20	24-24	32-32		
① Nipple	1	4-4202-	4-4	6-6	8-8	8-10	12-12	16-16	20-20	24-24		Monel	QQ-N-281
① Nipple	1	4-4202-									32-32	Monel	QQ-N-281 or QQ-N-286
② Socket	1	4-4010-	4	6	8	10	12		20	24	32	Monel	QQ-N-281
② Socket	1	4-4013-						16				Monel	QQ-N-281

All dimensions in inches.

Dimensional information is for reference only.

Variations from these dimensions, on actual parts, may occur as the result of engineering revisions.

# Hose Fittings

## High Pressure

### SAE 37° flare swivel (JIC)

#### 4-4721

#### MIL-F-24787/2, Group I, Type A

for use with Hose 2766, AE371, AE373, FC163

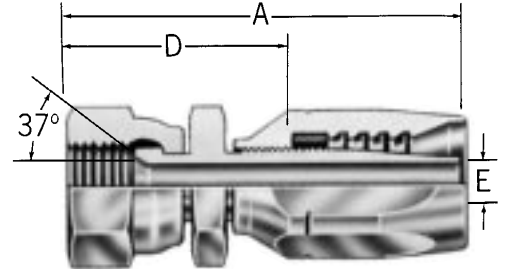

PART NUMBER	HOSE ID	THREAD	A	D	E	WT. EA. (LBS.)
4-4721-4-4	¼	⅞-20	2.64	1.41	.17	.24
4-4721-5-4	¼	½-20	2.72	1.49	.17	.26
4-4721-6-4	¼	⅜-18	2.79	1.56	.17	.28
4-4721-6-6	⅜	⅜-18	2.98	1.51	.31	.37
4-4721-8-6	⅜	¾-16	3.11	1.64	.31	.44
4-4721-8-8	½	¾-16	3.20	1.68	.39	.68
4-4721-10-8	½	⅞-14	3.31	1.80	.39	.59
4-4721-10	⅝	⅞-14	3.40	1.85	.50	.61
4-4721-12	¾	1⅛-12	3.86	1.99	.61	1.12
4-4721-16	1	1⅛-12	4.48	2.43	.82	1.91
4-4721-20	1¼	1⅝-12	5.10	2.78	1.05	3.38
4-4721-24	1½	1⅝-12	5.16	2.92	1.28	4.10
4-4721-32	2	2½-12	5.90	3.46	1.75	6.27

COMPONENTS DESCRIPTION	REQ'D. PER ASS'Y.	PART NUMBER BASE NO.	PART NUMBER SIZE												MATERIAL	MATERIAL SPECIFICATION	
			4-4	5-4	6-4	6-6	8-6	8-8	10-8	10	12	16	20	24			32
① Socket	1	4-4010-	4	4	4	6	6	8	8	10	12		20	24	32	Monel	QQ-N-281
① Socket	1	4-4013-											16			Monel	QQ-N-281
② Nipple Assembly	1	4-4103-4-	4-4	5-4	6-4	6-6	8-6	8-8	10-8	10	16	16	20	24	32	Monel	see below
Nipple	1	4-4103-											16	20		Monel	QQ-N-281
Nipple	1	4-4103-												24	32	Monel	QQ-N-286
Nut	1	4-210204-	4	5	6	6	8	8	10	10	12	16	20	24	32	Monel	QQ-N-281

All dimensions in inches.

Dimensional information is for reference only.

Variations from these dimensions, on actual parts, may occur as the result of engineering revisions.

# Hose Fittings

## High Pressure

### Male O-Ring seal union (C.P.V.)

#### 4-190909

#### MIL-F-24787/3, Group I, Type C

for use with Hose 2766, AE371, AE373, FC163

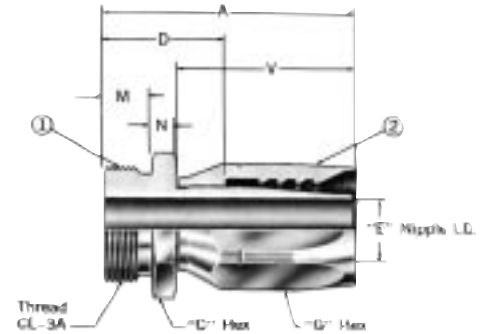

PART NUMBER*	I.P.S. SIZE	THREAD	A	C	D	E	G	M	N	V	WT. EA. (LBS.)
4-190909-1/8-4	1/8	1-14	2.50	1.06	1.26	.17	.81	.50	.25	1.73	.38
4-190909-1/4-6	1/4	1 1/16-12	2.82	1.25	1.34	.31	1.00	.62	.25	1.92	.59
4-190909-3/8-8	3/8	1 3/8-12	2.96	1.44	1.45	.39	1.12	.62	.31	2.01	.86
4-190909-1/2-12	1/2	1 3/4-12	3.49	1.81	1.62	.50	1.50	.62	.38	2.47	1.56
4-190909-3/4-16	3/4	2-12	4.09	2.12	2.04	.62	1.81	.62	.50	2.95	2.34
4-190909-1-16	1	2 5/16-12	4.34	2.38	2.28	.82	1.81	.75	.62	2.95	2.81
4-190909-1-20	1	2 5/16-12	4.80	2.38	2.48	.81	2.25	.75	.62	3.42	4.03
4-190909-1 1/4-24	1 1/4	2 3/4-12	4.72	2.88	2.48	1.21	2.50	.75	.62	3.34	5.50
4-190909-1 1/2-32	1 1/2	3 1/16-12	5.34	3.12	2.90	1.39	3.00	.88	.75	3.70	7.38
4-190909-2-32	2	3 3/4-12	5.34	3.88	2.90	1.75	3.00	.88	.75	3.70	9.64

COMPONENTS	REQ'D. PER ASS'Y.	PART NUMBER	PART NUMBER SIZE											MATERIAL	MATERIAL SPECIFICATION
			BASE NO.	1/4-4	1/4-6	3/8-8	1/2-12	3/4-16	1-16	1-20	1 1/4-24	1 1/2-32	2-32		
① Nipple	1	4-220643-	1/4-4	1/4-6	3/8-8	1/2-12	3/4-16	1-16	1-20	1 1/4-24	1 1/2-32	2-32	Monel	QQ-N-281 or QQN-286	
② Socket	1	4-4010-	4	6	8	12			20	24	32	32	Monel	QQ-N-281	
② Socket	1	4-4013-					16	16					Monel	QQ-N-281	
** Buna-N O-Ring	1	22550-	11	114	210	212	214	217	217	222	224	227	Buna-N		
** Butyl O-Ring	1	22015-	11	114	210	212	214	217	217	222	224	227	Butyl		

All dimensions in inches.

Dimensional information is for reference only.

Variations from these dimensions, on actual parts, may occur as the result of engineering revisions.

\*O-Ring not furnished with this assembly. Must be ordered separately.

# Hose Fittings

## High Pressure

### Male O-Ring seal union (C.P.V.) 90° 4-191304

#### MIL-F-24787/3, Group I, Type CL

for use with Hose 2766, AE371,  
AE373, FC163

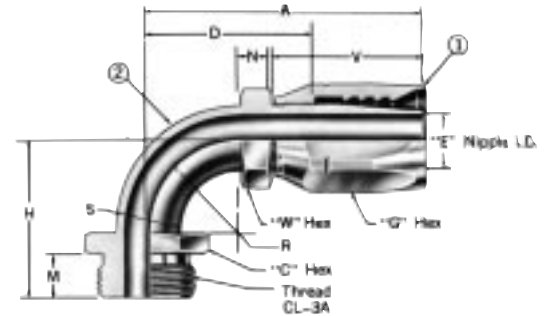

PART NUMBER	I.P.S. SIZE	THREAD	A	C	D	E	G	H	M	N	R	S	V	W	WT. EA. (LBS.)
4-191304-¼-6	¼	1⅞-12	3.11	1.25	1.63	.31	1.00	1.43	.62	.62	.50	.38	1.92	.69	.62
4-191304-⅜-8	⅜	1⅞-12	3.44	1.44	1.93	.39	1.12	1.74	.62	.62	.75	.50	2.01	.81	.92
4-191304-½-12	½	1⅞-12	4.52	1.81	2.65	.61	1.50	2.31	.62	.74	1.25	.75	2.47	1.06	1.71
4-191304-¾-16	¾	2-12	5.25	2.12	3.20	.82	1.81	2.68	.62	.74	1.50	1.00	2.95	1.38	2.87
4-191304-1-16	1	2⅝-12	5.25	2.38	3.20	.82	1.81	2.92	.75	.74	1.50	1.00	2.95	1.38	3.44
4-191304-1-20	1	2⅝-12	6.10	2.38	3.78	1.05	2.25	3.17	.75	.86	1.75	1.25	3.42	1.62	5.03
4-191304-1¼-20	1¼	2¾-12	6.10	2.88	3.78	1.05	2.25	3.17	.75	.86	1.75	1.25	3.42	1.62	5.03
4-191304-1¼-24	1¼	2¾-12	6.32	2.88	4.09	1.28	2.50	3.42	.75	.92	2.00	1.50	3.34	1.88	6.02
4-191304-1½-32	1½	3⅞-12	7.38	3.12	4.94	1.75	3.00	4.05	.88	1.12	2.50	2.00	3.70	2.50	8.49
4-191304-2-32	2	3¾-12	7.38	3.88	4.94	1.75	3.00	.88	1.12	2.50	2.00	3.70	2.50	4.05	10.64

COMPONENTS	REQ'D. PER ASS'Y.	PART NUMBER	SIZE											MATERIAL	MATERIAL SPECIFICATION
			BASE NO.	¼-6	⅜-8	½-12	¾-16	1-16	1-20	1¼-20	1¼-24	1½-32	2-32		
DESCRIPTION															
① Socket	1	4-4010-	6	8	12			20	20	24	32	32	Monel	QQ-N-281	
① Socket	1	4-4013-				16	16						Monel	QQ-N-281	
② Welded Nipple Assembly*	1	4-186304-	¼-6	⅜-8	½-12	¾-16	1-16	1-20	1¼-20	1¼-24	1½-32	2-32	see below	see below	
Nipple	1	4-461641-	6	8	12	16	16	20	20	24			Monel	QQ-N-281	
Nipple	1	4-461641-									32	32	Monel	QQ-N-281 or QQ-N-286	
Elbow	1	4-419037	6	8	12								Monel	MIL-T-1368	
Elbow	1	15-419037-				16	16	20	20	24	32	32	Copper Nickel	MIL-T-16420	
Adapter	1	4-73461-	¼-6	⅜-8	½-12	¾-16	1-16	1-20	1¼-20	1¼-24	1½-32	2-32	Monel	QQ-N-281	
** Buna-N O-Ring	1	22550-	114	210	212	214	217	217	222	222	224	227	Buna-N		
** Butyl O-Ring	1	22015-	114	210	212	214	217	217	222	222	224	227	Butyl		

All dimensions in inches.

\*In accordance with MIL-STD-278.

Dimensional information is for reference only.

Variations from these dimensions, on actual parts, may occur as the result of engineering revisions.

\*O-Ring not furnished with this assembly. Must be ordered separately.

# Hose Fittings

## High Pressure

### Dogleg 90°

### 4-191305

### MIL-F-24787/5, Group I, Type D

for use with Hose FC163, AE373, AE371, 2766

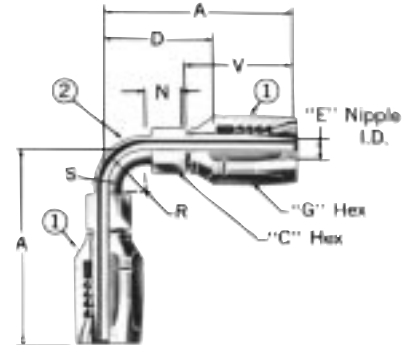

PART NUMBER	A	C	D	E	G	N	R	S	V	WT. EA. (LBS.)
4-191305-6	3.11	.69	1.63	.31	1.00	.62	.50	.38	1.92	.76
4-191305-8	3.44	.81	1.93	.39	1.12	.62	.75	.50	2.01	1.12
4-191305-12	4.52	1.06	2.65	.61	1.50	.74	1.25	.75	2.47	2.03
4-191305-16	5.25	1.38	3.20	.82	1.81	.74	1.50	1.00	2.95	3.77
4-191305-20	6.09	1.62	3.78	1.05	2.25	.86	1.75	1.25	3.42	6.31
4-191305-24	6.32	1.88	4.09	1.28	2.50	.92	2.00	1.50	3.34	7.85
4-191305-32	7.38	2.50	4.94	1.75	3.00	1.12	2.50	2.00	3.70	11.43

COMPONENTS	REQ'D. PER ASS'Y.	PART NUMBER	SIZE							MATERIAL	MATERIAL SPECIFICATION		
			BASE NO.	6	8	12	16	20	24			32	
① Socket	2	4-4010-		6	8	12			20	24	32	Monel	QQ-N-281
① Socket	2	4-4013-						16				Monel	QQ-N-281
② Welded Nipple Assembly*	1	4-186305-		6	8	12	16	20	24	32		see below	see below
Nipple	2	4-461641-		6	8	12	16	20	24			Monel	QQ-N-281
Nipple	2	4-461641-								32		Monel	QQ-N-281 or QQ-N-286
Elbow	1	4-419037-		6	8	12						Monel	MIL-T-1368
Elbow	1	15-419037-					16	20	24	32		Copper Nickel	MIL-T-16420

All dimensions in inches.

\*In accordance with MIL-STD-278.

Dimensional information is for reference only.

Variations from these dimensions, on actual parts, may occur as the result of engineering revisions.

# Hose Fittings

## High Pressure

**Mates with MIL-F-20042 150/400 lb. flange  
FC9506-463**

**MIL-F-24787/1, Group I, Type F, Class II**

for use with Hose 2766, AE371, AE373, FC163

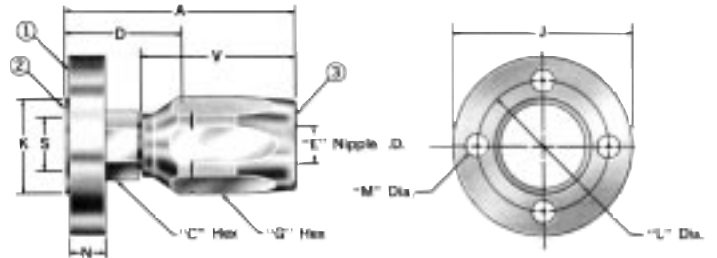

PART NUMBER	I.P.S. SIZE	NUMBER BOLT HOLES	A	C	D	E	G	J	K	L	M	N	S	V	WT. EA. (LBS.)
FC9056-0812-463	½	3	3.92	1.12	2.05	.61	1.50	3.56	1.50	2.44	.56	.70	.71	2.47	2.78
FC9056-1216-463	¾	4	4.34	1.38	2.29	.82	1.81	3.81	1.84	2.69	.56	.70	.92	2.95	3.61
FC9056-1620-463	1	4	4.81	1.62	2.49	1.05	2.25	4.25	2.12	3.12	.56	.77	1.18	3.42	5.55
FC9056-2024-463	1¼	4	4.97	2.12	2.73	1.28	2.50	4.50	2.74	3.38	.56	.83	1.53	3.34	6.75
FC9056-2432-463	1½	6	5.33	2.25	2.89	1.75	3.00	5.06	2.74	3.94	.56	.83	1.77	3.70	8.64
FC9056-3232-463	2	6	5.33	2.69	2.89	1.75	3.00	5.56	3.28	4.44	.56	.83	2.24	3.70	10.56

COMPONENTS	REQ'D. PER ASS'Y.	PART NUMBER	SIZE							MATERIAL	MATERIAL SPECIFICATION
			BASE NO.	0812	1216	1620	2024	2432	3232		
① Swivel Flange	1	188-74045-	½-16	¾-20	1-24	1¼-32	1½-32	2-40	Alum. Bronze	C95800 or C95400	
② Nipple	1	FC3056-	1612-4	2016-4	2420-4				Monel	QQ-N-281	
② Nipple	1	FC3056-				3224-4	3232-4	4032-4	Monel	QQ-N-281 or QQ-N-286	
③ Socket	1	4-4010-	12		20	24	32	32	Monel	QQ-N-281	
③ Socket	1	4-4013-		16					Monel	QQ-N-281	

All dimensions in inches.

Additional flange fitting combinations using B-177 flanges are available on request.

Dimensional information is for reference only.

Variations from these dimensions, on actual parts, may occur as the result of engineering revisions.

# Hose Fittings

## High Pressure

**Mates with MIL-F-20042 150/400 lb. flange 90°  
FC9224-463**

**MIL-F-24787/1, Group I, Type FL, Class II**

for use with Hose 2766, AE371, AE373, FC163

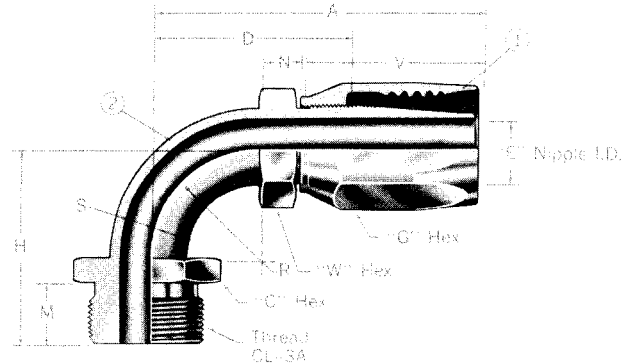

PART NUMBER	I.P.S. SIZE	NUMBER BOLT HOLES	DIMENSIONS													
			A	C	D	E	F	H	J	K	L	M	N	R	S	V
FC9224-0812-463	½	3	4.52	1.50	2.65	.61	.75	2.19	3.56	1.50	2.44	.56	.70	1.25	.71	2.47
FC9224-1216-463	¾	4	5.25	1.81	3.20	.82	1.00	2.49	3.81	1.84	2.69	.56	.70	1.50	.92	2.95
FC9224-1620-463	1	4	6.10	2.25	3.78	1.05	1.25	2.69	4.25	2.12	3.12	.56	.77	1.75	1.18	3.42
FC9224-2024-463	1¼	4	6.32	2.50	4.09	1.28	1.50	3.13	4.50	2.74	3.38	.56	.83	2.00	1.53	3.34
FC9224-2432-463	1½	6	7.38	3.00	4.94	1.75	2.00	3.35	5.06	2.74	3.94	.56	.83	2.50	1.77	3.70
FC9224-3232-463	2	6	7.38	3.00	4.94	1.75	2.00	3.35	5.56	3.28	4.44	.56	.83	2.50	1.77	3.70

COMPONENTS	REQ'D. PER ASS'Y.	PART NUMBER	SIZE							MATERIAL	MATERIAL SPECIFICATION
			0812	1216	1620	2024	2432	3232			
DESCRIPTION	BASE NO.										
① Swivel Flange	1	188-74045-	½-16	¾-20	1-24	1¼-32		2-40		Alum. Bronze	C95800 or C95400
② Socket	1	4-4010-	12		20	24	32	32		Monel	QQ-N-281
② Socket	1	4-4013-		16						Monel	QQ-N-281
③ Welded Nipple Assembly*	1	FC8223-	1612-4	2016-4	2420-4	3224-4		4032-4		see below	see below
③ Nipple Assembly	1	FC8224-						2432-176		see below	see below
Welded Nipple	1	4-461641-	12	16	20	24				Monel	QQ-N-281
Welded Nipple	1	4-461641-					32	32		Monel	QQ-N-281 or QQ-N-286
Elbow	1	4-419037-	12							Monel	MIL-T-1368
Elbow	1	15-419037-		16	20	24	32	32		Copper Nickel	MIL-T-16420
Shoulder	1	FC3245-	1612-4	2016-4	2420-4	3244-4	3232-4	4032-4		Monel	QQ-N-281
Flange	1	188-74045-					1½-32			Alum. Bronze	C95800 or C95400

All dimensions in inches.

Dimensional information is for reference only.

Variations from these dimensions, on actual parts, may occur as the result of engineering revisions.

\* In accordance with MIL-STD-278.

# Hose Fittings

## High Pressure

### SAE 37° flare swivel (JIC)

#### 4-4730

#### MIL-F-24787/2, Group II, Type A

for use with Hose FC162

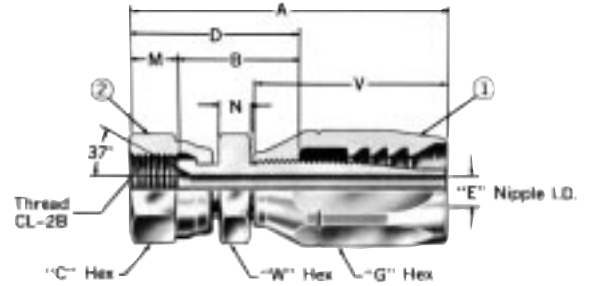

PART NUMBER	HOSE I.D.	THREAD	A	B	C	D	E	G	M	N	V	W	WT. EA. (LBS.)
4-4730-6-6	3/8	1/16-18	2.98	1.10	.69	1.50	.31	1.00	.40	.28	1.92	.69	.35
4-4730-8-8	1/2	3/4-16	3.20	1.24	.88	1.68	.39	1.12	.44	.31	2.01	.88	.53
4-4730-10-8	1/2	7/8-14	3.31	1.28	1.00	1.80	.39	1.12	.52	.31	2.01	1.00	.58
4-4730-12	3/4	1 1/16-12	3.86	1.42	1.25	1.99	.61	1.50	.57	.38	2.47	1.25	1.10
4-4730-16	1	1 1/8-12	4.48	1.83	1.50	2.43	.82	1.81	.60	.38	2.95	1.50	1.72

COMPONENTS	REQ'D. PER ASS'Y.	PART NUMBER	SIZE					MATERIAL	MATERIAL SPECIFICATION
			6-6	8-8	10-8	12	16		
DESCRIPTION		BASE NO.							
① Socket	1	4-4013-	6	8	8	12	16	Monel	QQ-N-281
② Nipple Assembly	1	4-4103-4-	6-6	8-8	10-8	12	16	Monel	see below
Nipple	1	4-4103-	6-6	8-8	10-8	12	16	Monel	QQ-N-281
Nut	1	4-210204-	6	8	10	12	16	Monel	QQ-N-281

All dimensions in inches.

Dimensional information is for reference only.

Variations from these dimensions, on actual parts, may occur as the result of engineering revisions.

# Hose Fittings

## High Pressure

### Male O-Ring seal union (CPV) 4-190885

MIL-F-24787/3, Group II, Type C

for use with Hose FC162

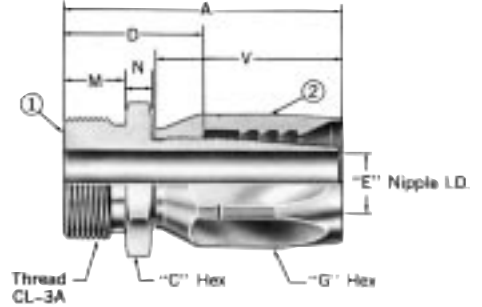

PART NUMBER	I.P.S. SIZE	THREAD	A	C	D	E	G	M	N	V	WT. EA. (LBS.)
4-190885-¼-6	¼	1½-12	2.82	1.25	1.34	.31	1.00	.62	.25	1.95	.54
4-190885-⅜-8	⅜	1½-12	2.96	1.44	1.45	.39	1.12	.62	.31	2.01	.76
4-190885-½-12	½	1½-12	3.49	1.81	1.62	.50	1.50	.62	.38	2.47	1.47
4-190885-¾-12	¾	2-12	3.61	2.12	1.74	.61	1.50	.62	.50	2.47	1.78
4-190885-1-16	1	2-12	4.09	2.12	2.04	.62	1.81	.62	.50	2.95	1.57
4-190885-1-16	1	2½-12	4.34	2.38	2.28	.82	1.81	.75	.62	2.95	2.78

COMPONENTS	REQ'D. PER ASS'Y.	PART NUMBER	SIZE						MATERIAL	MATERIAL SPECIFICATION
			BASE NO.	¼-6	⅜-8	½-12	¾-12	1-16		
① Nipple	1	4-220643-		¼-6	⅜-8	½-12	¾-12		Monel	QQ-N-281
① Nipple	1	4-220643-						¾-16 1-16	Monel	QQ-N-281 or QQ-N-286
② Socket	1	4-4013-	6	8	12	12	16	16	Monel	QQ-N-281
*Buna-N O-Ring	1	22550-	114	210	212	214	214	217	Buna-N	
*Butyl O-Ring	1	22015-	114	210	212	214	214	217	Butyl	

All dimensions in inches.

Dimensional information is for reference only.

Variations from these dimensions, on actual parts, may occur as the result of engineering revisions.

\*O-Ring not furnished with this assembly. Must be ordered separately.

# Hose Fittings

## High Pressure

### Male O-Ring seal union (CPV) 90° 4-191307

#### MIL-F-24787/3, Group II, Type CL

for use with Hose FC162

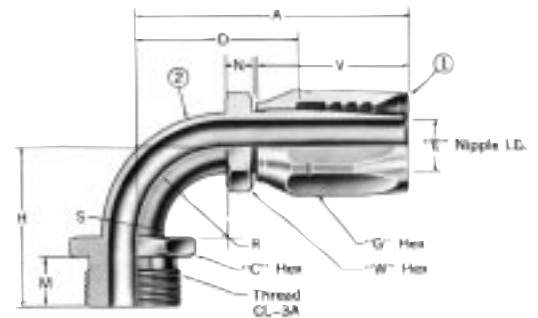

PART NUMBER	I.P.S. SIZE	THREAD	A	C	D	E	G	H	M	N	R	S	V	W	WT. EA. (LBS.)
4-191307-¼-6	¼	1½-12	3.11	1.25	1.63	.31	1.00	1.43	.62	.62	.50	.38	1.92	.69	.62
4-191307-⅜-8	⅜	1½-12	3.44	1.44	1.93	.39	1.12	1.74	.62	.62	.75	.50	2.01	.81	.92
4-191307-½-12	½	1¾-12	4.52	1.81	2.65	.61	1.50	2.31	.62	.74	1.25	.75	2.47	1.06	1.71
4-191307-¾-12	¾	2-12	4.52	2.12	2.65	.61	1.50	2.43	.62	.74	1.25	.75	2.47	1.06	2.13
4-191307-¾-16	¾	2-12	5.25	2.12	3.20	.82	1.81	2.68	.62	.74	1.50	1.00	2.95	1.38	2.82
4-191307-1-16	1	2½-12	5.25	2.38	3.20	.82	1.81	2.92	.75	.74	1.50	1.00	2.95	1.38	3.44

COMPONENTS DESCRIPTION	REQ'D. PER ASS'Y.	PART NUMBER BASE NO.	SIZE						MATERIAL	MATERIAL SPECIFICATION
			¼-6	⅜-8	½-12	¾-12	¾-16	1-16		
① Socket	1	4-4013-	6	8	12	12	16	16	Monel	QQ-N-281
② Welded Nipple Assembly*	1	4-186304-	¼-6	⅜-8	½-12	¾-12	¾-16	1-16	see below	see below
Nipple	1	4-461641-	6	8	12	12	16	16	Monel	QQ-N-281
Elbow	1	4-419037-	6	8	12	12			Monel	MIL-T-1368
Elbow	1	15-419037-					16	16	Copper Nickel	MIL-T-16420
Adapter	1	4-73461-	¼-6	⅜-8	½-12	¾-12	¾-16	1-16	Monel	QQ-N-281
**Buna-N O-Ring	1	22550-	114	210	212	214	214	217	Buna-N	
**Butyl O-Ring	1	22015-	114	210	212	214	214	217	Butyl	

All dimensions in inches.

\*In accordance with MIL-STD-278.

Variations from these dimensions, on actual parts, may occur as the result of engineering revisions.

\*\*O-Ring not furnished with this assembly. Must be ordered separately.

# Hose Fittings

## High Pressure

### Dogleg 90°

### 4-191308

### MIL-F-24787/5, Group II, Type D

for use with Hose FC162

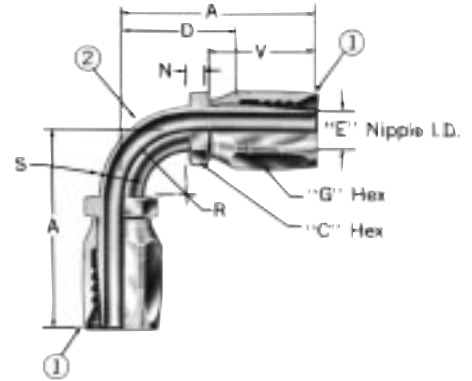

PART NUMBER	A	C	D	E	G	N	R	S	V	WT. EA. (LBS.)
4-191308-6	3.11	.69	1.63	.31	1.00	.62	.50	.38	1.92	.69
4-191308-8	3.44	.81	1.93	.39	1.12	.62	.75	.50	2.01	1.00
4-191308-12	4.52	1.06	2.65	.61	1.50	.74	1.25	.75	2.47	1.98
4-191308-16	5.25	1.38	3.20	.82	1.81	.74	1.50	1.00	2.95	3.43

COMPONENTS	REQ'D. PER ASS'Y.	PART NUMBER	SIZE				MATERIAL	MATERIAL SPECIFICATION
			6	8	12	16		
DESCRIPTION	BASE NO.							
① Socket	2	4-4013-	6	8	12	16	Monel	QQ-N-281
② Welded Nipple Assembly*	1	4-186305-	6	8	12	16	see below	see below
Nipple	2	4-461641-	6	8	12	16	Monel	QQ-N-281
Elbow	1	4-419037-	6	8	12		Monel	MIL-T-1368
Elbow	1	15-419037-				16	Copper Nickel	MIL-T-16420

All dimensions in inches.

\*Welded in accordance with MIL-STD-278.

Dimensional information is for reference only.

Variations from these dimensions, on actual parts, may occur as the result of engineering revisions.

# Hose Fittings

## High Pressure 4 Light Spiral

for use with Hose FC162

### Male pipe

4729-S

DASH SIZE	THREAD	HOSE SIZE	A	D	EØ
<b>4729-</b>					
6-6S	3/8-18	-6	2.75	1.27	.31
6-8S	3/8-18	-8	2.84	1.33	.39
8-8S	1/2-14	-8	3.09	1.58	.39
12-12S	3/4-14	-12	3.61	1.74	.61
16-16S	1-11 1/2	-16	4.40	2.35	.82

### SAE 37° (JIC) swivel

4730-S

DASH SIZE	THREAD	HOSE SIZE	A	D	EØ
<b>4730-</b>					
6-6S	9/16-18	-6	2.98	1.51	.31
8-6S	3/4-16	-6	3.11	1.63	.31
8-8S	3/4-16	-8	3.20	1.68	.39
10-8S	7/8-14	-8	3.31	1.80	.39
12S	1 1/16-12	-12	3.86	1.99	.61
16S	1 5/16-12	-16	4.48	2.43	.82

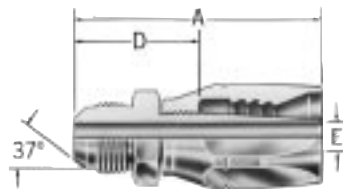

### SAE 37° (JIC) male flare

4706-S

DASH SIZE	THREAD	HOSE SIZE	A	D	EØ
<b>4706-</b>					
6-6S	9/16-18	-6	2.75	1.27	.30
8-6S	3/4-16	-6	2.91	1.43	.31
8-8S	3/4-16	-8	2.99	1.48	.39
10-8S	7/8-14	-8	3.10	1.58	.39
12S	1 1/16				

# Hose Fittings

## High Pressure 4 Light Spiral

for use with Hose FC162

### Material Specification Steel

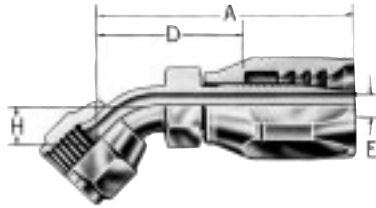

**SAE 37° (JIC) swivel 45° elbow**  
190470-S

DASH SIZE	THREAD	HOSE SIZE	A	D	EØ	H
<b>190470-</b>						
6S	9/16-18	-6	2.82	1.34	.31	.39
8-6S	3/4-16	-6	3.17	1.69	.31	.55
8S	3/4-16	-8	3.26	1.75	.39	.55
10-8S	7/8-14	-8	3.45	1.94	.39	.64
12S	1 1/16-12	-12	4.15	2.28	.61	.78
16S	1 5/16-12	-16	5.03	2.97	.82	1.07

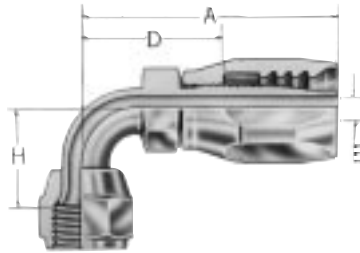

**SAE 37° (JIC) swivel 90° elbow (short)**  
190469-S

**SAE 37° (JIC) swivel 90° elbow (long)**  
190468-S

DASH SIZE	THREAD	HOSE SIZE	A	D	EØ	H
<b>190469-</b>						
6S	9/16-18	-6	2.72	1.24	.31	.85
8-6S	3/4-16	-6	2.94	1.46	.31	1.09
8S	3/4-16	-8	3.02	1.52	.39	1.09
10-8S	7/8-14	-8	3.15	1.64	.39	1.23
12S	1 1/16-12	-12	4.11	2.24	.61	1.82
16S	1 5/16-12	-16	4.84	2.78	.82	2.39
<b>190468-</b>						
6S	9/16-18	-6	2.72	1.24	.31	2.18
8-6S	3/4-16	-6	3.06	1.58	.31	2.43
8S	3/4-16	-8	3.15	1.64	.39	2.43
10-8S	7/8-14	-8	3.40	1.89	.39	2.57
12S	1 1/16-12	-12	4.11	2.24	.61	3.73
16S	1 5/16-12	-16	4.84	2.78	.82	4.58

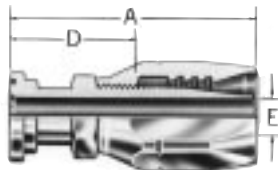

**Code 61 SAE J518c Straight split flange**  
474403-S

DASH SIZE	FLANGE HEAD DIA.	HOSE SIZE	A	D	EØ
<b>474403-</b>					
8S	1.19	-8	3.03	1.52	.39
12S	1.50	-12	3.53	1.66	.61
16-12S	1.75	-12	3.92	2.05	.61
16S	1.75	-16	4.65	2.59	.82
20-16S	2.00	-16	4.65	2.60	.82
24-16S	2.38	-16	4.72	2.66	.82

# Hose Fittings

## High Pressure

for use with Hose FC162

### Material Specification Steel

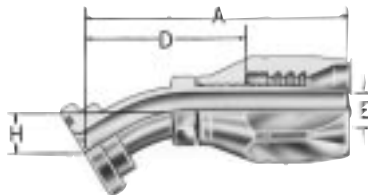

**Code 61 SAE J518c 22 1/2° split flange**  
472003-S

DASH SIZE	FLANGE HEAD DIA.	HOSE SIZE	A	D	EØ
<b>472003-</b>					
8S	1.19	-8	3.76	2.25	.50
12S	1.50	-12	4.32	2.44	.50
16S	1.75	-16	4.84	2.79	.50
20-16S	2.00	-16	4.84	2.79	.50

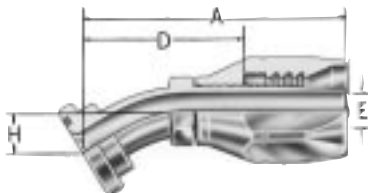

**Code 61 SAE J518c 30° split flange**  
190997-S

DASH SIZE	FLANGE HEAD DIA.	HOSE SIZE	A	D	EØ
<b>190997-</b>					
12S	1.50	-12	4.38	2.51	.69
16-12S	1.75	-12	4.38	2.51	.69
16S	1.75	-16	4.61	2.56	.50
20-16S	2.00	-16	4.61	2.56	.50

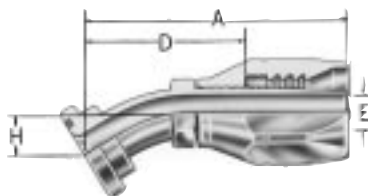

**Code 61 SAE J518c 45° split flange**  
474503-S

DASH SIZE	FLANGE HEAD DIA.	HOSE SIZE	A	D	EØ	H
<b>474503-</b>						
8S	1.19	-8	3.71	2.20	.39	1.00
12S	1.50	-12	4.34	2.47	.61	1.00
16-12S	1.75	-12	4.39	2.52	.61	1.00
16S	1.75	-16	5.09	3.04	.82	1.12
20-16S	2.00	-16	5.09	3.04	.82	1.12

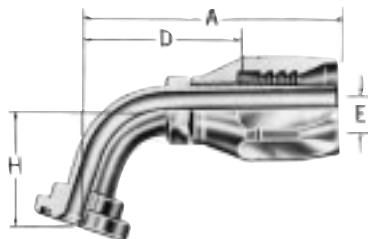

**Code 61 SAE J518c 60° split flange**  
476003-S

DASH SIZE	FLANGE HEAD DIA.	HOSE SIZE	A	D	EØ	H
<b>476003-</b>						
16S	1.75	-16	5.15	3.10	.82	1.64

All dimensions in inches.

Dimensional information is for reference only.

Variations from these dimensions, on actual parts, may occur as the result of engineering revisions.

# Hose Fittings

## High Pressure

for use with Hose FC162

### Material Specification Steel

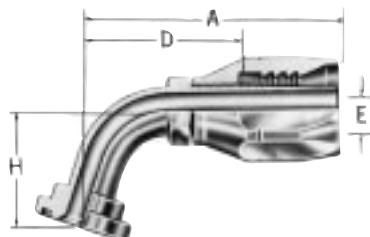

#### Code 61 SAE J518c 67½° split flange

476703-S

DASH SIZE	FLANGE HEAD DIA.	HOSE SIZE	A	D	EØ	H
<b>476703-</b>						
8S	1.19	-8	3.47	1.96	.39	1.38
12S	1.50	-12	4.37	2.50	.61	1.62
16-12S	1.75	-12	4.37	2.50	.61	1.62
16S	1.75	-16	5.07	3.02	.82	1.75
20-16S	2.00	-16	5.07	3.02	.82	1.75

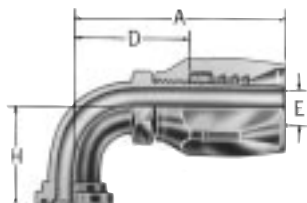

#### Code 61 SAE J518c 90° split flange (short)

479003-S

#### Code 61 SAE J518c 90° split flange (long)

479001-S

DASH SIZE	FLANGE HEAD DIA.	HOSE SIZE	A	D	EØ	H
<b>479003-</b>						
8S	1.19	-8	3.15	1.64	.39	1.62
12S	1.50	-12	4.11	2.24	.61	2.12
16-12S	1.75	-12	4.11	2.24	.61	2.12
16S	1.75	-16	4.84	2.79	.82	2.38
20-16S	2.00	-16	4.84	2.79	.82	2.38
<b>479001-</b>						
16S	1.75		4.84	2.79	.82	5.50
20-16S	2.00		4.84	2.79	.82	5.50

All dimensions in inches.

Dimensional information is for reference only.

Variations from these dimensions, on actual parts, may occur as the result of engineering revisions.

# Hose Fittings

## High Pressure

### SAE 37° flare swivel (JIC)

### FJ9364-41

### MIL-F-24787/2, Group VI, Type A

for use with Hose AE374

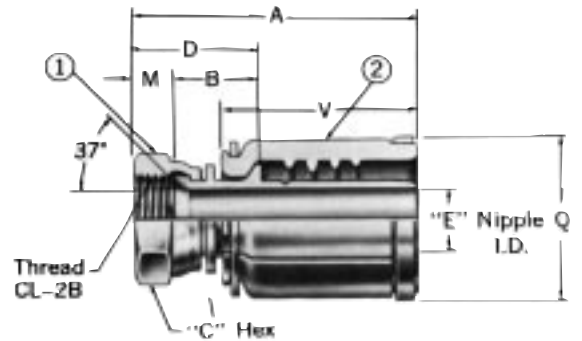

PART NUMBER	I.P.S. SIZE	THREAD	A	B	C	D	E	M	Q	V
FJ9364-2020-41	1 ¼	1 ½-12	4.91	1.69	2.00	2.33	1.05	.64	2.83	3.45
FJ9364-2424-41	1 ½	1 ½-12	5.44	1.88	2.25	2.62	1.26	.74	3.16	3.86
FJ9364-3232-41	2	2 ½-12	6.29	2.03	2.88	2.96	1.69	.93	3.65	4.46

COMPONENTS	REQ'D PER ASS'Y	PART NUMBER	SIZE			MATERIAL	MATERIAL SPECIFICATION
			20	24	32		
① Nipple Assembly	1	4-186348-	20	24	32	see below	see below
Nipple	1	4-220622-	20	24	32	Monel	QQ-N-286
Nut	1	4-210204-	20	24	32	Monel	QQ-N-281
② Socket Assembly	1	FC1198-	20S	24S	32S	see below	see below
Socket Segment	3	FC1198-1	20S	24S	32S	Steel	AISI 4140
Nose Ring	1	21027-	20S	24S	32S	Steel	AISI 4140
Retaining Ring	1	21028-	20S	24S	32S	Steel	AISI 4140

All dimensions in inches.

Dimensional information is for reference only.

Variations from these dimensions, on actual parts, may occur as the result of engineering revisions.

# Hose Fittings

## High Pressure

### Male O-Ring seal union (C.P.V.) FJ9366-41 MIL-F-24787/3, Group VI, Type C

for use with Hose AE374

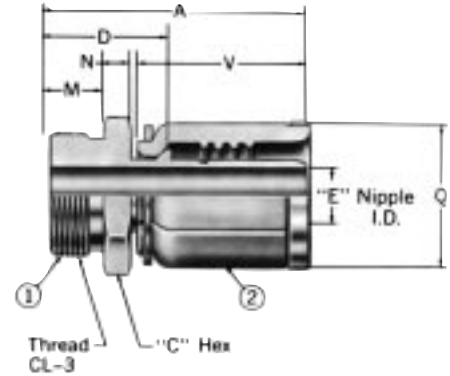

PART NUMBER	I.P.S. SIZE	THREAD	A	C	D	E	M	N	Q	V
FJ9366-1620-41	1	2 <sup>5</sup> / <sub>16</sub> -12	4.92	2.38	2.34	.81	.75	.62	2.83	3.45
FJ9366-2020-41	1 <sup>1</sup> / <sub>4</sub>	2 <sup>5</sup> / <sub>16</sub> -12	4.92	2.38	2.34	1.05	.75	.62	2.83	3.45
FJ9366-2024-41	1 <sup>1</sup> / <sub>4</sub>	2 <sup>5</sup> / <sub>16</sub> -12	5.23	2.88	2.42	1.26	.75	.62	3.16	3.86
FJ9366-2424-41	1 <sup>1</sup> / <sub>2</sub>	3 <sup>5</sup> / <sub>16</sub> -12	5.49	3.12	2.68	1.26	.88	.75	3.16	3.86
FJ9366-3232-41	2	3 <sup>5</sup> / <sub>16</sub> -12	5.95	3.88	2.62	1.69	.88	.62	3.65	4.46

COMPONENTS DESCRIPTION	REQ'D. PER ASS'Y.	PART NUMBER BASE NO.	SIZE					MATERIAL	MATERIAL SPECIFICATION
			1620	2020	2024	2424	3232		
① Nipple	1	4-220657-	1-20	1 <sup>1</sup> / <sub>4</sub> -20	1 <sup>1</sup> / <sub>4</sub> -24	1 <sup>1</sup> / <sub>2</sub> -24	2-32	Monel	QQ-N-286
② Socket Assembly	1	FC1198-	20S	20S	24S	24S	32S	see below	
Socket Segment	3	FC1198-1-	20S	20S	24S	24S	32S	Steel	AISI 4140
Nose Ring	1	21027-	20S	20S	24S	24S	32S	Steel	AISI 4140
Retaining Ring	1	21028-	20S	20S	24S	24S	32S	Steel	AISI 4140
*Buna-N O-Ring	1	22550-	217	222	222	224	227	Buna-N	
*Butyl O-Ring	1	22015-	217	222	222	224	227	Butyl	

\*O-Ring not furnished with this assembly.  
Must be ordered separately.

All dimensions in inches.

Dimensional information is for reference only.

Variations from these dimensions, on actual parts, may occur as the result of engineering revisions.

# Hose Fittings

## High Pressure

### Male O-Ring seal union (C.P.V.) 90° FJ9368-41

#### MIL-F-24787/3, Group VI, Type CL

for use with Hose AE374

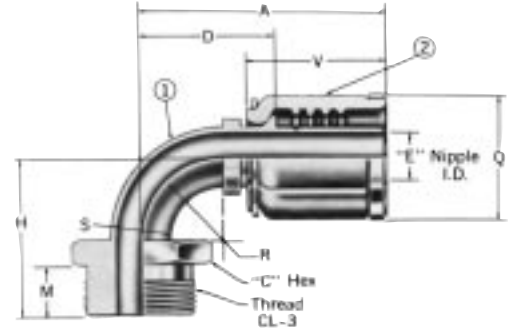

Part Number	I.P.S. size	Thread	A	C	D	E	H	M	Q	R	S	V
FJ9368-2424-41	1½	3¼-12	7.07	3.12	4.26	1.12	3.95	.88	3.16	2.00	1.50	3.86
FJ9368-3232-41	2	3¼-12	8.80	3.88	5.47	1.43	4.49	.88	3.65	3.00	2.00	4.46
FJ9368-2020-41	1¼	2¼-12	6.25	2.88	3.68	.87	3.32	.75	2.83	1.75	1.25	3.45

COMPONENTS DESCRIPTION	REQ'D. PER ASS'Y.	PART NUMBER BASE NO.	SIZE			MATERIAL	MATERIAL SPECIFICATION
			2020	2424	3232		
① Welded Nipple Assembly**	1	FJ8368-	2020 -4	2424 -4	3232 -4	see below	
Nipple	1	4-220655-	20	24	32	Monel	QQ-N-286
Elbow	1	FC1236-	20-15	24-15	32-15	Copper Nickel	MIL-T-16420
Adapter	1	4-73461-	1¼-20	1½-24	2-32	Monel	QQ-N-281
② Socket Assembly	1	FC1198-	20S	24S	32S	see below	
Socket Segment	3	FC1198-1	20S	24S	32S	Steel	4140
Nose Ring	1	21027-	20S	24S	32S	Steel	4140
Retaining Ring	1	21028-	20S	24S	32S	Steel	4140
*Buna-N O-Ring	1	22550-	222	224	227	Buna	
*Butyl O-Ring	1	22015-	222	224	227	Butyl	

\*O-Ring not furnished with this assembly.  
Must be ordered separately.

\*\*Welded in Accordance with MIL-STD-278.

All dimensions in inches.

Dimensional information is for reference only.

Variations from these dimensions, on actual parts, may occur as the result of engineering revisions.

# Hose Fittings

## High Pressure

### Dogleg 90° FJ9343-41

#### MIL-F-24787/6, Group VI, Type D

for use with Hose AE374

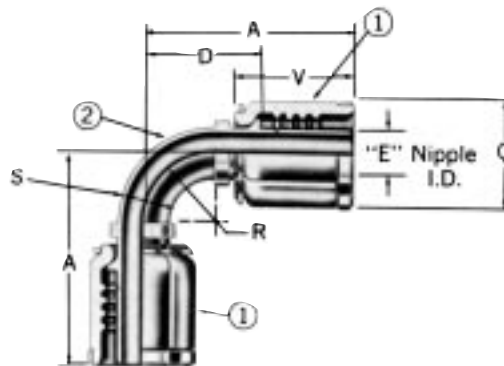

PART NUMBER	A	D	E	Q	R	S	V
FJ9343-2020-41	6.26	3.68	1.05	2.83	1.75	1.25	3.45
FJ9343-2424-41	7.07	4.26	1.12	3.16	2.00	1.50	3.86
FJ9343-3232-41	7.98	4.58	1.69	3.66	2.50	2.00	4.46

COMPONENTS DESCRIPTION	REQ'D. PER ASS'Y.	PART NUMBER BASE NO.	SIZE			MATERIAL	MATERIAL SPECIFICATION
			2020	2424	3232		
① Socket Assembly	2	FC1198-	20S	24S	32S	see below	
Socket Segment	6	FC1198-1-	20S	24S	32S	Steel	AISI 4140
Nose Ring	2	21027-	20S	24S	32S	Steel	AISI 4140
Retaining Ring	2	21028-	20S	24S	32S	Steel	AISI 4140
② Welded Nipple Assembly*	1	FJ8343-		2424		see below	
	1	4-186314	20	-4	32	see below	
Nipple	2	4-220655-	20	24	32	Monel	QQ-N-286
Elbow	1	FC1236-		24-5		Copper Nickel	MIL-T-16420
Elbow	1	15-419036-	20		32	Copper Nickel	MIL-T-16420

\*Welded in accordance with MIL-STD-278.

All dimensions in inches.

Dimensional information is for reference only.

Variations from these dimensions, on actual parts, may occur as the result of engineering revisions.

# Hose Fittings

## High Pressure

### Dogleg 180°

### FJ9369-41

### MIL-F-24787/6, Group VI, Type U

for use with Hose AE374

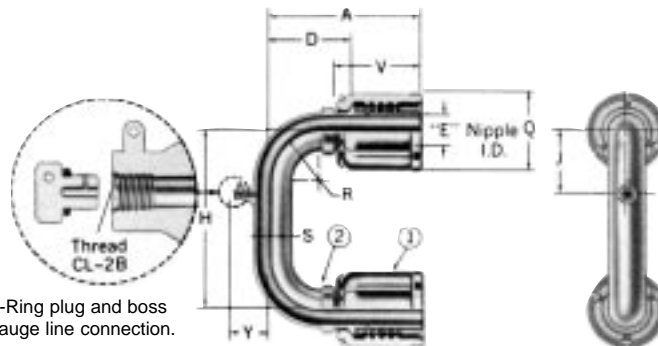

PART NUMBER	THREAD	A	D	E	H	J	Q	R	S	V	Y
FJ9369-2424-41	5/16-24	7.07	4.26	1.26	6.50	2.50	3.16	2.00	1.50	3.86	1.75

COMPONENTS DESCRIPTION	REQ'D. PER ASS'Y.	PART NUMBER		MATERIAL	MATERIAL SPECIFICATION
		BASE NO.	SIZE		
① Socket Assembly	2	FC1198-	24S	see below	
Socket Segment	6	FC1198-1-	24S	Steel	AISI 4140
Nose Ring	2	21027-	24S	Steel	AISI 4140
Retaining Ring	2	21028-	24S	Steel	AISI 4140
② Welded Nipple Assembly**	1	4-186324-	24	see below	
Nipple	2	4-220655-	24	Monel	QQ-N-286
Elbow	1	15-400226-	24	Copper Nickel	MIL-T-16420
Thread Boss	1	4-73458-	24	Monel	QQ-N-281
Clip	1	4-222075-	1	Monel	QQ-N-281
Plug*	1	4-2223-	2	Monel	QQ-N-281

\*Optional.

\*\*Welded in accordance with MIL-STD-278.

All dimensions in inches.

Dimensional information is for reference only.

Variations from these dimensions, on actual parts, may occur as the result of engineering revisions.

# Hose Fittings

## Large Bore

### Dogleg 90° 375-190717

#### MIL-F-24787/5, Group IV, Type D

for use with Hose 150901, AE370

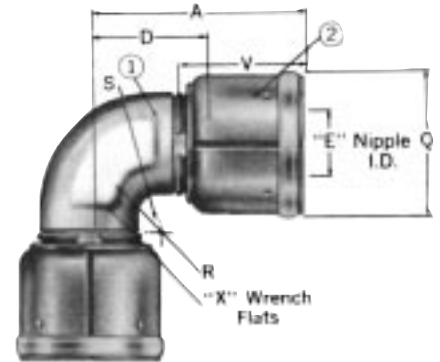

PART NUMBER	A	D	E	Q	R	S	V	X	WT. EA. WT.
375-190717-40	5.70	2.87	2.05	3.90	1.88	3.00	3.69	2.75	11.6
375-190717-48	5.96	3.08	2.50	4.50	2.09	3.50	3.69	3.19	14.5
375-190717-64	6.75	3.94	3.45	5.44	2.81	4.75	3.69	4.50	22.5

COMPONENTS DESCRIPTION	REQ'D. PER ASS'Y.	PART NUMBER BASE NO.	SIZE			MATERIAL	MATERIAL SPECIFICATION
			40	48	64		
① Nipple	1	188-185215-	40	48	64	Alum. Bronze	C95800
② Socket Assembly	2	4-1205-	40	48	64	Monel	see below
Socket Segment	8	4-1205-1-	40	48	64	Monel	QQ-N-288
Ring	2	4-21004-	40	48	64	Monel	QQ-N-286 or QQ-N-288
Band	2	4-21023-	40	48	64	Monel	QQ-N-286 or QQ-N-288

All dimensions in inches.

Dimensional information is for reference only.

Variations from these dimensions, on actual parts, may occur as the result of engineering revisions.

# Hose Fittings

## Large Bore

**Mates with A.N.S.I. B16.5 150 lb. flange  
375-190767**

**MIL-F-24787/1, Group IV, Type F, Class V**

for use with Hose 150901, AE370

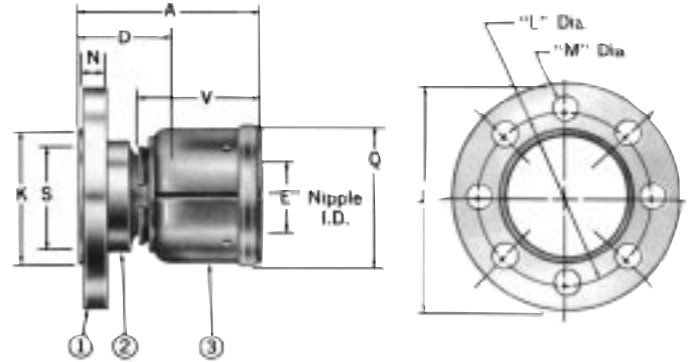

PART NUMBER	I.P.S. SIZE	NUMBER BOLT HOLES	A	D	E	J	K	L	M	N	Q	S	V	WT. EA. (LBS.)
375-190767-2-40	2	4	5.16	2.34	2.06	6.00	3.28	4.75	.75	.44	3.90	2.24	3.69	8.58
375-190767-2½-40	2½	4	5.16	2.34	2.06	7.00	3.28	5.50	.75	.50	3.90	2.24	3.69	10.81
375-190767-2½-48	2½	4	5.17	2.30	2.51	7.00	3.78	5.50	.75	.50	4.50	2.71	3.69	11.68
375-190767-3-48	3	4	5.17	2.30	2.51	7.50	4.50	6.00	.75	.50	4.50	3.31	3.69	11.97
375-190767-3½-64	3½	8	5.54	2.74	3.45	8.50	5.22	7.00	.75	.50	5.44	3.81	3.69	17.00
375-190767-4-64	4	8	5.54	2.74	3.45	9.00	5.22	7.50	.75	.50	5.44	4.28	3.69	18.05

COMPONENTS DESCRIPTION	REQ'D. PER ASS'Y.	PART NUMBER BASE NO.	SIZE						MATERIAL	MATERIAL SPECIFICATION
			2-40	2½-40	2½-48	3-48	3½-64	4-64		
① Swivel Flange	1	188-74021-	2-40	2½-40	2½-48	3-48	3½-64	4-64	Alum. Bronze	C954800 or C95400
② Nipple	1	188-4112-	40	40	2½-48	3-48	3½-64	4-64	Alum. Bronze	C95800
③ Socket Assembly	1	4-1205-	40	40	48	48	64	64	Monel	see below
Socket Segment	4	4-1205-1-	40	40	48	48	64	64	Monel	QQ-N-288
Ring	1	4-21004-	40	40	48	48	64	64	Monel	QQ-N-286 or QQ-N-288
Band	1	4-21023-	40	40	48	48	64	64	Monel	QQ-N-286 or QQ-N-288

All dimensions in inches.

Dimensional information is for reference only.

Variations from these dimensions, on actual parts, may occur as the result of engineering revisions.

# Hose Fittings

## Large Bore

### Mates with A.N.S.I. B16.5 150 lb. flange 412-190767

for use with Hose 150901, AE370

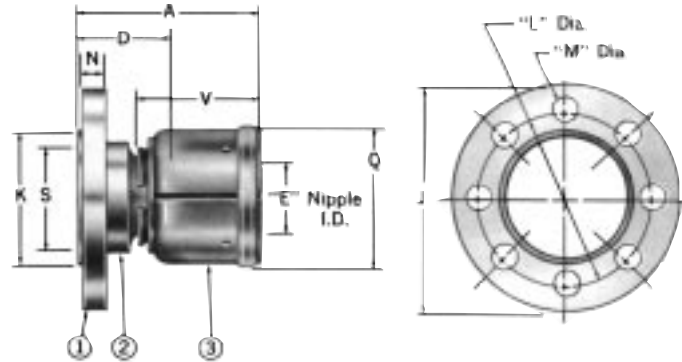

PART NUMBER	I.P.S. SIZE	NUMBER BOLT HOLES											WT. EA. (LBS.)	
			A	D	E	J	K	L	M	N	Q	S		V
412-190767-2-40	2	4	5.16	2.34	2.06	6.00	3.28	4.75	.75	.44	3.90	2.24	3.69	8.58
412-190767-2½-40	2½	4	5.16	2.34	2.06	7.00	3.28	5.50	.75	.50	3.90	2.24	3.69	10.81
412-190767-2½-48	2½	4	5.17	2.30	2.51	7.00	3.78	5.50	.75	.50	4.50	2.71	3.69	11.68
412-190767-3-48	3	4	5.17	2.30	2.51	7.50	4.50	6.00	.75	.50	4.50	3.31	3.69	11.97
412-190767-3½-64	3½	8	5.54	2.74	3.45	8.50	5.22	7.00	.75	.50	5.44	3.81	3.69	17.00
412-190767-4-64	4	8	5.54	2.74	3.45	9.00	5.22	7.50	.75	.50	5.44	4.28	3.69	18.05

COMPONENTS DESCRIPTION	REQ'D. PER ASS'Y.	PART NUMBER BASE NO.	SIZE			MATERIAL	MATERIAL SPECIFICATION
			2-40	2½-40	3-48		
① Swivel Flange	1	407-74021-	2½-40	2½-48	3-48	Stainless Steel	316
② Nipple	1	407-4112-	40	2½-48	3-48	Stainless Steel	316
③ Socket Assembly	1	4-1205-	40	48	48	see below	see below
Socket Segment	4	4-1205-1-	40	48	48	Monel	QQ-N-288
Ring	1	4-21004-	40	48	48	Monel	QQ-N-286 or QQ-N-288
Band	1	4-21023-	40	48	48	Monel	QQ-N-286 or QQ-N-288

All dimensions in inches.

Dimensional information is for reference only.

Variations from these dimensions, on actual parts, may occur as the result of engineering revisions.

# Hose Fittings

## Large Bore

**Mates with MIL-F-20042 150 lb. flange  
375-190655  
MIL-F-24787/1, Group IV, Type F, Class IV**  
for use with Hose 150901, AE370

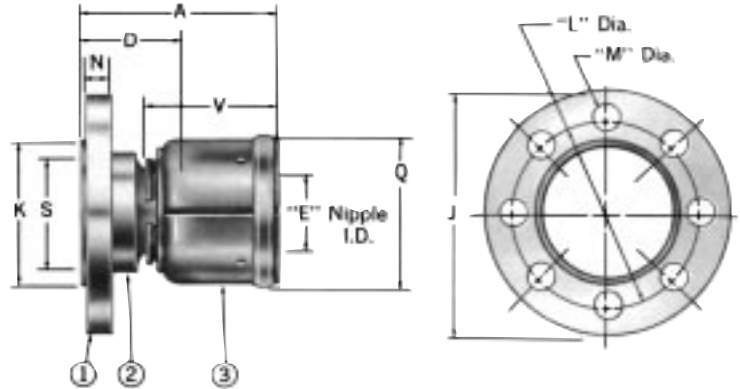

PART NUMBER	I.P.S. SIZE	NUMBER BOLT HOLES	A	D	E	J	K	L	M	N	Q	S	V	WT. EA. (LBS.)
375-190655-2-40	2	6	5.16	2.34	2.06	5.56	3.28	4.44	.56	.44	3.90	2.24	3.69	8.12
375-190655-2½-40	2½	6	5.16	2.34	2.06	6.12	3.28	5.00	.56	.50	3.90	2.24	3.69	9.21
375-190655-2½-48	2½	6	5.17	2.30	2.51	6.12	3.78	5.00	.56	.50	4.50	2.71	3.69	10.27
375-190655-3-48	3	8	5.17	2.30	2.51	6.62	4.50	5.50	.56	.50	4.50	3.31	3.69	10.41
375-190655-3½-64	3½	8	5.54	2.74	3.45	7.19	5.22	6.06	.56	.50	5.44	3.81	3.69	14.62
375-190655-4-64	4	8	5.54	2.74	3.45	7.69	5.22	6.56	.56	.50	5.44	4.28	3.69	15.61

COMPONENTS	REQ'D. PER ASS'Y.	PART NUMBER	SIZE						MATERIAL	MATERIAL SPECIFICATION	
			BASE NO.	2-40	2½-40	2½-48	3-48	3½-64			4-64
① Swivel Flange	1	188-180005-		2-40	2½-40	2½-48	3-48	3½-64	4-64	Alum. Bronze	C95800 or C95400
② Nipple	1	188-4112-		40	40	2½-48	3-48	3½-64	4-64	Alum. Bronze	C95800
③ Socket Assembly	1	4-1205-		40	40	48	48	64	64	Monel	see below
Socket Segment	4	4-1205-1-		40	40	48	48	64	64	Monel	QQ-N-288
Ring	1	4-21004-		40	40	48	48	64	64	Monel	QQ-N-286 or QQ-N-288
Band	1	4-21023-		40	40	48	48	64	64	Monel	QQ-N-286 or QQ-N-288

All dimensions in inches.

Dimensional information is for reference only.

Variations from these dimensions, on actual parts, may occur as the result of engineering revisions.

# Hose Fittings

## Larg Bore

**Mates with MIL-F-20042 150/400 lb. flange  
375-190751**

**MIL-F-24787/1, Group IV, Type F, Class II**

for use with Hose 150901, AE370

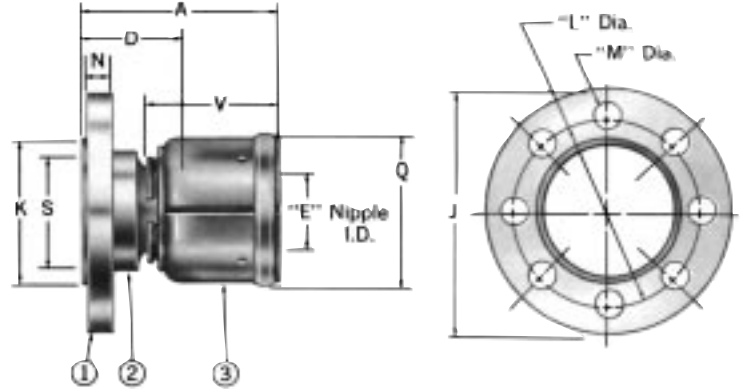

PART NUMBER	I.P.S. SIZE	NUMBER BOLT HOLES	A	D	E	J	K	L	M	N	Q	S	V	WT. EA. (LBS.)
375-190751-2-40	2	6	5.16	2.34	2.06	5.56	3.28	4.44	.56	.81	3.90	2.24	3.69	10.23
375-190751-2½-40	2½	6	5.16	2.34	2.06	6.12	3.28	5.00	.56	.94	3.90	2.24	3.69	11.94
375-190751-2½-48	2½	6	5.17	2.30	2.51	6.12	3.78	5.00	.56	.94	4.50	2.71	3.69	12.81
375-190751-3-48	3	8	5.17	2.30	2.51	6.62	4.50	5.50	.56	.94	4.50	3.31	3.69	13.04
375-190751-3½-64	3½	8	5.54	2.74	3.45	7.19	5.22	6.06	.56	1.00	5.44	3.81	3.69	17.90
375-190751-4-64	4	8	5.54	2.74	3.45	7.69	5.22	6.56	.56	1.00	5.44	4.28	3.69	19.80

COMPONENTS	REQ'D. PER ASS'Y.	PART NUMBER	SIZE						MATERIAL	MATERIAL SPECIFICATION	
			BASE NO.	2-40	2½-40	2½-48	3-48	3½-64			4-64
① Swivel Flange	1	188-74045-		2-40	2½-40	2½-48	3-48	3½-64	4-64	Alum. Bronze	C95800 or C95400
② Nipple	1	188-4112-		40	40	2½-48	3-48	3½-64	4-64	Alum. Bronze	C95800
③ Socket Assembly	1	4-1205-		40	40	48	48	64	64	Monel	see below
Socket Segment	4	4-1205-1-		40	40	48	48	64	64	Monel	QQ-N-288
Ring	1	4-21004-		40	40	48	48	64	64	Monel	QQ-N-286 or QQ-N-288
Band	1	4-21023-		40	40	48	48	64	64	Monel	QQ-N-286 or QQ-N-288

All dimensions in inches.

Dimensional information is for reference only.

Variations from these dimensions, on actual parts, may occur as the result of engineering revisions.

# Hose Fittings

## Larg Bore

**Mates with MIL-F-20042 400 lb. flange  
375-190752**

**MIL-F-24787/1, Group IV, Type F, Class I**

for use with Hose 150901, AE370

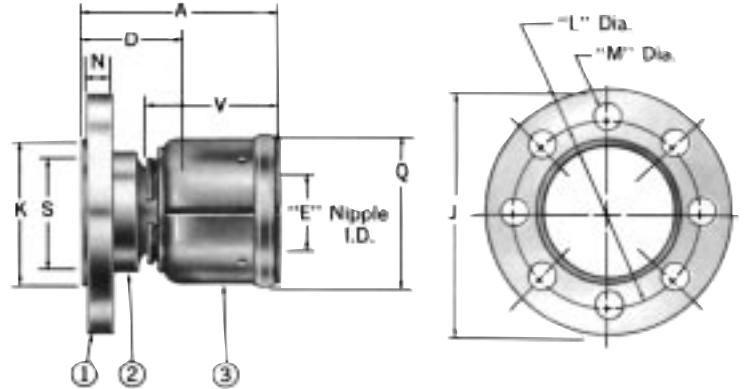

PART NUMBER	I.P.S. SIZE	NUMBER BOLT HOLES	A	D	E	J	K	L	M	N	Q	S	V	WT. EA. (LBS.)
375-190752-2-40	2	7	5.16	2.34	2.06	6.50	3.28	5.19	.69	.83	3.90	2.24	3.69	11.96
375-190752-2½-48	2½	8	5.17	2.30	2.51	7.56	3.78	6.00	.81	.95	4.50	2.71	3.69	16.68
375-190752-3-48	3	8	5.17	2.30	2.51	8.12	4.50	6.56	.81	.95	4.50	3.31	3.69	17.49
375-190752-3½-64	3½	9	5.54	2.74	3.45	8.69	5.22	7.12	.81	1.02	5.44	3.81	3.69	22.90
375-190752-4-64	4	9	5.54	2.74	3.45	9.25	5.22	7.69	.81	1.02	5.44	4.28	3.69	25.63

COMPONENTS	REQ'D. PER ASS'Y.	PART NUMBER	SIZE						MATERIAL	MATERIAL SPECIFICATION	
			BASE NO.	2-40	2½-40	2½-48	3-48	3½-64			4-64
① Swivel Flange	1	188-74048-		2-40	2½-40	2½-48	3-48	3½-64	4-64	Alum. Bronze	C95800 or C95400
② Nipple	1	188-4112-		40	40	2½-48	3-48	3½-64	4-64	Alum. Bronze	C95800
③ Socket Assembly	1	4-1205-		40	40	48	48	64	64	Monel	see below
Socket Segment	4	4-1205-1-		40	40	48	48	64	64	Monel	QQ-N-288
Ring	1	4-21004-		40	40	48	48	64	64	Monel	QQ-N-286 or QQ-N-288
Band	1	4-21023-		40	40	48	48	64	64	Monel	QQ-N-286 or QQ-N-288

All dimensions in inches.

Dimensional information is for reference only.

Variations from these dimensions, on actual parts, may occur as the result of engineering revisions.

# Hose Fittings

## Large Bore

### A.N.S.I. B16.5 600 lb. flange 412-190814

for use with Hose 150901, AE370

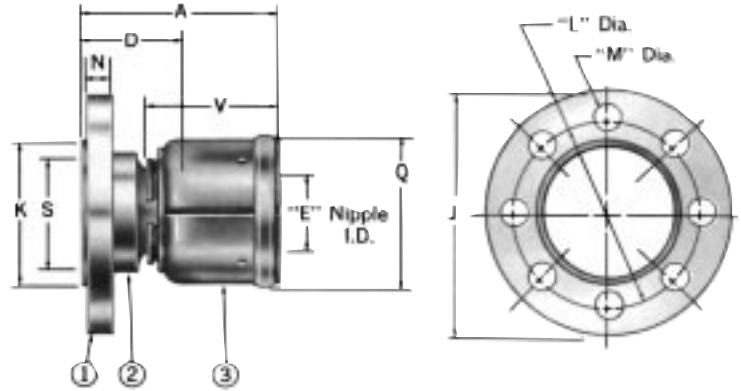

PART NUMBER	I.P.S. SIZE	NUMBER BOLT HOLES	A	D	E	J	K	L	M	Q	S	V
412-190814-2½-40	2½	8	5.16	2.34	2.06	7.50	3.28	5.88	.88	3.91	2.24	3.69

DESCRIPTION	REQ'D. PER ASS'Y.	PART NUMBER		MATERIAL	MATERIAL SPECIFICATION
		BASE NO.	SIZE		
① Swivel Flange	1	407-74031-	2½-40	Stainless Steel	316
② Nipple	1	407-4112-	40	Stainless Steel	316
③ Socket Assembly	1	4-1205-	40	see below	see below
Socket Segment	4	4-1205-1-	40	Monel	QQ-N-286
Ring	1	4-21004-	40	Monel	QQ-N-286 or QQ-N-288
Band	1	4-21023-	40	Monel	QQ-N-286 or QQ-N-288

All dimensions in inches.

Dimensional information is for reference only.

Variations from these dimensions, on actual parts, may occur as the result of engineering revisions.

# Hose Fittings

## Large Bore

**Mates with A.N.S.I. B16.5 150 lb. flange 90°  
375-190769**

**MIL-F-24787/1, Group IV, Type FL, Class V**

for use with Hose 150901, AE370

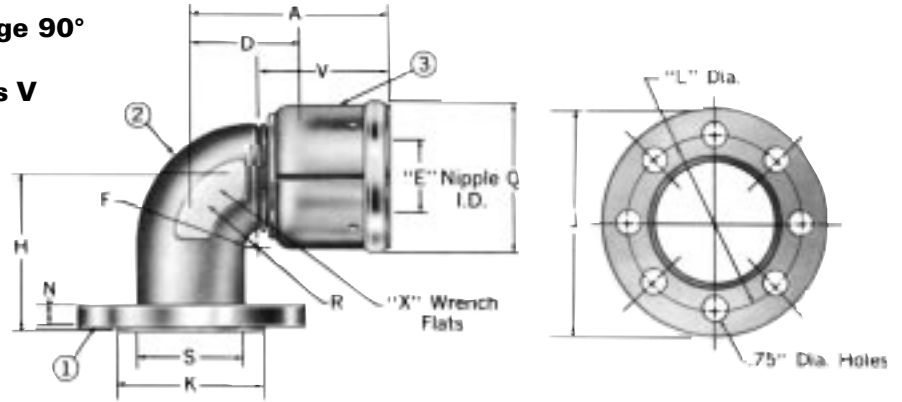

PART NUMBER	I.P.S. SIZE	NUMBER BOLT HOLES	A	D	E	F	H	J	K	L	N	Q	R	S	V	X	WT. EA. (LBS.)
375-190769-2-40	2	4	5.70	2.87	2.05	3.00	3.50	6.00	3.28	4.75	.44	3.90	1.88	2.24	3.69	2.75	9.48
375-190769-2½-40	2½	4	5.70	2.87	2.05	3.00	3.50	7.00	3.28	5.50	.50	3.90	1.88	2.24	3.69	2.75	11.72
375-190769-2½-48	2½	4	5.96	3.08	2.50	3.50	4.00	7.00	3.78	5.50	.50	4.50	2.09	2.71	3.69	3.19	13.43
375-190769-3-48	3	4	5.96	3.08	2.50	3.50	4.00	7.50	4.50	6.00	.50	4.50	2.09	3.31	3.69	3.19	14.49
375-190769-3½-64	3½	8	6.75	3.94	3.45	4.75	4.62	8.50	5.22	7.00	.50	5.44	2.81	3.81	3.69	4.50	21.44
375-190769-4-64	4	8	6.75	3.94	3.45	4.75	4.62	9.00	5.22	7.50	.50	5.44	2.81	4.28	3.69	4.50	22.49

COMPONENTS	REQ'D. PER ASS'Y.	PART NUMBER	SIZE						MATERIAL	MATERIAL SPECIFICATION
			BASE NO.	2-40	2½-40	2½-48	3-48	3½-64		
① Swivel Flange	1	188-74021-	2-40	2½-40	2½-48	3-48	3½-64	4-64	Alum. Bronze	C95800 or C95400
② Nipple	1	188-185212-	40	40	2½-48	3-48	3½-64	4-64	Alum. Bronze	C95800
③ Socket Assembly	1	4-1205-	40	40	48	48	64	64	Monel	see below
Socket Segment	4	4-1205-1-	40	40	48	48	64	64	Monel	QQ-N-288
Ring	1	4-21004-	40	40	48	48	64	64	Monel	QQ-N-286 or QQ-N-288
Band	1	4-21023-	40	40	48	48	64	64	Monel	QQ-N-286 or QQ-N-288

All dimensions in inches.

Dimensional information is for reference only.

Variations from these dimensions, on actual parts, may occur as the result of engineering revisions.

# Hose Fittings

## Large Bore

### Mates with A.N.S.I. B16.5 150 lb. flange 90° 413-190769

for use with Hose 150901, AE370

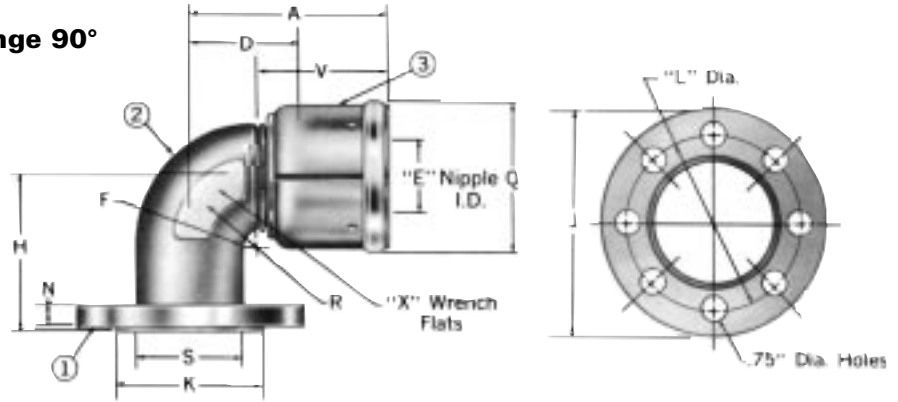

PART NUMBER	I.P.S. SIZE	NUMBER BOLT HOLES	A	D	E	F	H	J	K	L	N	Q	R	S	V	X	WT. EA. (LBS.)
413-190769-2-40	2	4	5.70	2.87	2.05	3.00	3.50	6.00	3.28	4.75	.44	3.90	1.88	2.24	3.69	2.75	9.48
413-190769-2½-40	2½	4	5.70	2.87	2.05	3.00	3.50	7.00	3.28	5.50	.50	3.90	1.88	2.24	3.69	2.75	11.72
413-190769-2½-48	2½	4	5.96	3.08	2.50	3.50	4.00	7.00	3.78	5.50	.50	4.50	2.09	2.71	3.69	3.19	13.43
413-190769-3-48*	3	4	5.96	3.08	2.50	3.50	4.00	7.50	4.50	6.00	.50	4.50	2.09	3.31	3.69	3.19	14.49
413-190769-3½-64	3½	8	6.75	3.94	3.45	4.75	4.62	8.50	5.22	7.00	.50	5.44	2.81	3.81	3.69	4.50	21.44
413-190769-4-64	4	8	6.75	3.94	3.45	4.75	4.62	9.00	5.22	7.50	.50	5.44	2.81	4.28	3.69	4.50	22.49

COMPONENTS	REQ'D. PER ASS'Y.	PART NUMBER	SIZE	MATERIAL	MATERIAL SPECIFICATION
DESCRIPTION		BASE NO.			
① Swivel Flange	1	407-74021-	3-48	Stainless Steel	316
② Nipple	1	188-185212-	3-48	Alum. Bronze	C95800
③ Socket Assembly	1	4-1205-	48	see below	see below
Socket Segment	4	4-1205-1-	48	Monel	QQ-N-288
Ring	1	4-21004-	48	Monel	QQ-N-286 or QQ-N-288
Band	1	4-21023-	48	Monel	QQ-N-286 or QQ-N-288

# Hose Fittings

## Large Bore

**Mates with MIL-F-20042 150 lb. flange 90°  
375-190656**

**MIL-F-24787/1, Group IV, Type FL, Class IV**

for use with Hose 150901, AE370

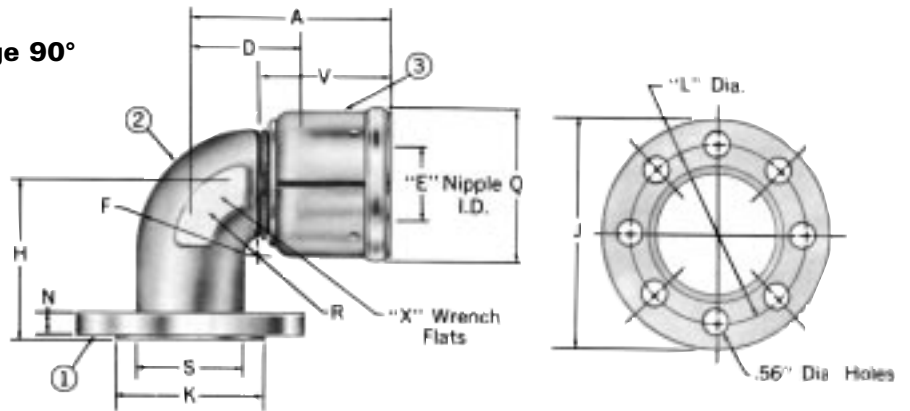

PART NUMBER	I.P.S. SIZE	NUMBER BOLT HOLES	A	D	E	F	H	J	K	L	N	Q	R	S	V	X	WT. EA. (LBS.)
375-190656-2-40	2	6	5.70	2.87	2.05	3.00	3.50	5.56	3.28	4.44	.44	3.90	1.88	2.24	3.69	2.75	9.02
375-190656-2½-40	2½	6	5.70	2.87	2.05	3.00	3.50	6.12	3.28	5.00	.50	3.90	1.88	2.24	3.69	2.75	10.12
375-190656-2½-48	2½	6	5.96	3.08	2.50	3.50	4.00	6.12	3.78	5.00	.50	4.50	2.09	2.71	3.69	3.19	12.02
375-190656-3-48	3	8	5.96	3.08	2.50	3.50	4.00	6.62	4.50	5.50	.50	4.50	2.09	3.31	3.69	3.19	12.93
375-190656-3½-64	3½	8	6.75	3.94	3.45	4.75	4.62	7.19	5.22	6.06	.50	5.44	2.81	3.81	3.69	4.50	19.06
375-190656-4-64	4	8	6.75	3.94	3.45	4.75	4.62	7.69	5.22	6.56	.50	5.44	2.81	4.28	3.69	4.50	20.05

COMPONENTS	REQ'D. PER ASS'Y.	PART NUMBER	SIZE						MATERIAL	MATERIAL SPECIFICATION	
			BASE NO.	2-40	2½-40	2½-48	3-48	3½-64			4-64
① Swivel Flange	1	188-80005-		2-40	2½-40	2½-48	3-48	3½-64	4-64	Alum. Bronze	C95800 or C95400
② Nipple	1	188-185212-		40	40	2½-48	3-48	3½-64	4-64	Alum. Bronze	C95800
③ Socket Assembly	1	4-1205-		40	40	48	48	64	64	Monel	see below
Socket Segment	4	4-1205-1-		40	40	48	48	64	64	Monel	QQ-N-288
Ring	1	4-21004-		40	40	48	48	64	64	Monel	QQ-N-286 or QQ-N-288
Band	1	4-21023-		40	40	48	48	64	64	Monel	QQ-N-286 or QQ-N-288

All dimensions in inches.

Dimensional information is for reference only.

Variations from these dimensions, on actual parts, may occur as the result of engineering revisions.

# Hose Fittings

## Large Bore

**Mates with MIL-F-20042 150/400 lb. flange 90°  
375-190757**

**MIL-F-24787/1, Group IV, Type FL, Class II**

for use with Hose 150901, AE370

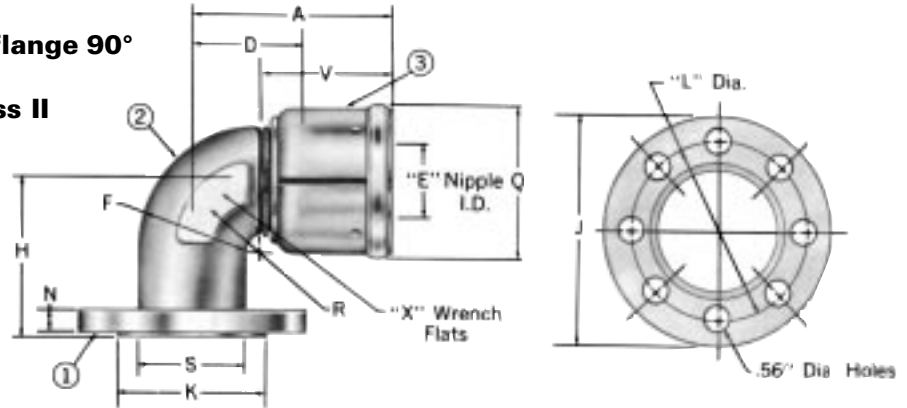

PART NUMBER	I.P.S. SIZE	NUMBER BOLT HOLES	A	D	E	F	H	J	K	L	N	Q	R	S	V	X	WT. EA. (LBS.)
375-190757-2-40	2	6	5.70	2.87	2.05	3.00	3.50	5.56	3.28	4.44	.83	3.90	1.88	2.24	3.69	2.75	11.14
375-190757-2½-40	2½	6	5.70	2.87	2.05	3.00	3.50	6.12	3.28	5.00	.95	3.90	1.88	2.24	3.69	2.75	12.84
375-190757-2½-48	2½	6	5.96	3.08	2.50	3.50	4.00	6.12	3.78	5.00	.95	4.50	2.09	2.71	3.69	3.19	14.56
375-190757-3-48	3	8	5.96	3.08	2.50	3.50	4.00	6.62	4.50	5.50	.95	4.50	2.09	3.31	3.69	3.19	15.56
375-190757-3½-64	3½	8	6.75	3.94	3.45	4.75	4.62	7.19	5.22	6.06	1.02	5.44	2.81	3.81	3.69	4.50	22.34
375-190757-4-64	4	8	6.75	3.94	3.45	4.75	4.62	7.69	5.22	6.56	1.02	5.44	2.81	4.28	3.69	4.50	24.24

COMPONENTS	REQ'D. PER ASS'Y.	PART NUMBER	SIZE						MATERIAL	MATERIAL SPECIFICATION	
			BASE NO.	2-40	2½-40	2½-48	3-48	3½-64			4-64
① Swivel Flange	1	188-74045-		2-40	2½-40	2½-48	3-48	3½-64	4-64	Alum. Bronze	C95800 or C95400
② Nipple	1	188-185212-		40	40	2½-48	3-48	3½-64	4-64	Alum. Bronze	C95800
③ Socket Assembly	1	4-1205-		40	40	48	48	64	64	Monel	see below
Socket Segment	4	4-1205-1-		40	40	48	48	64	64	Monel	QQ-N-288
Ring	1	4-21004-		40	40	48	48	64	64	Monel	QQ-N-286 or QQ-N-288
Band	1	4-21023-		40	40	48	48	64	64	Monel	QQ-N-286 or QQ-N-288

All dimensions in inches.

Dimensional information is for reference only.

Variations from these dimensions, on actual parts, may occur as the result of engineering revisions.

# Hose Fittings

## Large Bore

**Mates with MIL-F-20042 150/400 lb. flange 90°  
375-190758**

**MIL-F-24787/1, Group IV, Type FL, Class I**

for use with Hose 150901, AE370

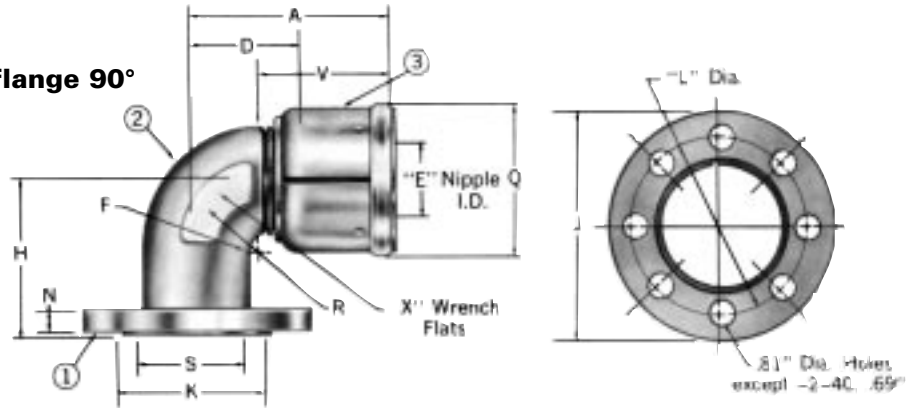

PART NUMBER	I.P.S. SIZE	NUMBER BOLT HOLES	A	D	E	F	H	J	K	L	N	Q	R	S	V	X	WT. EA. (LBS.)
375-190758-2-40	2	7	5.70	2.87	2.05	3.00	3.50	6.50	3.28	5.19	.81	3.90	1.88	2.24	3.69	2.75	12.87
375-190758-2½-48	2½	8	5.96	3.08	2.50	3.50	4.00	7.56	3.78	6.00	.94	4.50	2.09	2.71	3.69	3.19	18.43
375-190758-3-48	3	8	5.96	3.08	2.50	3.50	4.00	8.12	4.50	6.56	.94	4.50	2.09	3.31	3.69	3.19	20.01
375-190758-3½-64	3½	9	6.75	3.94	3.45	4.75	4.62	8.69	5.22	7.12	1.00	5.44	2.81	3.81	3.69	4.50	27.34
375-190758-4-64	4	9	6.75	3.94	3.45	4.75	4.62	9.25	5.22	7.69	1.00	5.44	2.81	4.28	3.69	4.50	30.07

COMPONENTS	REQ'D. PER ASS'Y.	PART NUMBER	SIZE					MATERIAL	MATERIAL SPECIFICATION
			BASE NO.	2-40	2½-48	3-48	3½-64		
① Swivel Flange	1	188-74048-	2-40	2½-48	3-48	3½-64	4-64	Alum. Bronze	C95800 or C95400
② Nipple	1	188-185212-	40	2½-48	3-48	3½-64	4-64	Alum. Bronze	C95800
③ Socket Assembly	1	4-1205-	40	48	48	64	64	Monel	see below
Socket Segment	4	4-1205-1-	40	48	48	64	64	Monel	QQ-N-288
Ring	1	4-21004-	40	48	48	64	64	Monel	QQ-N-286 or QQ-N-288
Band	1	4-21023-	40	48	48	64	64	Monel	QQ-N-286 or QQ-N-288

All dimensions in inches.

Dimensional information is for reference only.

Variations from these dimensions, on actual parts, may occur as the result of engineering revisions.

# Hose Fittings

## Large Bore

### Male Sil-Braze split clamp FC9583-375, 375-190780 MIL-F-24787/4, Group IV, Type E

for use with Hose 150901, AE370

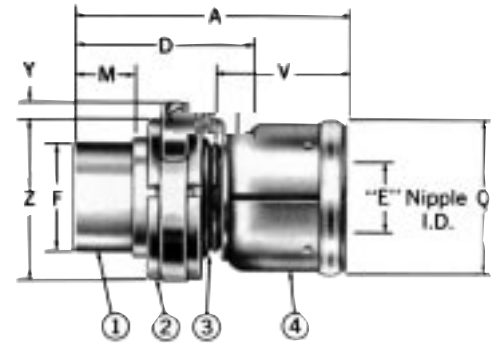

PART NUMBER	I.P.S. SIZE	A	D	E	F	M	Q	V	Y	Z	WT. EA. (LBS.)
*FC9583-3240-375	2	6.61	3.78	2.06	2.38	1.31	3.90	3.69	.39	4.00	8.48
*FC9583-4048-375	2½	6.60	3.73	2.51	2.88	1.12	4.50	3.69	.39	4.42	9.92
375-190780-3-48	3	8.01	5.14	2.51	3.50	2.50	4.50	3.69	.39	5.19	13.62
375-190780-3½-64	3½	8.02	5.21	3.45	4.00	2.50	5.44	3.69	.39	5.56	16.30
375-190780-4-64	4	8.38	5.47	3.45	4.50	2.64	5.44	3.69	.39	6.12	17.62

COMPONENTS	REQ'D. PER ASS'Y.	PART NUMBER	SIZE					MATERIAL	MATERIAL SPECIFICATION
			BASE NO.	3240	4048	3-48	3½-64		
① Tailpiece Assembly	1	188-500189- FF5002-188	32	40	3	3½	4	Alum. Bronze	C95800 or C95400
② Clamp Assembly	1	900758-	2	2½	3	3½	4	Bronze	see page 125
③ Nipple	1	188-1239-	2-40	2½-48	3-48	3½-64	4-64	Alum. Bronze	C95800
④ Socket Assembly	1	4-1205-	40	48	48	64	64	Monel	see below
Socket Segment	4	4-1205-1-	40	48	48	64	64	Monel	QQ-N-288
Ring	1	4-21004-	40	48	48	64	64	Monel	QQ-N-286 or QQ-N-288
Band	1	4-21023-	40	48	48	64	64	Monel	QQ-N-286 or QQ-N-288

\*FC9583 same as 190780 except tailpiece is designed for ultrasonic testing.

All dimensions in inches.

Dimensional information is for reference only.

Variations from these dimensions, on actual parts, may occur as the result of engineering revisions.

# Hose Fittings

## Large Bore

### Female Sil-Braze split clamp FC9073-375, 375-190781 MIL-F-24787/4, Group IV, Type E

for use with Hose 150901, AE370

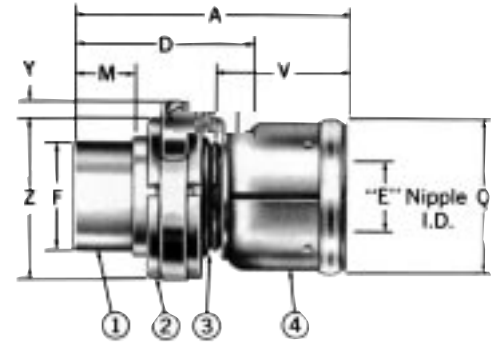

PART NUMBER	I.P.S. SIZE	A	B	D	E	F	M	Q	V	Y	Z	WT. EA. (LBS.)
*FC9073-3240-375	2	6.10	2.61	3.27	2.06	2.38	.66	3.90	3.69	.39	4.00	8.49
*FC9073-4048-375	2½	6.42	2.77	3.55	2.51	2.88	.78	4.50	3.69	.39	4.42	9.73
375-190781-3-48	3	6.11	2.40	3.23	2.51	3.50	.83	4.50	3.69	.39	5.19	11.90
375-190781-3½-64	3½	6.16	2.47	3.35	3.45	4.00	.88	5.44	3.69	.39	5.56	14.48
375-190781-4-64	4	6.31	2.59	3.50	3.45	4.50	.91	5.44	3.69	.39	6.12	15.93

COMPONENTS DESCRIPTION	REQ'D. PER ASS'Y.	PART NUMBER BASE NO.	SIZE					MATERIAL	MATERIAL SPECIFICATION
			3240	4048	3-48	3½-64	4-64		
① Tailpiece		188-500063- FF5001-188	32	40	3	3½	4	Alum. Bronze	C95800 or C95400
② Clamp Assembly	1	900758-	2	2½	3	3 1/2	4	Alum. Bronze	see page 125
③ Nipple	1	188-1239-	2-40	2½-48	3-48	3½-64	4-64	Alum. Bronze	C95800
④ Socket Assembly	1	4-1205-	40	48	48	64	64	Monel	see below
Socket Segment	4	4-1205-1-	40	48	48	64	64	Monel	QQ-N-288
Ring	1	4-21004-	40	48	48	64	64	Monel	QQ-N-286 or QQ-N-288
Band	1	4-21023-	40	48	48	64	64	Monel	QQ-N-286 or QQ-N-288

\*FC9073 same as 190781 except tailpiece is designed for ultrasonic testing.

All dimensions in inches.

Dimensional information is for reference only.

Variations from these dimensions, on actual parts, may occur as the result of engineering revisions.

# Hose Fittings

## Large Bore

### Sil-Braze split clamp 90° FC9589-375 375-190784 MIL-F-24787/4, Group IV, Type EL

for use with Hose 150901, AE370

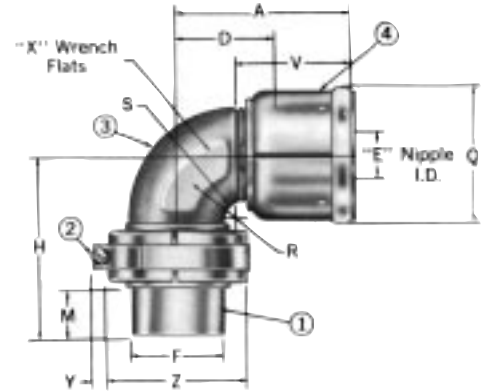

PART NUMBER	I.P.S. SIZE	A	D	E	F	H	M	Q	R	S	V	X	Y	Z	WT. EA. (LBS.)
*FC9589-3240-375	2	5.70	2.87	2.05	2.38	4.76	1.31	3.90	1.88	3.00	3.69	2.75	.39	4.00	9.80
*FC9589-4048-375	2½	5.88	3.18	2.50	2.88	4.71	1.12	4.50	2.09	3.50	3.69	3.19	.39	4.42	12.01
375-190784-3-48	3	6.46	3.58	2.50	3.50	6.15	2.50	4.50	2.09	3.50	3.69	3.19	.39	5.19	16.47
375-190784-3½-64	3½	6.75	3.94	3.45	4.00	6.99	2.50	5.44	2.81	4.75	3.69	4.50	.39	5.56	21.67
375-190784-4-64	4	6.75	3.94	3.45	4.50	7.24	2.64	5.44	2.81	4.75	3.69	4.50	.39	6.12	23.92

COMPONENTS	REQ'D. PER ASS'Y.	PART NUMBER	SIZE					MATERIAL	MATERIAL SPECIFICATION	
			BASE NO.	3240	4048	3-48	3½-64			4-64
① Tailpiece Assembly	1	188-500189-FF5002-188		32	40	3	3½	4	Alum. Bronze	C95800 or C95400
② Clamp Assembly	1	900758-		2	2½	3	3½	4	Bronze	see page 125
③ Nipple	1	188-185203-		2-40	2½-48	3-48	3½-64	4-64	Alum. Bronze	C95800
④ Socket Assembly	1	4-1205-		40	48	48	64	64	Monel	see below
Socket Segment	4	4-1205-1-		40	48	48	64	64	Monel	QQ-N-288
Ring	1	4-21004-		40	48	48	64	64	Monel	QQ-N-286 or QQ-N-288
Band	1	4-21023-		40	48	48	64	64	Monel	QQ-N-286 or QQ-N-288

\*FC9589 same as 190784 except tailpiece is designed for ultrasonic testing.

All dimensions in inches.

Dimensional information is for reference only.

Variations from these dimensions, on actual parts, may occur as the result of engineering revisions.

# Hose Fittings

## Large Bore

### Female Sil-Braze split clamp 90° FC9074-375, 375-190785 MIL-F-24787/4, Group IV, Type EL

for use with Hose 150901, AE370

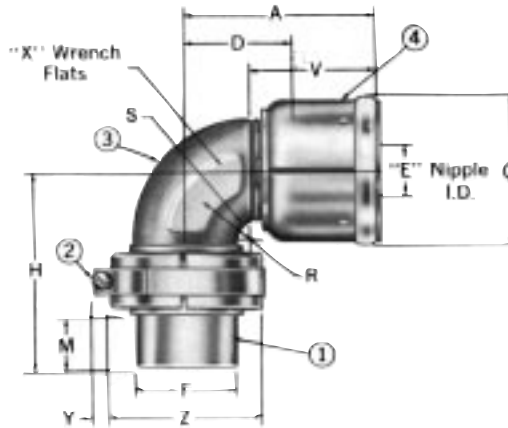

PART NUMBER	I.P.S. SIZE	A	D	E	F	H	M	Q	R	S	V	X	Y	Z	WT. EA. (LBS.)
*FC9074-3240-375	2	5.56	2.87	2.05	2.38	4.21	.66	3.90	1.88	3.00	3.69	2.75	.39	4.00	9.81
*FC9074-4048-375	2½	5.88	3.18	2.50	2.88	4.51	.78	4.50	2.09	3.50	3.69	3.19	.39	4.12	11.82
375-190785-3-48	3	6.46	3.58	2.50	3.50	4.25	.83	4.50	2.09	3.50	3.69	3.19	.39	5.19	14.75
375-190785-3½-64	3 1/2	6.75	3.94	3.45	4.00	5.14	.88	5.44	2.81	4.75	3.69	4.50	.39	5.56	19.83
375-190785-4-64	4	6.75	3.94	3.45	4.50	5.27	.91	5.44	2.81	4.75	3.69	4.50	.39	6.12	22.23

COMPONENTS	REQ'D. PER ASS'Y.	PART NUMBER	SIZE					MATERIAL	MATERIAL SPECIFICATION
			BASE NO.	3240	4048	3-48	3½-64		
① Tailpiece Assembly	1	188-500063- FF5001-188	32	40	3-	3½-	4	Alum. Bronze	C95800 or C95400
② Clamp Assembly	1	900758-	2	2½	3	3½	4	Bronze Monel	see page 125
③ Nipple	1	188-185203-	2-40	2½-48	3-48	3½-64	4-64	Bronze	C95800
④ Socket Assembly	1	4-1205-	40	48	48	64	64	Monel	see below
Socket Segment	4	4-1205-1-	40	48	48	64	64	Monel	QQ-N-288
Ring	1	4-21004-	40	48	48	64	64	Monel	QQ-N-286 or QQ-N-288
Band	1	4-21023-	40	48	48	64	64	Monel	QQ-N-286 or QQ-N-288

\*FC9074 same as 190785 except tailpiece is designed for ultrasonic testing.

All dimensions in inches.

Dimensional information is for reference only.

Variations from these dimensions, on actual parts, may occur as the result of engineering revisions.

# Hose Fittings

## Large Bore

### Split clamp 180°

### 375-190786

### MIL-F-24787/6, Group IV, Type U

for use with Hose 150901, AE370

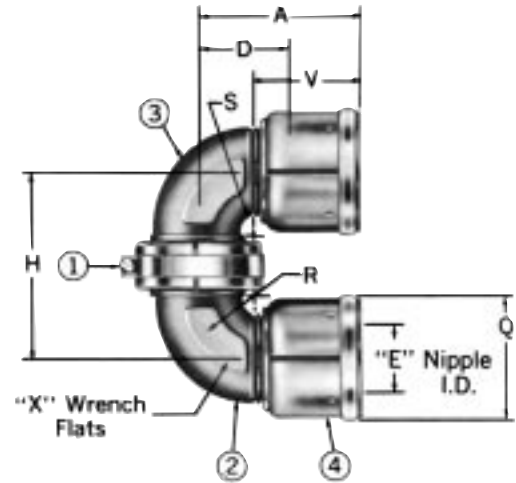

PART NUMBER	A	D	E	H	Q	R	S	V	X	WT. EA. (LBS.)
375-190786-2-40	5.70	2.87	2.05	5.40	3.90	1.88	3.00	3.69	2.75	15.36
375-190786-2½-48	6.05	3.18	2.50	5.92	4.50	2.09	3.50	3.69	3.19	20.94
375-190786-3-48	6.46	3.58	2.50	5.95	4.50	2.09	3.50	3.69	3.19	22.84
375-190786-3½-64	6.75	3.94	3.45	7.32	5.44	2.81	4.75	3.69	4.50	33.54
375-190786-4-64	6.75	3.94	3.45	7.44	5.44	2.81	4.75	3.69	4.50	35.64

COMPONENTS DESCRIPTION	REQ'D. PER ASS'Y.	PART NUMBER BASE NO.	SIZE					MATERIAL	MATERIAL SPECIFICATION
			2-40	2½-48	3-48	3½-64	4-64		
① Clamp Assembly	1	900758-	2	2½	3	3½	4	Bronze	see page 125
O-Ring	1	22020-	230	234	239	243	247	Buna-N	
Back-up Ring	1	22006-	8	12				Leather	
② Nipple	1	188-185204-	2-40	2½-48	3-48	3½-64	4-64	Alum. Bronze	C95800
③ Nipple	1	188-185203-	2-40	2½-48	3-48	3½-64	4-64	Alum. Bronze	C95800
④ Socket Assembly	2	4-1205-	40	48	48	64	64	Monel	see below
Socket Segment	8	4-1205-1	40	48	48	64	64	Monel	QQ-N-288
Ring	2	4-21004-	40	48	48	64	64	Monel	QQ-N-286 or QQ-N-288
Band	2	4-21023-	40	48	48	64	64	Monel	QQ-N-286 or QQ-N-288

All dimensions in inches.

Dimensional information is for reference only.

Variations from these dimensions, on actual parts, may occur as the result of engineering revisions.

# Hose Fittings

## Large Bore

### Dogleg 90° 473-190215 MIL-F-24787/5, Group VII Type D

for use with Hose 2758

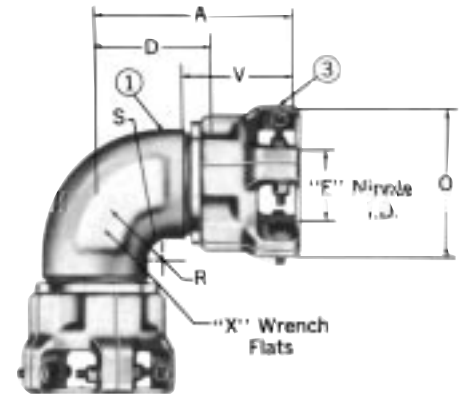

PART NUMBER	A	D	E	Q	R	S	V	X	WT. EA. (LBS.)
473-190215-80	10.78	6.38	4.40	8.45	4.50	5.88	5.90	5.62	72.12
473-190215-96	11.08	6.69	5.37	9.41	4.75	6.94	5.89	6.62	81.17

DESCRIPTION	REQ'D. PER ASS'Y.	PART NUMBER BASE NO.	SIZE		MATERIAL	MATERIAL SPECIFICATION
			80	96		
① Nipple	1	188-185215-	80	96	Alum. Bronze	C95800
③ Socket Assembly	2	474-1218-	80	96	Bronze	See page 107

For assembly instructions, see page 173

### Mates with MIL-F-20042 150/400 lb. flange 473-190388 MIL-F-24787/1, Group VII, Type F, Class II

for use with Hose 2758

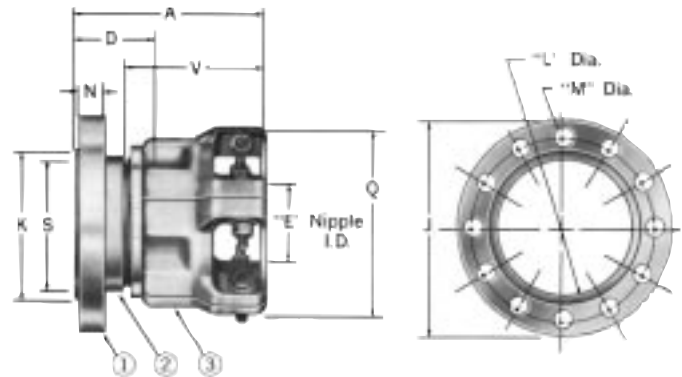

PART NUMBER	I.P.S. SIZE	NUMBER BOLT HOLES	A	D	E	J	K	L	M	N	Q	S	V	WT. EA. (LBS.)
473-190388-5-80	5	10	7.31	2.91	4.40	9.06	6.37	7.81	.69	1.08	8.45	5.32	5.90	44.38
473-190388-6-96	6	12	7.30	2.91	5.40	10.12	7.37	8.88	.69	1.20	9.41	6.36	5.89	52.16

DESCRIPTION	REQ'D. PER ASS'Y.	PART NUMBER BASE NO.	SIZE		MATERIAL	MATERIAL SPECIFICATION
			5-80	6-96		
① Swivel Flange	1	188-74045-	5-80	6-96	Alum. Bronze	C95800 or C95400
② Nipple	1	188-4112-	5-80	6-96	Alum. Bronze	C95800
③ Socket Assembly	1	474-1218-	80	96	Bronze	See page 107

All dimensions in inches.

Dimensional information is for reference only.

Variations from these dimensions, on actual parts, may occur as the result of engineering revisions.

# Hose Fittings

## Large Bore

**Mates with MIL-F-20042 150/400 lb. flange 90°  
473-190390**

**MIL-F-24787/1, Group VII, Type FL, Class II**

for use with Hose 2758

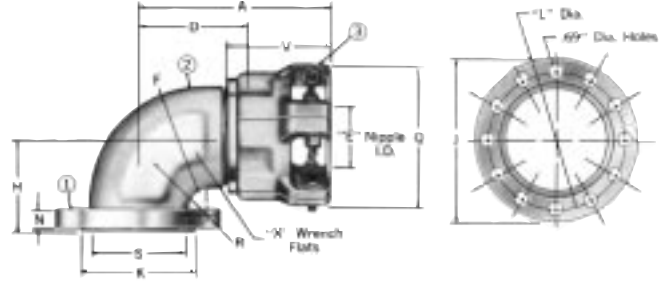

PART NUMBER	I.P.S. SIZE	NUMBER BOLT HOLES	A	D	E	F	H	J	K	L	N	Q	R	S	V	X	WT. EA. (LBS.)
473-190390-5-80	5	10	10.78	6.38	4.40	5.88	5.05	9.06	6.37	7.81	1.06	8.45	4.50	5.32	5.90	5.62	55.25
473-190390-6-96	6	12	11.08	6.69	5.37	6.94	5.67	10.12	7.37	8.88	1.19	9.41	4.75	6.36	5.89	6.62	66.79

COMPONENTS DESCRIPTION	REQ'D. PER ASS'Y.	PART NUMBER		MATERIAL	MATERIAL SPECIFICATION
		BASE NO.	SIZE		
① Swivel Flange	1	188-74045-	5-80 6-96	Alum. Bronze	C95800 or C95400
② Nipple	1	188-185212-	5-80 6-96	Alum. Bronze	C95800
③ Socket Assembly	1	474-1218-	80 96	Bronze	See page 107

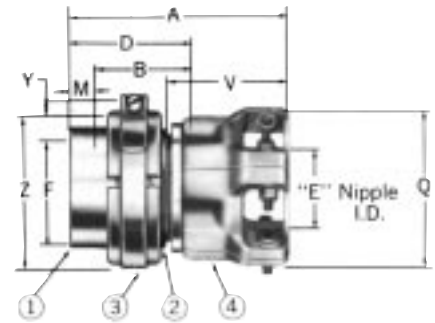

I.P.S.

WT. EA.

COMPONENTS DESCRIPTION	REQ'D. PER ASS'Y.	PART NUMBER		MATERIAL	MATERIAL SPECIFICATION
		BASE NO.	SIZE		
① Tailpiece Assembly	1	188-500063-	5 6	Alum. Bronze	C95800 or C95400
② Nipple	1	188-1239-	5-80 6-96	Alum. Bronze	C95800
③ Clamp Assembly	1	900758-	5 6	Bronze	See page 125
④ Socket Assembly	1	474-1218-	80 96	Bronze	See page 107

All dimensions in inches.  
Dimensional information is for reference only.  
Variations from these dimensions, on actual parts, may occur as the result of engineering revisions.

# Hose Fittings

## Large Bore

### Female Sil-Braze split clamp 90° 473-190210 MIL-F-24787/4, Group VII, Type EL

for use with Hose 2758

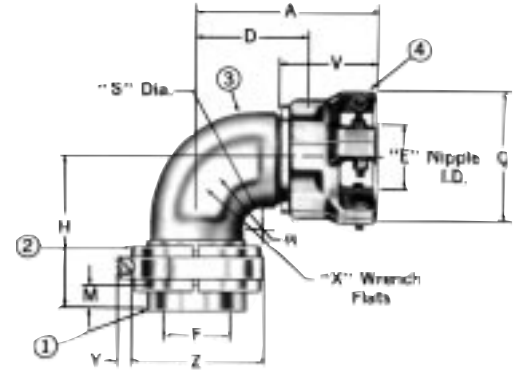

PART NUMBER	I.P.S. SIZE	A	D	E	F	H	M	Q	R	S	V	X	Y	Z	WT. EA. (LBS.)
473-190210-5-80	5	10.78	6.38	4.40	5.57	7.02	1.00	8.45	4.50	5.88	5.90	5.62	.39	7.31	54.11
473-190210-6-96	6	11.08	6.69	5.37	6.63	7.91	1.11	9.41	4.75	6.94	5.89	6.62	.39	8.25	63.78

COMPONENTS	REQ'D. PER ASS'Y.	PART NUMBER		MATERIAL	MATERIAL SPECIFICATION
		BASE NO.	SIZE		
① Tailpiece Assembly	1	188-500063	5 80 6 96	Alum. Bronze	C95800 or C95400
② Clamp Assembly	1	900758-	5 80 6 96	Alum. Bronze	See page 125
③ Nipple	1	188-185203-	5-80 6-96	Alum. Bronze	C95800
④ Socket Assembly	1	474-1218-	80 96	Alum. Bronze	See page 107

### Socket Assembly segment type 474-1218

for use with Hose 2758

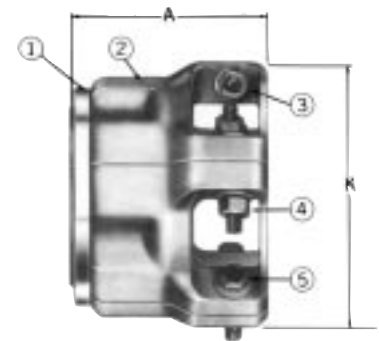

PART NUMBER	A	K	WT. EA. (LBS.)
474-1218-80	5.90	8.45	23.76
474-1218-96	5.89	9.41	25.96

COMPONENTS	REQ'D. PER ASS'Y.	PART NUMBER		MATERIAL	MATERIAL SPECIFICATION
		BASE NO.	SIZE		
① Ring	1	4-21004-	80 96	Monel	
② Segment	5	474-1218-1-	80 96	Bronze	C86100
③ Bolt	5	4-210005-	8-60 8-60	Monel	QQ-N-286
④ Washer	10	4-210100-	8-3 8-3	Monel	Commercial
⑤ Nut	5	4-210200-	8-2 8-2	Monel	QQ-N-281

All dimensions in inches.

Dimensional information is for reference only.

Variations from these dimensions, on actual parts, may occur as the result of engineering revisions.

# Hose Fittings

## Large Bore

Mates with MIL-F-20042 150/400 lb. flange\*\*

**FC7750-188**

MIL-F-24787/1

Group IX, Type F, Class II

Mates with 150 lb. A.N.S.I.

Commercial flange B16.5\*\*

**FC7781-188**

MIL-F-24787/1

Group IX, Type F, Class V

for use with Hose 2580

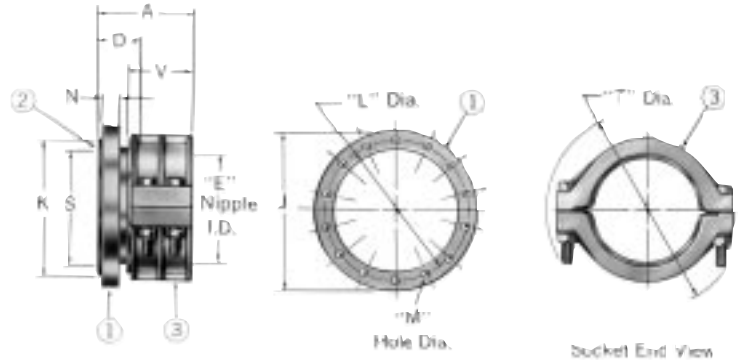

PART NUMBER	I.P.S. SIZE	NUMBER BOLT HOLES	A	D	E	J	K	L	M	N	S	T	V	WT. EA. (LBS.)
FC7750-8080-188	5	10	6.75	2.64	4.40	9.06	6.37	7.81	.69	1.08	5.32	11.44	4.75	45.0
FC7750-9696-188	6	12	6.75	2.64	5.40	10.12	7.37	8.88	.69	1.20	6.36	11.98	4.75	58.7
FC7750-0808-188	8	14	6.75	2.64	7.40	12.38	9.82	11.06	.69	1.33	8.32	13.89	4.75	80.1
FC7750-1010-188	10	15	7.01	2.89	9.40	15.00	12.00	13.44	.81	1.45	10.38	16.48	4.75	108.5
FC7750-1212-188	12	18	8.49	3.24	11.40	17.04	14.50	16.06	.81	1.52	12.32	17.04	6.00	
FC7781-8080-188	5	8	6.75	2.64	4.40	10.00	6.37	8.50	.88	1.06	5.32	11.44	4.75	40.4
FC7781-9696-188	6	8	6.75	2.64	5.40	11.00	7.37	9.50	.88	1.19	6.36	11.98	4.75	53.4
FC7781-0808-188	8	8	6.75	2.64	7.40	13.50	9.82	11.75	.88	1.31	8.32	13.89	4.75	70.5
FC7781-1010-188	10	12	7.01	2.89	9.40	16.00	12.00	14.25	1.00	1.44	10.38	16.48	4.75	95.0

COMPONENTS	REQ'D. PER ASS'Y.	PART NUMBER	SIZE				MATERIAL	MATERIAL SPECIFICATION	
			BASE NO.	8080	9696	0808			1010
① Swivel Flange	1	188-74045-188-74021-*		5-80	6-96	8-8	10-10	Alum. Bronze	C95800 or C95400
② Nipple	1	FC2463-		8080-188	9696-188	0808-188	1010-188	Alum. Bronze	C95800
③ Socket Assembly	1	FC2457-		80-188	96-188	08-188	10-188	see below	see below
Socket Segment	2	FC2457-1-		80-188	96-188	08-188	10-188	Alum. Bronze	C95800
Bolt	4	FF9411-		10-88	10-88	12-88	12-100	Monel	QQ-N-286
Nut	4	FF9033-		10-4	10-4	12-4	12-4	Monel	QQ-N-281
Washer	4	FF9412-		1001-4	1001-4	1201-4	1201-4	Monel	Commercial

\*Used with FC7781-188, 150 PSI A.N.S.I. Flange.

\*\*Use Part No. FC7781-Size-188 for 150 PSI A.N.S.I. Commercial flange fitting.

All dimensions in inches.

Dimensional information is for reference only.

Variations from these dimensions, on actual parts, may occur as the result of engineering revisions.

# Hose Fittings

## Large Bore

**Mates with 150 lb. A.N.S.I.  
Commercial flange B16.5  
FC7781-410**

for use with Hose 2580

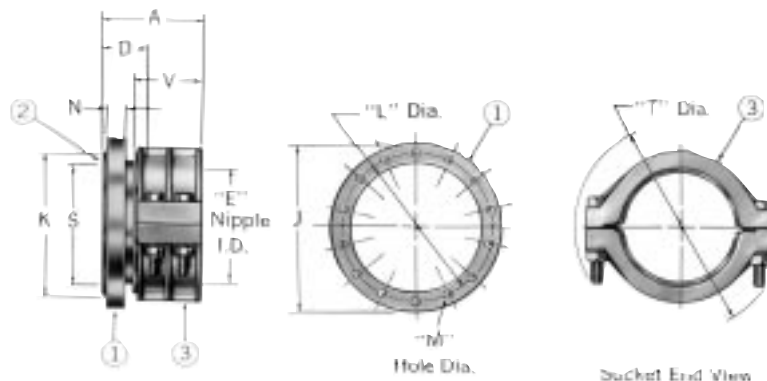

PART NUMBER	I.P.S. SIZE	NUMBER BOLT HOLES	A	D	E	J	K	L	M	N	S	T	V	WT. EA. (LBS.)
FC7781-9696-410	6	8	6.75	2.64	5.40	11.00	7.37	9.50	.88	1.19	6.36	11.98	4.75	54.2
FC7781-0808-410	8	8	6.75	2.64	7.40	13.50	9.82	11.75	.88	1.31	8.32	13.89	4.75	71.5
FC7781-1010-410	10	12	7.01	2.89	9.40	16.00	12.00	14.25	1.00	1.44	10.38	16.48	4.75	96.4

COMPONENTS	REQ'D. PER ASS'Y.	PART NUMBER				MATERIAL	MATERIAL SPECIFICATION
		BASE NO.	9696	0808	1010		
① Swivel Flange	1	407-74021	6-96	8-8	10-10	Stainless Steel	316
② Nipple	1	FC2463-	9696-407	0808-407	1010-407	Stainless Steel	316
③ Socket Assembly	1	FC2457-	96-188	08-188	10-188	see below	see below
Socket Segment	2	FC2457-1-	96-188	08-188	10-188	Alum. Bronze	C95800
Bolt	4	FF9411-	10-88	12-88	12-100	Monel	QQ-N-286
Nut	4	FF9033-	10-4	12-4	12-4	Monel	QQ-N-281
Washer	4	FF9412-	1001-4	1201-4	1201-4	Monel	QQ-N-281

All dimensions in inches.

Dimensional information is for reference only.

Variations from these dimensions, on actual parts, may occur as the result of engineering revisions.

# Hose Fittings

## Large Bore

**Mates with MIL-F-20042  
150/400 lb. flange\*\* 90°  
FC7751-188  
MIL-F-24787/1, Group IX,  
Type FL, Class II**

**Mates with 150 lb. A.N.S.I.  
Commercial flange B16.5\*\* 90°  
FC7780-188  
MIL-F-24787/1, Group IX,  
Type FL, Class V**

for use with Hose 2580

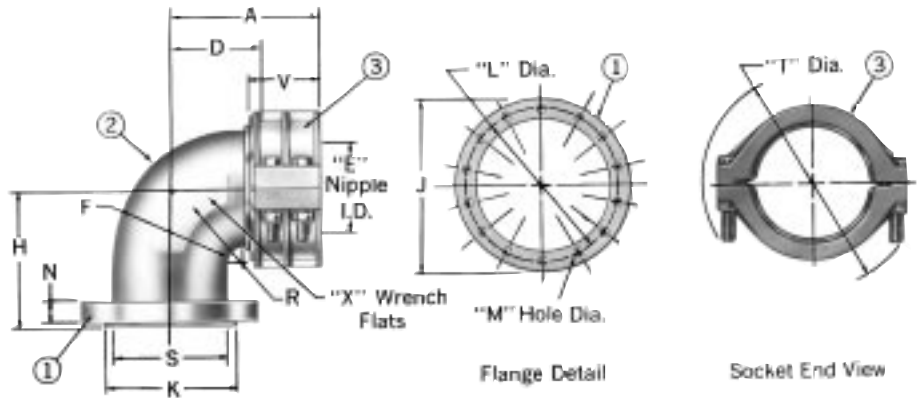

PART NUMBER	I.P.S. SIZE	NUMBER BOLT HOLES	A	D	E	F MAX	H	J	K	L	M	N	R	S	T	V	X	WT. EA. (LBS.)
FC7751-8080-188	5	10	8.64	4.52	4.40	4.96	6.81	9.06	6.37	7.81	.69	1.08	3.50	5.32	11.44	4.75	4.92	55.0
FC7751-9696-188	6	12	9.14	5.02	5.40	6.01	7.31	10.12	7.37	8.88	.69	1.20	4.00	6.36	11.98	4.75	6.01	71.1
FC7751-0808-188	8	14	10.34	6.22	7.40	8.04	8.81	12.38	9.82	11.06	.69	1.33	5.00	8.32	13.89	4.75	8.04	102.6
FC7751-1010-188	10	15	11.89	7.77	9.40	10.15	9.70	15.00	12.00	13.44	.81	1.45	6.38	10.38	16.48	4.75	10.15	147.1
FC7751-1212-188	12	18	14.24	9.00	11.40	12.15	10.70	17.50	14.50	16.06	.81	1.52	7.38	12.32	17.04	6.00	12.15	
FC7780-8080-188	5	8	8.64	4.52	4.40	4.96	6.81	10.00	6.37	8.50	.88	1.06	3.50	5.32	11.44	4.75	4.92	50.4
FC7780-9696-188	6	8	9.14	5.02	5.40	6.01	7.31	11.00	7.37	9.50	.88	1.19	4.00	6.36	11.98	4.75	6.01	65.8
FC7780-0808-188	8	8	10.34	6.22	7.40	8.04	8.81	13.50	9.82	11.75	.88	1.31	5.00	8.32	13.89	4.75	8.04	93.1
FC7780-1010-188	10	12	11.89	7.77	9.40	10.15	9.70	16.00	12.00	14.25	1.00	1.44	6.38	10.38	16.48	4.75	10.15	134.0
FC7780-1212-188	12	12	14.24	9.00	11.40	12.15	10.70	17.62	14.50	17.00	1.00	1.48	7.38	12.32	17.04	6.00	12.15	

COMPONENTS	REQ'D. PER ASS'Y.	PART NUMBER	SIZE					MATERIAL	MATERIAL SPECIFICATION	
			BASE NO.	8080	9696	0808	1010			1212
① Swivel Flange	1	188-74045- *188-74021-		5-80	6-96	8-8	10-10	12-12	Alum. Bronze	C95800 or C95400
② Nipple	1	FC2464-		8080-188	9696-188	0808-188	1010-188	1212-188	Alum. Bronze	C95800
③ Socket Assembly	1	FC2457-		80-188	96-188	08-188	10-188	12-188	see below	see below
Socket Segment	2	FC2457-1-		80-188	96-188	08-188	10-188	12-188	Alum. Bronze	C95800
Bolt	4	FF9411-		10-88	10-88	12-88	12-100	12-48	Monel	QQ-N-286
Nut	4	FF9033-		10-4	10-4	12-4	12-4	12-4	Monel	QQ-N-281
Washer	4	FF9412-		1001-4	1001-4	1201-4	1201-4	1201-4	Monel	Comm.

\*\*Use Part No. FC7780-Size-189 for 150 PSI A.N.S.I. Commercial flange fitting.

\*Used with FC7780-189, 150 PSI A.N.S.I. flange.

All dimensions in inches.

Dimensional information is for reference only.

Variations from these dimensions, on actual parts, may occur as the result of engineering revisions.

# Hose Fittings

## Large Bore

### Male split clamp

### FC7755-188

### MIL-F-24787/4, Group IX, Type E

for use with Hose 2580

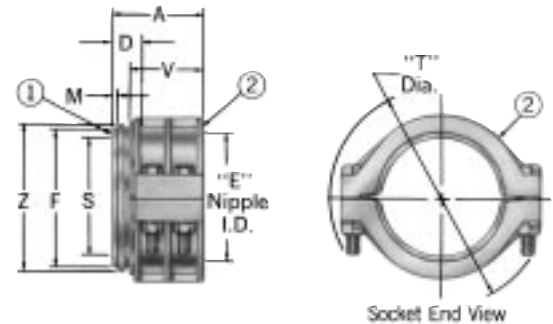

PART NUMBER	I.P.S. SIZE	A	D	E	F	M	S	T	V	Z	WT. EA. (LBS.)
FC7755-8080-188	5	6.22	2.10	4.40	5.62	.40	5.30	11.44	4.75	6.63	36.7
FC7755-9696-188	6	6.58	2.46	5.40	6.75	.45	6.38	11.98	4.75	7.57	45.4
FC7755-0808-188	8	6.80	2.68	7.40	9.00	.82	8.41	13.89	4.75	9.97	63.4
FC7755-1010-188	10	6.84	2.72	9.40	11.00	.86	10.53	16.48	4.75	12.06	77.0
FC7755-1212-188	12	8.16	2.91	11.40	12.00	.88	11.40	17.04	6.00	13.38	119.0

COMPONENTS	REQ'D. PER ASS'Y.	PART NUMBER	SIZE					MATERIAL	MATERIAL SPECIFICATION
			BASE NO.	8080	9696	0808	1010		
① Nipple	1	FC2468-	8080-188	9696-188	0808-188	1010-188	1212-188	Alum. Bronze	C95800
② Socket Assembly	1	FC2457-	80-188	96-188	08-188	10-188	12-188	see below	see below
Socket Segment	2	FC2457-1-	80-188	96-188	08-188	10-188	12-188	Alum. Bronze	C95800
Bolt	4	FF9411-	10-88	10-88	12-88	12-100	12-48	Monel	QQ-N-286
Nut	4	FF9033-	10-4	10-4	12-4	12-4	12-4	Monel	QQ-N-281
Washer	4	FF9412-	1001-4	1001-4	1201-4	1201-4	1201-4	Monel	Commercial

For Sil-Braze Type Tailpiece Assembly, see page 123.

For Split Clamp Assembly, see page 125. All dimensions in inches.

Dimensional information is for reference only.

Variations from these dimensions, on actual parts, may occur as the result of engineering revisions.

# Hose Fittings

## Large Bore

### Male split clamp 90°

### FC7752-188

### MILF- 24787/4, Group IX, Type EL

for use with Hose 2580

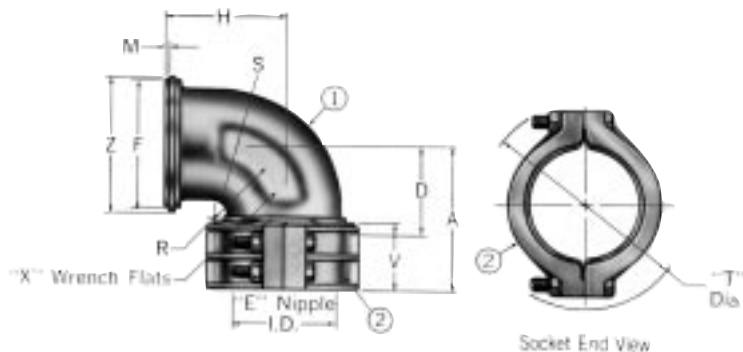

PART NUMBER	I.P.S. SIZE	A	D	E	F	H	M	R	S MAX.	T	V	X	Z	WT. EA. (LBS.)
FC7752-8080-188	5	8.64	4.52	4.40	5.62	6.81	.40	3.50	4.96	11.44	4.75	4.92	6.63	46.0
FC7752-9696-188	6	9.14	5.02	5.40	6.75	7.31	.45	4.00	6.01	11.98	4.75	6.01	7.57	57.8
FC7752-1010-188	10	11.89	7.77	9.40	11.00	9.70	.86	6.38	10.15	16.48	4.75	10.15	12.06	115.0

COMPONENTS	REQ'D. PER ASS'Y.	PART NUMBER			MATERIAL	MATERIAL SPECIFICATION	
		BASE NO.	SIZE				
DESCRIPTION			8080	9696	0808		
① Nipple	1	FC2465-	8080-188	9696-188	0808-188	Alum. Bronze	C95800
② Socket Assembly	1	FC2457-	80-188	96-188	10-188	see below	see below
Socket Segment	2	FC2457-1-	80-188	96-188	10-188	Alum. Bronze	C95800
Bolt	4	FF9411-	10-88	10-88	12-100	Monel	QQ-N-286
Nut	4	FF9033-	10-4	10-4	12-4	Monel	QQ-N-281
Washer	4	FF9412-	1001-4	1001-4	1201-4	Monel	Commercial

For Sil-Braze Type Tailpiece Assembly, see page 123.

For Split Clamp Assembly, see page 125. All dimensions in inches.

Dimensional information is for reference only.

Variations from these dimensions, on actual parts, may occur as the result of engineering revisions.

# Hose Fittings

## Large Bore

### Female split clamp 90° FC7753-188 MIL-F-24787/6, Group IX, Type U\*

for use with Hose 2580

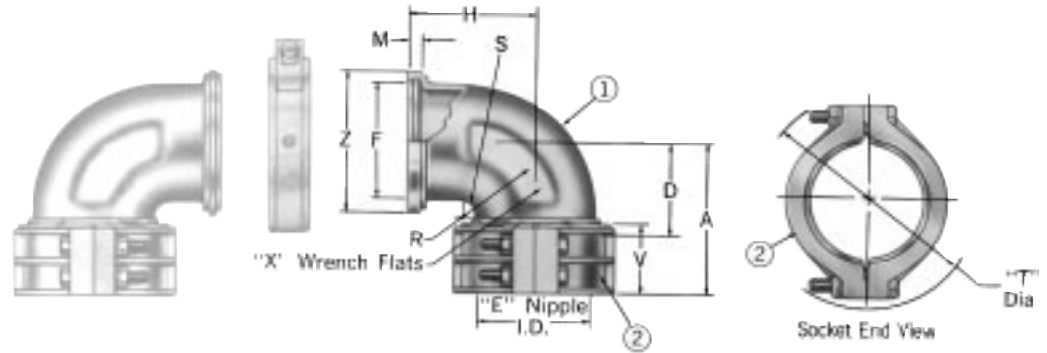

PART NUMBER	I.P.S. SIZE	A	D	E	F	H	M	R	S MAX.	T	V	X	Z	WT. EA. (LBS.)
FC7753-8080-188	5	8.64	4.52	4.40	5.64	6.81	.42	3.50	4.96	11.44	4.75	4.92	6.63	45.1
FC7753-9696-188	6	9.14	5.02	5.40	6.76	7.31	.47	4.00	6.01	11.98	4.75	6.01	7.57	57.8
FC7753-0808-188	8	10.34	6.22	7.40	9.01	8.81	.84	5.00	8.04	13.89	4.75	8.04	9.97	85.9
FC7753-1010-188	10	11.89	7.77	9.40	11.01	9.70	.88	6.38	10.15	16.48	4.75	10.15	12.06	120.0
FC7753-1212-188	12	14.24	9.00	11.40	12.01	10.70	.90	7.38	12.15	17.04	6.00	12.15	13.38	

COMPONENTS	REQ'D. PER ASS'Y.	PART NUMBER	SIZE					MATERIAL	MATERIAL SPECIFICATION
			BASE NO.	8080	9696	0808	1010		
① Nipple	1	FC2466-	8080-188	9696-188	0808-188	1010-188	1212-188	Alum. Bronze	C95800
② Socket Assembly	1	FC2457-	80-188	96-188	08-188	10-188	12-188	see below	see below
Socket Segment	2	FC2457-1-	80-188	96-188	08-188	10-188	12-188	Alum. Bronze	C95800
Bolt	4	FF9411-	10-88	10-88	12-88	12-100	12-48	Monel	QQ-N-286
Nut	4	FF9033-	10-4	10-4	12-4	12-4	12-4	Monel	QQ-N-281
Washer	4	FF9412-	1001-4	1001-4	1201-4	1201-4	1201-4	Monel	Commercial
O-Ring (not supplied – order separately)	1	22020-	255	261	447	451		Buna-N	

\*To meet military specifications, must include FC7752-size Slip Clamp Assembly 900750-size. See page 125.  
All dimensions in inches.

Dimensional information is for reference only.

Variations from these dimensions, on actual parts, may occur as the result of engineering revisions.

# Hose Fittings

## Large Bore

### Dogleg 90° FC7754-188 MIL-F-24787/5, Group IX, Type D

for use with Hose 2580

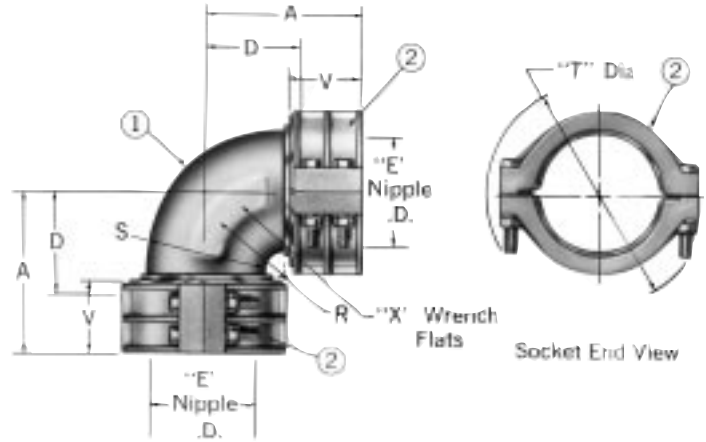

PART NUMBER	A	D	E	R	S MAX.	T	V	X	WT. EA. (LBS.)
FC7754-8080-188	8.64	4.52	4.40	3.50	4.96	11.44	4.75	4.92	69.9
FC7754-9696-188	9.14	5.02	5.40	4.00	6.01	11.98	4.75	6.01	86.9
FC7754-0808-188	10.34	6.22	7.40	5.00	8.04	13.89	4.75	8.04	122.0
FC7754-1010-188	11.89	7.77	9.40	6.38	10.15	16.48	4.75	10.15	171.0
FC7754-1212-188	14.24	9.00	11.40	7.38	12.15	17.04	6.00	12.15	

COMPONENTS DESCRIPTION	REQ'D. PER ASS'Y.	PART NUMBER BASE NO.	SIZE					MATERIAL	MATERIAL SPECIFICATION
			8080	9696	0808	1010	1212		
① Nipple	1	FC2467-	8080- 188	9696- 188	0808- 188	1010- 188	1212- 188	Alum. Bronze	C95800
② Socket Assembly	2	FC2457-	80- 188	96- 188	08- 188	10- 188	12- 188	see below	see below
Socket Segment	4	FC2457-1-	80- 188	96- 188	08- 188	10- 188	12- 188	Alum. Bronze	C95800
Bolt	8	FF9411-	10-88	10-88	12-88	12-100	12-48	Monel	QQ-N-286
Nut	8	FF9033-	10-4	10-4	12-4	12-4	12-4	Monel	QQ-N-281
Washer	8	FF9412-	1001-4	1001-4	1201-4	1201-4	1201-4	Monel	Commercial

All dimensions in inches.

Dimensional information is for reference only.

Variations from these dimensions, on actual parts, may occur as the result of engineering revisions.

# Hose Fittings

## Large Bore

### Dogleg 90° FC7754-410 MIL-F-24787/5, Group IX, Type D

for use with Hose 2580

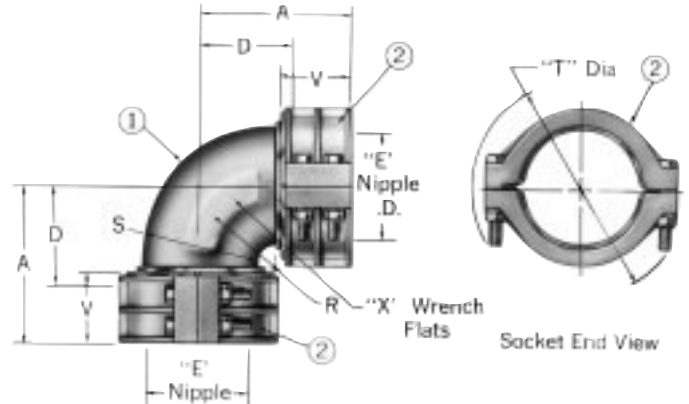

PART NUMBER	A	D	E	R	S MAX.	T	V	X	WT. EA. (LBS.)
FC7754-8080-410	8.64	4.52	4.40	3.50	4.96	11.44	4.75	4.92	69.9
FC7754-9696-410	9.14	5.02	5.40	4.00	6.01	11.98	4.75	6.01	86.9
FC7754-0808-410	10.34	6.22	7.40	5.00	8.04	13.89	4.75	8.04	122.0
FC7754-1010-410	11.89	7.77	9.40	6.38	10.15	16.48	4.75	10.15	171.0
FC7754-1212-410	14.24	9.00	11.40	7.38	12.15	17.04	6.00	12.15	

COMPONENTS DESCRIPTION	REQ'D. PER ASS'Y.	PART NUMBER			MATERIAL	MATERIAL SPECIFICATION	
		BASE NO.	9696	0808			1010
① Nipple	1	FC2467-	9696 407	0808 407	1010 407	Stainless Steel	316
② Socket Assembly	4	FC2457-	96- 188	08- 188	10- 188	see below	
Socket Segment	4	FC2457-1	96- 188	08- 188	10- 188	Alum. Bronze	C95800
Bolt	8	FF9411-	10-88	12-88	12-100	Monel	QQ-N-281
Nut	8	FF9033-	10-4	12-4	12-4	Monel	QQ-N-281
Washer	8	FF9412-	1001- 4	1201- 4	1201- 4	Monel	QQ-N-281

All dimensions in inches.

Dimensional information is for reference only.

Variations from these dimensions, on actual parts, may occur as the result of engineering revisions.

# Hose Fittings

## Large Bore

**Mates with MIL-F-20042  
150/400 lb. flange  
FC9527-188  
MIL-F-24787/1, Group X,  
Type F, Class II**

for use with Hose FC132

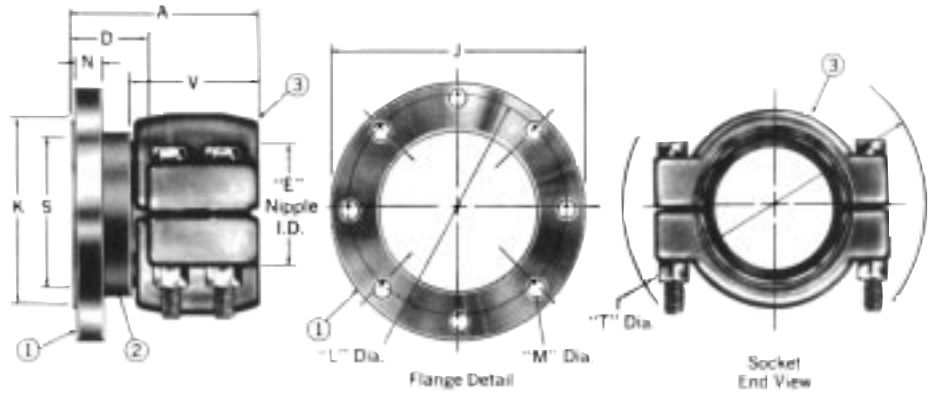

PART NUMBER	I.P.S. SIZE	NUMBER BOLT HOLES	A	D	E	J	K	L	M	N	S	T	V	WT. EA. (LBS.)
FC9527-3240-188	2	6	4.40	1.96	2.06	5.56	3.28	4.44	.56	.83	2.24	6.70	3.00	14.6
FC9527-4048-188	2½	6	4.86	1.96	2.51	6.12	3.78	5.00	.56	.95	2.71	7.65	3.50	17.6
FC9527-4848-188	3	8	4.86	1.96	2.51	6.62	4.50	5.50	.56	.95	3.31	7.65	3.50	17.9
FC9527-5664-188	3½	8	5.28	2.37	3.50	7.19	5.22	6.06	.56	1.02	3.81	8.91	3.59	25.9
FC9527-6464-188	4	8	5.28	2.37	3.50	7.69	5.22	6.56	.56	1.02	4.28	8.91	3.59	27.8

COMPONENTS	REQ'D. PER ASS'Y.	PART NUMBER	SIZE					MATERIAL	MATERIAL SPECIFICATION
			BASE NO.	3240	4048	4848	5664		
① Swivel Flange	1	188-74045-	2-40	2½-48	3-48	3½-64	4-64	Alum. Bronze	C95800 or C95400
② Nipple	1	FC3478-	3240-188	4048-188	4848-188	5664-188	6464-188	Alum. Bronze	C95800
③ Socket Assembly	1	FC3477-	40-188	48-188	48-188	64-188	64-188	see below	see below
Socket Segment	2	FC3476-	40-188	48-188	48-188	64-188	64-188	Bronze	C95800
Bolt	4	FF9142-	0856-4	0964-4	0964-4	1072-4	1072-4	Monel	QQ-N-286
Nut	4	4-222048-	8	9	9	10	10	Monel	QQ-N-281 or QQ-N-286

All dimensions in inches.

Dimensional information is for reference only.

Variations from these dimensions, on actual parts, may occur as the result of engineering revisions.

# Hose Fittings

## Large Bore

**Mates with MIL-F-20042  
150/400 lb. flange 90°  
FC9637-188  
MIL-F-24787/1, Group X,  
Type FL, Class II**  
for use with Hose FC132

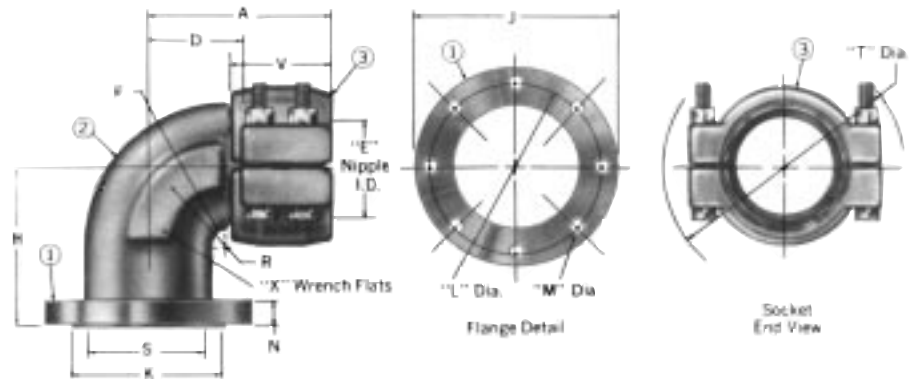

PART NUMBER	I.P.S. SIZE	NUMBER BOLT HOLES	A	D	E	F MAX	H	J	K	L	M	N	R	S	T	V	X	WT. EA. (LBS.)
FC9637-3240-188	2	6	4.92	2.50	2.06	3.00	4.00	5.56	3.28	4.44	.56	.83	1.88	2.24	6.70	3.00	2.75	15.5
FC9637-4040-188	2½	6	4.92	2.50	2.06	3.00	4.00	6.12	3.28	5.00	.56	.95	2.09	2.24	6.70	3.00	2.75	19.8
FC9637-4048-188	2½	6	5.65	2.75	2.51	3.31	4.50	6.12	3.78	5.00	.56	.95	2.09	2.71	7.65	3.50	3.19	19.8
FC9637-4848-188	3	8	5.65	2.75	2.51	3.50	4.50	6.62	4.50	5.50	.56	.95	2.09	3.31	7.65	3.50	3.19	20.3
FC9637-5664-188	3½	8	6.48	3.57	3.50	4.75	5.62	7.19	5.22	6.06	.56	1.02	2.81	3.81	8.91	3.59	4.50	31.5
FC9637-6464-188	4	8	6.48	3.57	3.50	4.75	5.62	7.69	5.22	6.56	.56	1.02	2.81	4.28	8.91	3.59	4.50	33.4

COMPONENTS DESCRIPTION	REQ'D. PER ASS'Y.	PART NUMBER BASE NO.	PART NUMBER → SIZE →							MATERIAL	MATERIAL SPECIFICATION
			3240	4040	4048	4848	5664	6464			
① Swivel Flange	1	188-74045-	2-40	2½-40	2½-48	3-48	3½-64	4-64	Alum. Bronze	C95800 or C95400	
② Nipple	1	FC3558-	3240 -188	4040 -188	4048 -188	4848 -188	5664 -188	6464 -188	Alum. Bronze	C95800	
③ Socket Assembly	1	FC3477-	40- 188	40- 188	48- 188	48- 188	64- 188	64- 188	see below	see below	
Socket Segment	2	FC3476-	40- 188	40- 188	48- 188	48- 188	64- 188	64- 188	Alum. Bronze	C95800	
Bolt	4	FF9142-	0856-4	0856-4	0964-4	0964-4	1072-4	1072-4	Monel	QQ-N-286	
Nut	4	4-222048-	8	8	9	9	10	10	Monel	QQ-N-281 or QQ-N-286	

All dimensions in inches.

Dimensional information is for reference only.

Variations from these dimensions, on actual parts, may occur as the result of engineering revisions.

# Hose Fittings

## Large Bore

Mates with MIL-F-20042  
flange 400 lb.  
**FC9568-188**  
MIL-F-24787/1, Group X,  
Type F, Class I

for use with Hose FC132

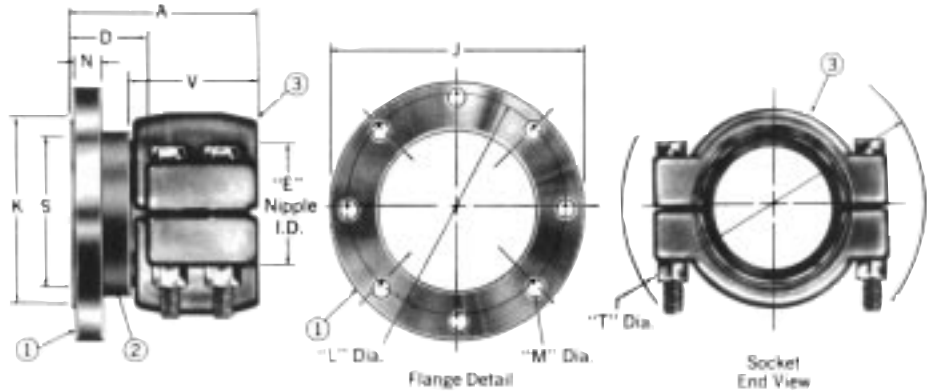

PART NUMBER	I.P.S. SIZE	NUMBER BOLT HOLES	A	D	E	J	K	L	M	N	S	T	V	WT. EA. (LBS.)
FC9568-3240-188	2	7	4.40	1.96	2.06	6.50	3.28	5.19	.69	.81	2.24	6.70	3.00	15.2
FC9568-4048-188	2½	8	4.86	1.96	2.51	7.56	3.78	6.00	.81	.94	2.71	7.65	3.50	22.4
FC9568-4848-188	3	8	4.86	1.96	2.51	8.12	4.50	6.56	.81	.94	3.31	7.65	3.50	23.2
FC9568-5664-188	3½	9	5.28	2.37	3.50	8.69	5.22	7.12	.81	1.00	3.81	8.91	3.59	30.9
FC9568-6464-188	4	9	5.28	2.37	3.50	9.25	5.22	7.69	.81	1.00	4.28	8.91	3.59	33.7

COMPONENTS	REQ'D. PER ASS'Y.	PART NUMBER	SIZE					MATERIAL	MATERIAL SPECIFICATION
			BASE NO.	3240	4048	4848	5664		
① Swivel Flange	1	188-74048-	2-40	2½-48	3-48	3½-64	4-64	Alum. Bronze	C95800 or C95400
② Nipple	1	FC3478-	3240-188	4048-188	4848-188	5664-188	6464-188	Alum. Bronze	C95800
③ Socket Assembly	1	FC3477-	40-188	48-188	48-188	64-188	64-188	see below	see below
Socket Segment	2	FC3476-	40-188	48-188	48-188	64-188	64-188	Alum. Bronze	C95800
Bolt	4	FF9142-	0856-4	0964-4	0964-4	1072-4	1072-4	Monel	QQ-N-286
Nut	4	4-222048-	8	9	9	10	10	Monel	QQ-N-281 or QQ-N-286

All dimensions in inches.

Dimensional information is for reference only.

Variations from these dimensions, on actual parts, may occur as the result of engineering revisions.

# Hose Fittings

## Large Bore

**Mates with MIL-F-20042  
flange 90° 400 lb.  
FC9638-188  
MIL-F-24787/1, Group X,  
Type FL, Class I**

for use with Hose FC132

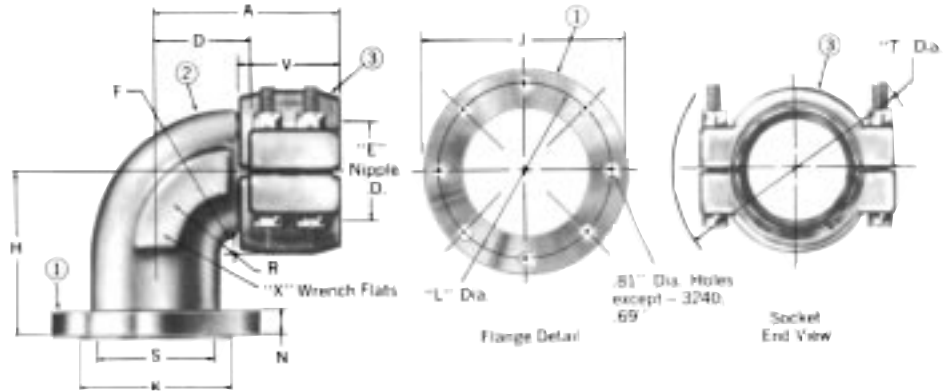

PART NUMBER	I.P.S. SIZE	NUMBER BOLT HOLES	A	D	E	F MAX.	H	J	K	L	N	R	S	T	V	X	WT. EA. (LBS.)
FC9638-3240-188	2	7	4.92	2.50	2.06	3.00	4.00	6.50	3.28	5.19	.83	1.88	2.24	6.70	3.00	2.75	17.1
FC9638-4048-188	2½	8	5.65	2.75	2.51	3.31	4.50	7.56	3.78	6.00	.95	2.09	2.71	7.65	3.50	3.19	23.7
FC9638-4848-188	3	8	5.65	2.75	2.51	3.50	4.50	8.12	4.50	6.56	.95	2.09	3.31	7.65	3.50	3.19	24.8
FC9638-6464-188	4	9	6.48	3.57	3.50	4.75	5.62	9.25	5.22	7.69	1.02	2.81	4.28	8.91	3.59	4.50	39.3

COMPONENTS	REQ'D. PER ASS'Y.	PART NUMBER	SIZE				MATERIAL	MATERIAL SPECIFICATION	
			BASE NO.	3240	4048	4848			6464
① Swivel Flange	1	188-74048-		2-40	2½-48	3-48	4-64	Alum. Bronze	C95800 or C95400
② Nipple	1	FC3558-		3240-188	4048-188	4848-188	6464-188	Alum. Bronze	C95800
③ Socket Assembly	1	FC3477-		40-188	48-188	48-188	64-188	see below	see below
Socket Segment	2	FC3476-		40-188	48-188	48-188	64-188	Alum. Bronze	C95800
Bolt	4	FF9142-		0856-4	0964-4	0964-4	1072-4	Monel	QQ-N-286
Nut	4	4-222048-		8	9	9	10	Monel	QQ-N-281 or QQ-N-286

All dimensions in inches.

Dimensional information is for reference only.

Variations from these dimensions, on actual parts, may occur as the result of engineering revisions.

# Hose Fittings

## Large Bore

### Male split clamp type

### FC9635-188

### MIL-F-24787/4, Group X, Type E

for use with Hose FC132

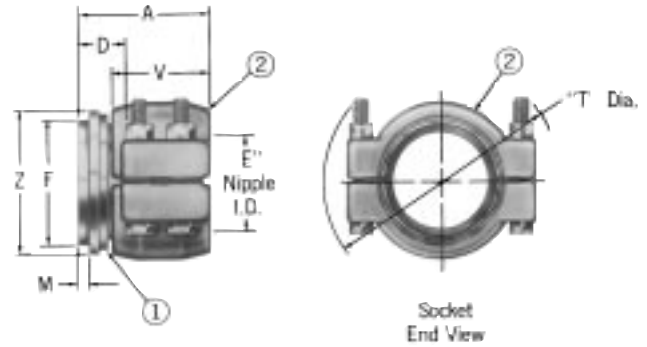

PART NUMBER	I.P.S. SIZE	A	D	E	F	M	T	V	Z	WT. EA. (LBS.)
FC9635-3240-188	2	4.02	1.59	2.06	2.50	.33	6.70	3.00	3.24	8.8
FC9635-4048-188	2½	4.59	1.69	2.51	3.00	.33	7.65	3.50	3.74	12.5
FC9635-4848-188	3	4.59	1.69	2.51	3.62	.33	7.65	3.50	4.37	13.0
FC9365-5664-188	3½	4.64	1.73	3.50	4.12	.33	8.91	3.59	4.93	19.5
FC9665-6464-188	4	4.75	1.84	3.50	4.62	.40	8.91	3.5	5.43	20.5

COMPONENTS DESCRIPTION	REQ'D. PER ASS'Y.	PART NUMBER						MATERIAL	MATERIAL SPECIFICATION
		BASE NO.	SIZE	3240	4048	4848	5664		
① Nipple	1	FC3555-	3240-188	4048-188	4848-188	5664-188	6464-188	Alum. Bronze	C95800
② Socket Assembly	1	FC3477-	40-188	48-188	48-188	64-188	64-188	see below	see below
Socket Segment	2	FC3476-	40-188	48-188	48-188	64-188	64-188	Alum. Bronze	C95800
Bolt	4	FF9142-	0856-4	0964-4	0964-4	1072-4	1072-4	Monel	QQ-N-286
Nut	4	4-222048-	8	9	9	10	10	Monel	QQ-N-281 or QQ-N-286

For Sil-Braze Type Tailpiece Assembly, see page 123.

For Split Clamp Assembly, see page 125.

All dimensions in inches.

Dimensional information is for reference only.

Variations from these dimensions, on actual parts, may occur as the result of engineering revisions.

# Hose Fittings

## Large Bore

### Male split clamp type 90° FC9636-188 MIL-F-24787/4, Group X, Type EL

for use with Hose FC132

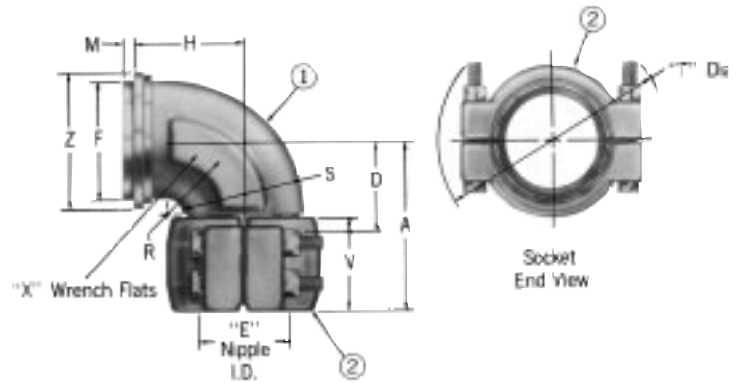

PART NUMBER	I.P.S. SIZE	A	D	E	F	H	M	R	S MAX.	T	V	X	Z	WT. EA. (LBS.)
FC9636-3240-188	2	4.92	2.50	2.06	2.50	3.09	.33	1.88	3.00	6.70	3.00	2.75	3.24	9.5
FC9636-4048-188	2½	5.75	2.85	2.51	3.00	3.17	.33	2.09	3.50	7.65	3.50	3.19	3.74	12.6
FC9636-4848-188	3	6.15	3.25	2.51	3.62	3.20	.33	2.09	3.50	7.65	3.50	3.19	4.37	15.7
FC9636-5664-188	3½	6.48	3.57	3.50	4.12	4.04	.33	2.81	4.75	8.91	3.59	4.50	4.93	25.1
FC9636-6464-188	4	6.48	3.57	3.50	4.62	4.06	.40	2.81	4.75	8.91	3.59	4.50	5.43	26.0

COMPONENTS DESCRIPTION	REQ'D. PER ASS'Y.	PART NUMBER BASE NO.	SIZE					MATERIAL	MATERIAL SPECIFICATION
			3240	4048	4848	5664	6464		
① Nipple	1	FC3557-	3240-188	4048-188	4848-188	5664-188	6464-188	Alum. Bronze	C95800
② Socket Assembly	1	FC3477-	40-188	48-188	48-188	64-188	64-188	see below	see below
Socket Segment	2	FC3476-	40-188	48-188	48-188	64-188	64-188	Alum. Bronze	C95800
Bolt	4	FF9142-	0856-4	0964-4	0964-4	1072-4	1072-4	Monel	QQ-N-286
Nut	4	4-222048-	8	9	9	10	10	Monel	QQ-N-281 or QQ-N-286

For Sil-Braze Type Tailpiece Assembly, see page 123.

For Split Clamp Assembly, see page 125.

All dimensions in inches. Dimensional information is for reference only.

Variations from these dimensions, on actual parts, may occur as the result of engineering revisions.

# Hose Fittings

## Large Bore

### 90° Dogleg FC9528-188 MIL-F-24787/4, Group X, Type D

for use with Hose FC132

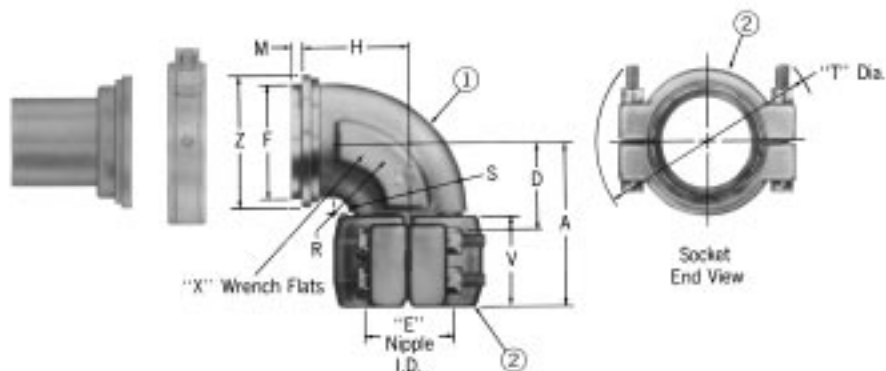

PART NUMBER	I.P.S. SIZE	A	D	E	R	S MAX.	T	V	Z	WT. EA. (LBS.)
FC9528-4040-188	2½	4.92	2.50	2.06	1.88	3.00	6.70	3.00	2.75	15.8
FC9528-4848-188	3	5.65	2.75	2.51	2.09	3.50	7.65	3.50	3.19	23.3
FC9528-6464-188	4	6.48	3.57	3.50	2.81	4.75	8.91	3.59	4.50	36.5

COMPONENTS	REQ'D. PER ASS'Y.	PART NUMBER			MATERIAL	MATERIAL SPECIFICATION	
		BASE NO.	4040	4848			6464
DESCRIPTION			SIZE				
① Nipple	1	FC3479-	4040-188	4848-188	6464-188	Alum. Bronze	C95800
② Socket Assembly	2	FC3477-	40-188	48-188	64-188	see below	see below
Socket Segment	4	FC3476-	40-188	48-188	64-188	Alum. Bronze	C95800
Bolt	8	FF9142-	0856-4	0964-4	1072-4	Monel	QQ-N-286
Nut	8	4-222048-	8	9	10	Monel	QQ-N-281 or QQ-N-286

All dimensions in inches.

Dimensional information is for reference only.

Variations from these dimensions, on actual parts, may occur as the result of engineering revisions.

# Hose Fittings

## Tailpiece

**Tailpiece Assembly**  
**FF5001-188, FF5002-188**  
**188-500063, 188-500189**  
**MIL-F-24787/4, Type TE**

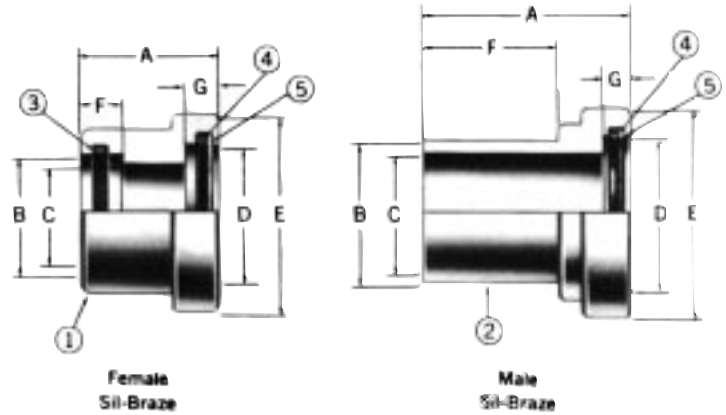

FEMALE TYPE PART NUMBER	I.P.S. SIZE	A	B	C	D	E	F**	G
*FF5001-20-188	1¼	1.48	1.66	1.46	1.76	2.43	.50	.35
*FF5001-24-188	1½	1.57	1.90	1.67	2.01	2.75	.62	.35
*FF5001-32-188	2	1.64	2.38	2.12	2.51	3.25	.66	.35
*FF5001-40-188	2½	1.86	2.88	2.59	3.01	3.75	.78	.35
188-500063-3	3	1.55	3.50	3.33	3.64	4.36	.83	.35
188-500063-3½	3½	1.59	4.00	3.81	4.14	4.93	.88	.35
188-500063-4	4	1.70	4.50	4.31	4.64	5.43	.91	.42
188-500063-5	5	1.80	5.57	5.30	5.64	6.63	1.00	.42
188-500063-6	6	1.95	6.63	6.38	6.76	7.57	1.11	.47

TYPE PART NUMBER	I.P.S. SIZE	A	B	C	D	E	F	G
*FF5002-20-188	1¼	1.95	1.66	1.41	1.76	2.43	1.12	.35
*FF5002-24-188	1½	2.07	1.90	1.62	2.01	2.74	1.25	.35
*FF5002-32-188	2	2.17	2.38	2.04	2.51	3.24	1.31	.35
*FF5002-40-188	2½	2.04	2.88	2.59	3.01	3.74	1.12	.35
188-500189-3	3	3.45	3.50	3.00	3.63	4.37	2.50	.35
188-500189-3½	3½	3.45	4.00	3.50	4.13	4.93	2.50	.35
188-500189-4	4	3.67	4.50	3.88	4.63	5.43	2.64	.42
188-500189-5	5	3.80	5.56	4.94	5.63	6.62	2.77	.42
188-500189-6	6	3.87	6.62	5.96	6.76	7.57	2.67	.47

\*These Sil-Braze tailpieces have been designed for ultrasonic testing, other sizes available upon request.

\*\*Minimum dimensions for 500063.

All dimensions in inches.

Dimensional information is for reference only. Variations from these dimensions, on actual parts, may occur as the result of engineering revisions.

COMPONENTS DESCRIPTION	REQ'D. PER ASS'Y.	PART NUMBER BASE NO.	PART NUMBER SIZE											MATERIAL	MATERIAL SPECIFICATION	
			20	24	32	40	3	3½	4	5	6	8	10			
① Tailpiece	1	188-72462-	1¼	1½	2	2½									Alum. Bronze	C95800 or C95400
① Tailpiece	1	188-72019-					3	3½	4	5	6	8	10		Alum. Bronze	C95800 or C95400
② Tailpiece	1	188-72463-	1¼	1½	2	2½									Alum. Bronze	C95800 or C95400
② Tailpiece	1	188-72039-					3	3½	4	5	6	8	10		Alum. Bronze	C95800 or C95400
③ Braze Ring	1	FF9003-	1¼-1	1½-1	2-1	2½-1	3-1	3½-1	4-1	5-1	6-1	8-1	10-1		Silver Alloy	QQ-B-654A BCu P-5
④ O-Ring	1	22020-	224	226	230	234	239	243	247	255	261	447	451		Buna-N	see page 124
⑤ Back-up Ring	1	22006-	2	4	8	12									Leather	see page 124

# Hose Fittings

## Tailpiece

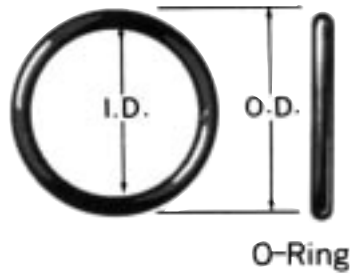

O-Ring

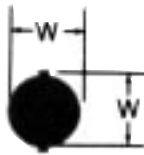

### O-Ring 22020

(Buna-N)

PART NUMBER	W.	O.D.	I.D.
22020-230	.12	2.75	2.50
22020-234	.12	3.25	3.00
22020-239	.12	3.88	3.62
22020-243	.12	4.38	4.12
22020-247	.12	4.88	4.62
22020-255	.14	5.88	5.62
22020-261	.14	7.00	6.75

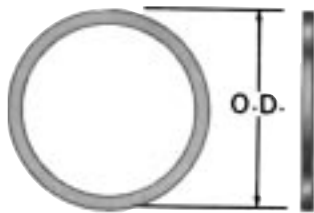

Back-up Ring

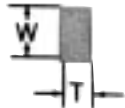

### Back-up Ring 22006

(Commercial grade leather)

PART NUMBER	W.	T.	O.D.	I.D.
22020-447	.28		9.50	9.00
22020-451	.28		11.50	11.00
22006-2	.12	.06	2.00	
22006-4	.12	.06	2.25	
22006-8	.12	.06	2.75	
22006-12	.12	.06	3.25	

# Hose Fittings

## Split Clamp

**Split clamp assembly  
900758  
MIL-F-24787/4, Type SC**

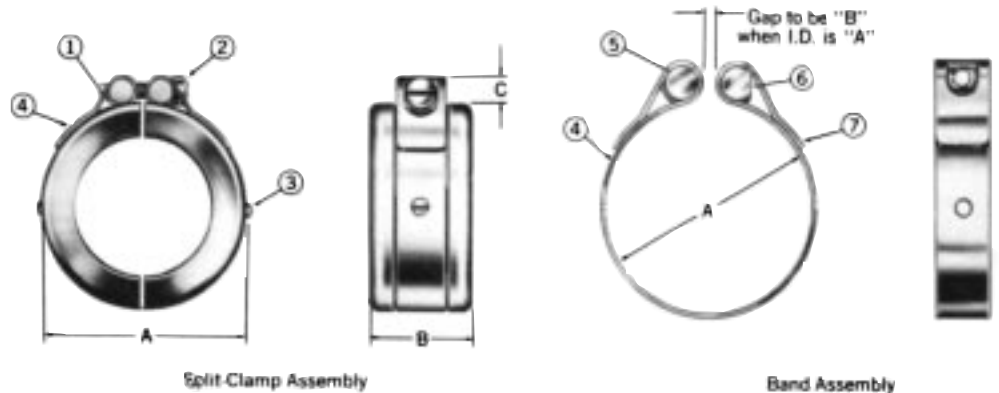

PART NUMBER	I.P.S. SIZE	A	B	C	WT. EA. (LBS.)
900758-1¼	1¼	3.00	1.31	.39	1.03
900758-1½	1½	3.31	1.31	.39	1.12
900758-2	2	4.00	1.38	.39	1.82
900758-2½	2½	4.42	1.44	.39	1.90
900758-3	3	5.19	1.50	.39	2.81
900758-3½	3½	5.56	1.50	.39	2.44
900758-4	4	6.12	1.62	.39	3.15
900758-5	5	7.31	1.62	.39	3.83
900758-6	6	8.25	1.94	.39	5.08
900758-8	8	10.78	2.38	.39	7.00
900758-10	10	12.88	2.38	.39	9.00
900758-12	12	14.28	2.10	.39	

COMPONENTS DESCRIPTION	REQ'D. PER ASS'Y.	PART NUMBER BASE NO.	PART NUMBER SIZE												MATERIAL	MATERIAL SPECIFICATION
			1¼	1½	2	2½	3	3½	4	5	6	8	10	12		
① Split Clamp	2	115-900757-	1¼	1½	2	2½	3	3½	4	5	6	8	10	12	Bronze	QQ-C-390, Alloy C95500 (as cast)
② Screw	1	FH9515	0420-14	0420-14	0420-14	0420-14	0420-14	0420-14	0420-14	0420-14	0420-14	0420-14	0420-14	0420-14	Bronze	QQ-C-591 Alloy 651 or 655
③ Screw	2 4	14-21002	1-6-4 1-6-4	1-6-4 1-6-4	1-6-4 1-6-4	1-6-4 1-6-4	1-6-4 1-6-4	1-6-4 1-6-4	1-6-4 1-6-4	1-6-4					Monel	QQ-C-591 Alloy 651 or 655
④ Band Assembly	1	900762-	15	17	18	19	21	22	23	26	27	28	29	30	Bronze & Monel	QQ-N-281 and QQ-C-951 Alloy 655

All dimensions in inches.

Dimensional information is for reference only.

Variations from these dimensions, on actual parts, may occur as the result of engineering revisions.

# Hose Fittings

## O-Rings

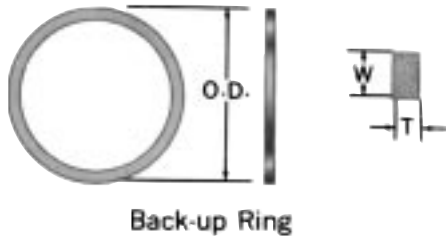
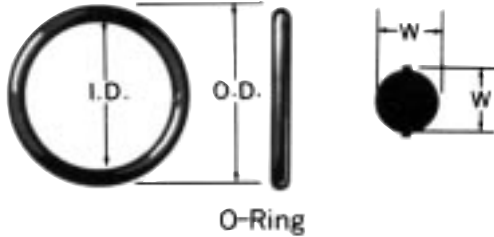

Leather Back-up ring 22006\*  
 22015 O-Ring (Butyl)  
 22020\* O-Ring (Buna-N)  
 22550 O-Ring (Buna-N)

PART NUMBER	W	T	O.D.	I.D.	WT. EA. (LBS.)
22006-8	.12	.06	2.75		.002
22006-12	.12	.06	3.25		.003
22015-11	.06		.44	.31	.002
22015-114	.09		.81	.62	.002
22015-210	.12		1.00	.75	.002
22015-212	.12		1.12	.88	.002
22015-214	.12		1.25	1.00	.002
22015-217	.12		1.44	1.19	.003
22015-222	.12		1.75	1.50	.003
22015-224	.12		2.00	1.75	.004
22015-227	.12		2.38	2.12	.004
22020-230	.12		2.75	2.50	.005
22020-234	.12		3.25	3.00	.007
22020-239	.12		3.88	3.62	.008
22020-243	.12		4.38	4.12	.009
22020-247	.12		4.88	4.62	.010
22020-255	.12		5.88	5.62	.012
22020-261	.12		7.00	6.75	0.16
22550-11	.06		.44	.31	.002
22550-114	.09		.81	.62	.002
22550-210	.12		1.00	.75	.002
22550-212	.12		1.12	.88	.002
22550-214	.12		1.25	1.00	.002
22550-217	.12		1.44	1.19	.003
22550-222	.12		1.75	1.50	.003
22550-224	.12		2.00	1.75	.004
22550-227	.12		2.38	2.12	.004

\*For other sizes, see page 124.

All dimensions in inches.

Dimensional information is for reference only. Variations from these dimensions, on actual parts, may occur as the result of engineering revisions.

# Hose Fittings

## PTFE

### Male pipe 190627-C

for use with Hose 2807

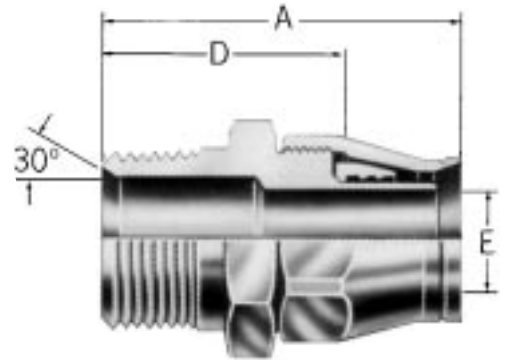

PART NUMBER	O.D. TUBE SIZE	THREAD	A	D	E	WT. EA. (LBS.)
190627-2-4C	¼	½-27	1.36	.89	.16	
190627-4-5C	⅜	¼-18	1.60	1.07	.23	.08
190627-6-6C	½	⅜-18	1.67	1.13	.28	
190627-8-8C	¾	½-14	2.05	1.41	.38	
190627-8-10C	¾	½-14	2.13	1.46	.47	.25
190627-12-12C	1	¾-14	2.28	1.61	.59	.32
190627-16-16C	1	1-11½	2.48	1.86	.83	.48

COMPONENTS	REQ'D. PER ASS'Y.	PART NUMBER BASE NO.	SIZE							MATERIAL	MATERIAL SPECIFICATION
			2-4	4-5	6-6	8-8	8-10	12-12	16-16		
① Nipple	1	1267-	2-4C	4-5C	6-6C	8-8C	8-10C	12-12C	16-16C	Stainless Steel	303
② Sleeve	1	900568-	4C	5C	6C	8C	10C	12C	16C	Stainless Steel	303
③ Socket	1	1206-	4C	5C	6C	8C	10C	12C	16C	Stainless Steel	303 or 304

All dimensions in inches.

Dimensional information is for reference only.

Variations from these dimensions, on actual parts, may occur as the result of engineering revisions.

# Hose Fittings

## PTFE

### SAE 37° flare swivel (JIC) 190600-C

for use with Hose 2807

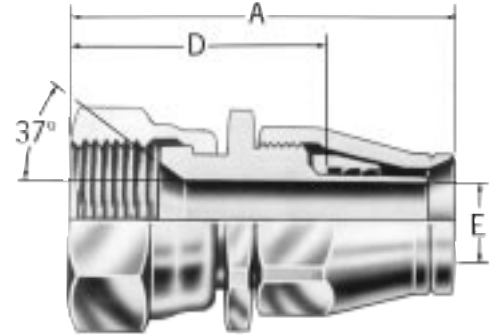

PART NUMBER	O.D. TUBE SIZE	THREAD	A	B	D	E	WT. EA. (LBS.)
190600-4C	¼	⅜-20	1.58	.76	1.13	.16	.07
190600-5C	⅝	½-20	1.68	.77	1.17	.23	.08
190600-6C	¾	⅝-18	1.74	.82	1.22	.26	.10
190600-8C	½	¾-16	1.98	.91	1.35	.38	.19
190600-10C	⅝	⅜-14	2.22	1.02	1.54	.47	.26
190600-12C	¾	1⅛-12	2.33	1.10	1.67	.59	.38
190600-16C	1	1⅝-12	2.52	1.31	1.91	.83	.56
190600-20C	1¼	1⅞-12	2.92	1.63	2.27	1.06	1.18

COMPONENTS DESCRIPTION	REQ'D. PER ASS'Y.	PART NUMBER BASE NO.	PART NUMBER SIZE								MATERIAL	MATERIAL SPECIFICATION
			4	5	6	8	10	12	16	20		
① Socket	1	1206-	4C	5C	6C	8C	10C	12C	16C	20C	Stainless Steel	AISI 303 or 304
② Sleeve	1	900568-	4C	5C	6C	8C	10C	12C	16C	20C	Stainless Steel	AISI 303
③ Nipple Assembly	1	473A-	4C	5C	6C	8C	10C	12C	16C	20C	Stainless Steel	see below
Nipple	1	1266-	4C	5C	6C	8C	10C	12C	16C	20C	Stainless Steel	AISI 303
Nut	1	210204-	4C	5C	6C	8C	10C	12C	16C	20C	Stainless Steel	AISI 303

All dimensions in inches.

Dimensional information is for reference only.

Variations from these dimensions, on actual parts, may occur as the result of engineering revisions.

# Hose Fittings

## PTFE

### Male O-Ring seal union (C.P.V.) FC5707-108

for use with Hose 2807

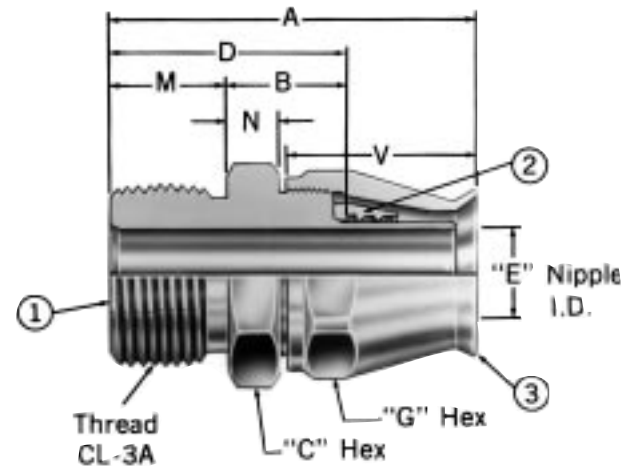

PART NUMBER	O.D. TUBE SIZE	THREAD	A	B	C	D	E	G	M	N	V
FC5707-0408-108	1/4	1 1/8-12	1.85	.60	1.25	1.22	.36	.88	.62	.25	.96

COMPONENTS	REQ'D. PER ASS'Y.	PART NUMBER		MATERIAL	MATERIAL SPECIFICATION
		BASE NO.	SIZE		
DESCRIPTION			0408		
① Nipple	1	FC2925-	0408-10	Stainless Steel	QQ-S-763, 304
② Sleeve	1	900568-	8C	Stainless Steel	303
③ Socket	1	1206-	8C	Stainless Steel	303 or 304

All dimensions in inches.

Dimensional information is for reference only.

Variations from these dimensions, on actual parts, may occur as the result of engineering revisions.

# Hose Fittings

## PTFE

### Reusable Fittings

for use with Hose 2807

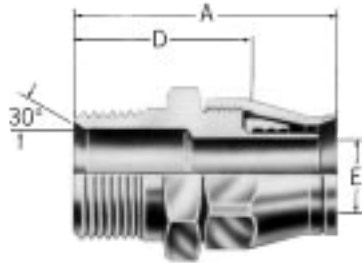

#### Male pipe

38-190627

DASH SIZE	THREAD	HOSE SIZE	A	D	EØ
<b>38-190627-</b>					
2-4	¼-27	-04	1.35	.89	.16
4-4	¼-18	-04	1.54	1.08	.16
4-5	¼-18	-05	1.58	1.07	.23
4-6	¼-18	-06	1.66	1.13	.28
6-6	¾-18	-06	1.66	1.13	.28
6-8	¾-18	-08	1.79	1.16	.38
8-10	½-14	-10	2.13	1.46	.47
12-12	¾-14	-12	2.26	1.61	.59
16-16	1-11½	-16	2.48	1.86	.83
20-20	1¼-11½	-20	2.83	2.17	1.06

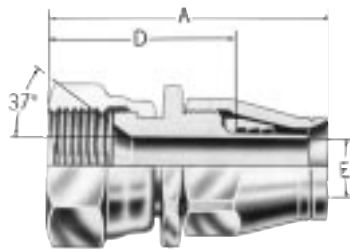

#### SAE 37° (JIC) swivel

63-190600

DASH SIZE	THREAD	HOSE SIZE	A	D	EØ
<b>63-190600-</b>					
3*	¾-24	-03	1.38	1.04	.09
4*	¾-20	-04	1.58	1.13	.16
5*	½-20	-05	1.68	1.17	.23
6*	¾-18	-06	1.74	1.22	.26
8*	¾-16	-08	1.98	1.35	.38
10*	¾-14	-10	2.22	1.54	.47
12*	1⅙-12	-12	2.33	1.67	.59
16*	1⅙-12	-16	2.52	1.91	.83
20*	1⅙-12	-20	2.92	2.27	1.06

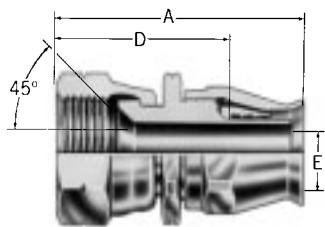

#### SAE 45° swivel

63-190990

DASH SIZE	THREAD	HOSE SIZE	A	D	EØ
<b>63-190990-</b>					
4	¾-20	-04	1.58	1.12	.16
5	½-20	-05	1.68	1.17	.23
6	¾-18	-06	1.77	1.25	.28
8	¾-16	-08	1.98	1.36	.38
10	¾-14	-10	2.22	1.54	.47
12	1⅙-14	-12	2.33	1.67	.59

\*Also supplied in stainless steel. Add suffix "C" to part number and delete prefix "63".

NOTE: Sleeve part number is 900568- (dash size).

All dimensions in inches.

Dimensional information is for reference only.

Variations from these dimensions, on actual parts, may occur as the result of engineering revisions.

# Hose Fittings

## PTFE

### Reusable Fittings

for use with Hose 2807

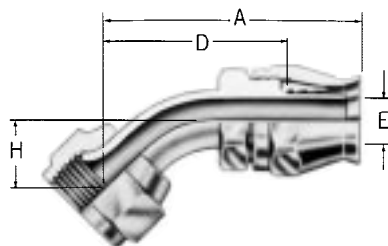

#### 45° elbow

190773- Universal

SAE 37° (JIC) swivel

FC9341- SAE 45° swivel

DASH SIZE	THREAD	HOSE SIZE	A	D	EØ	H
<b>190773-</b>						
3S	3/8-24	-03	1.50	1.17	.09	.46
4S	7/16-20	-04	1.51	1.05	.16	.33
5S	1/2-20	-05	1.62	1.11	.23	.36
6S†	9/16-18	-06	1.72	1.20	.28	.39
8S	3/4-16	-08	2.27	1.64	.38	.55
10S	7/8-14	-10	2.46	1.79	.47	.64
12S†	1 1/16-12	-12	2.86	2.21	.59	.78
16S	1 5/16-12	-16	3.30	2.68	.83	1.07
20S	1 5/8-12	-20	3.80	3.14	1.06	1.22
<b>FC9341-</b>						
0606S	5/8-18	-06	1.72	1.20	.28	.39
1212S	1 1/16-14	-12	2.86	2.21	.59	.78

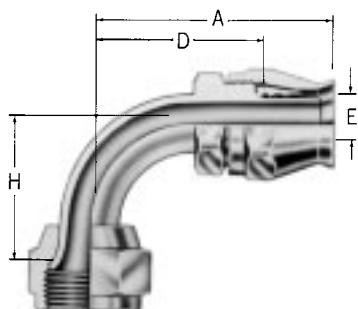

#### 90° elbow

190772- Universal

FC9171- SAE 45° swivel

DASH SIZE	THREAD	HOSE SIZE	A	D	EØ	H
<b>190772-</b>						
3S	3/8-24	-03	1.27	.93	.09	.87
4S	7/16-20	-04	1.41	.95	.16	.68
5S	1/2-20	-05	1.52	1.00	.23	.77
6S†	9/16-18	-06	1.62	1.10	.28	.85
8S	3/4-16	-08	2.03	1.41	.38	1.09
10S	7/8-14	-10	2.16	1.49	.47	1.23
10-12S	7/8-14	-12	2.23	1.57	.46	1.23
12S†	1 1/16-12	-12	2.82	2.17	.59	1.82
12-16S†	1 1/16-14	-16	2.87	2.22	.58	1.82
16S	1 5/16-12	-16	3.10	2.49	.82	2.39
<b>FC9171-</b>						
0606S	5/8-18	-06	1.62	1.10	.28	.85
1212S	1 1/16-14	-12	2.80	2.19	.59	1.82

\*Also supplied in stainless steel. Add suffix "C" to part number and delete prefix "63".

NOTE: Sleeve part number is 900568- (dash size).

†Universal type identification for both SAE 45° and 37° connections.

All dimensions in inches.

Dimensional information is for reference only.

Variations from these dimensions, on actual parts, may occur as the result of engineering revisions.

†For both SAE 45° and SAE 37° (JIC) connections

# Hose Fittings

## PTFE

### Dogleg 90° FJ9548-253

for use with Hose 2807

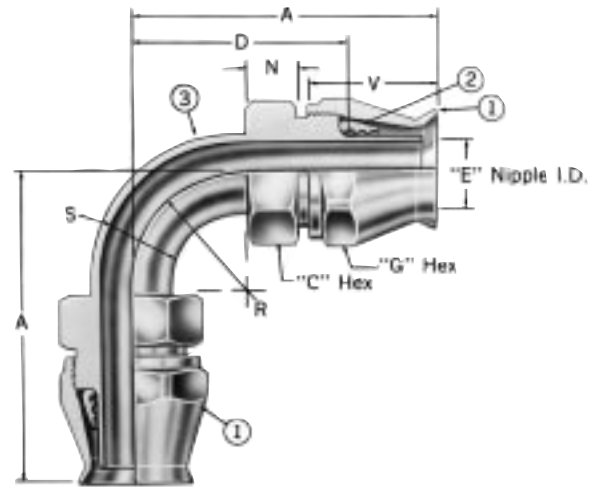

PART NUMBER	HOSE SIZE	A	C	D	E	G	N	R	S	V
FJ9548-0404-253	-04	1.81	.56	1.34	.16	.56	.58	.38	.25	.77
FJ9548-0606-253	-06	1.99	.69	1.46	.24	.81	.58	.50	.37	1.30

COMPONENTS DESCRIPTION	REQ'D. PER ASS'Y.	PART NUMBER BASE NO.	SIZE		MATERIAL	MATERIAL SPECIFICATION
			0404	0606		
① Socket	2	1206-	4C	6C	Stainless Steel	303 or 304
② Sleeve	2	900568-	4C	6C	Stainless Steel	303
③ Nipple Assembly	1	FJ8548-	0404-4	0606-4	see below	see below
Nipple	2	FC2926	0404-4	0606-4	Nickel Copper	QQ-N-281
Elbow	1	4-419037-	4	6	Nickel Copper	MIL-T-1368

All dimensions in inches.

Dimensional information is for reference only.

Variations from these dimensions, on actual parts, may occur as the result of engineering revisions.

# Hose Fittings

## PTFE

### Male pipe 190628-C

for use with Hose 2808

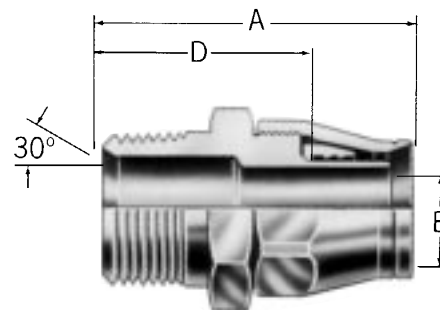

PART NUMBER	HOSE SIZE	THREAD	A	D	E	WT. EA. (LBS.)
190628-16-16C	-16	1-11½	2.63	1.87	.83	.66
190628-24-24C	-24	1 ½-11½	3.16	2.20	1.28	1.69

COMPONENTS	REQ'D. PER ASS'Y.	PART NUMBER BASE NO.	PART NUMBER SIZE		MATERIAL	MATERIAL SPECIFICATION
			16-16	24-24		
① Nipple	1	220572-	16-16C	24-24C	Stainless Steel	AISI 303
② Sleeve	1	900515-	16C	24C	Stainless Steel	AISI 303
③ Socket	1	1208-	16C	24C	Stainless Steel	AISI 303

All dimensions in inches.

Dimensional information is for reference only.

Variations from these dimensions, on actual parts, may occur as the result of engineering revisions.

# Hose Fittings

## PTFE

### SAE 37° flare swivel (JIC) 190535-C

for use with Hose 2808

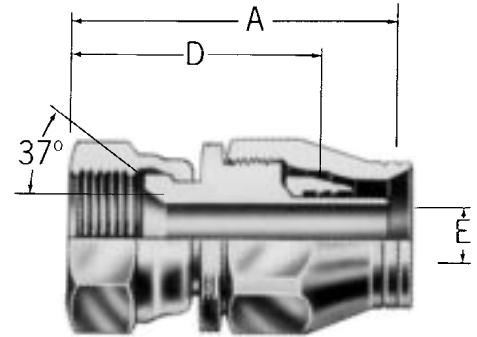

PART NUMBER	HOSE SIZE	THREAD	A	D	E	WT. EA. (LBS.)
190535-8C	-8	3/4-16	2.07	1.48	.35	.23
190535-10C	-10	7/8-14	2.22	1.64	.44	.32
190535-12C	-12	1 1/16-12	2.46	1.70	.56	.48
190535-16C	-16	1 5/16-12	2.66	1.90	.83	.67
190535-20C	-20	1 7/8-12	3.14	2.19	1.06	1.40
190535-24C	-24	1 7/8-12	3.38	2.42	1.28	1.86

COMPONENTS	REQ'D. PER ASS'Y.	PART NUMBER	PART NUMBER						MATERIAL	MATERIAL SPECIFICATION
			BASE NO.	8	10	12	16	20		
① Socket	1	1208-	8C	10C	12C	16C	20C	24C	Stainless Steel	303
② Sleeve	1	900515-	8C	10C	12C	16C	20C	24C	Stainless Steel	303
③ Nipple Assembly	1	185535-	8C	10C	12C	16C	20C	24C	Stainless Steel	see below
Nipple	1	220554-	8C	10C	12C	16C	20C	24C	Stainless Steel	303
Nut	1	210204-	8C	10C	12C	16C	20C	24C	Stainless Steel	303

All dimensions in inches.

Dimensional information is for reference only.

Variations from these dimensions, on actual parts, may occur as the result of engineering revisions.

# Hose Fittings

## PTFE

### Male O-Ring seal union (C.P.V.) FJ9401-253

for use with Hose 2808

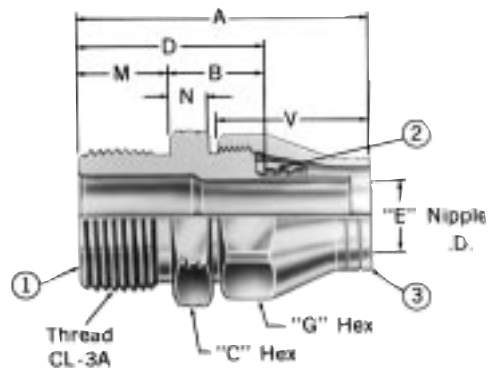

PART NUMBER	I.P.S. SIZE	THREAD	A	B	C	D	E	G	M	N	V
FJ9401-0408-253	¼	1½-12	2.05	.71	1.25	1.46	.35	.94	.62	.38	1.02
FJ9401-2024-253	1¼	2¼-12	3.04	1.32	2.88	2.07	1.28	2.25	.75	.62	1.65

COMPONENTS	REQ'D. PER ASS'Y.	PART NUMBER	SIZE		MATERIAL	MATERIAL SPECIFICATION
			BASE NO.	0408		
DESCRIPTION						
① Nipple	1	FC1266-	0408-4	2024-4	Nickel Copper	QQ-N-281
② Sleeve	1	900515-	8C	24C	Stainless Steel	303
③ Socket	1	1208-	8C	24C	Stainless Steel	316

All dimensions in inches.

Dimensional information is for reference only.

Variations from these dimensions, on actual parts, may occur as the result of engineering revisions.

# Hose Fittings

## PTFE

### Male pipe 38-190628

for use with Hose 2808

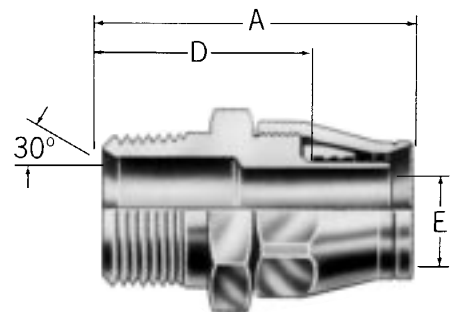

PART NUMBER	HOSE SIZE	THREAD	A	D	E	WT. EA. (LBS.)
38-190628-6-8	-8	3/8-18	1.91	1.32	.35	.21
38-190628-8-10	-10	1/2-14	2.12	1.55	.44	.30
38-190628-12-12	-12	3/4-14	2.40	1.63	.56	.46
38-190268-16-16	-16	1-11 1/2	2.63	1.86	.83	.66
38-190628-20-20	-20	1 1/4-11 1/2	3.05	2.09	1.06	1.18
38-190628-24-24	-24	1 1/2-11 1/2	3.16	2.20	1.29	1.69

COMPONENTS DESCRIPTION	REQ'D. PER ASS'Y.	PART NUMBER BASE NO.	PART NUMBER SIZE						MATERIAL
			6-8	8-10	12-12	16-16	20-20	24-24	
① Nipple	1	220572-	6-8B	8-10B	12-12B	16-16B	20-20B	24-24B	Brass
② Sleeve	1	900515-	8B	10B	12B	16B	20B	24B	Brass
③ Socket	1	1208-	8S	10S	12S	16S	20S	24S	Steel

All dimensions in inches.

Dimensional information is for reference only.

Variations from these dimensions, on actual parts, may occur as the result of engineering revisions.

# Hose Fittings

## PTFE

### SAE 37° flare swivel (JIC) 63-190535

for use with Hose 2808

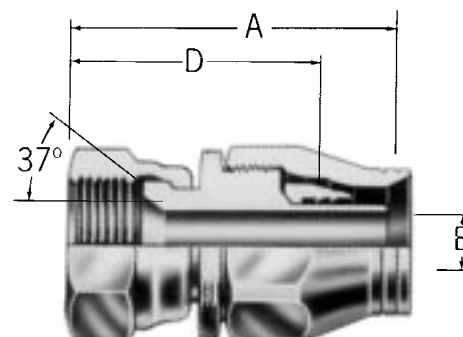

PART NUMBER	O.D. TUBE SIZE	THREAD	A	D	E	WT. EA. (LBS.)
63-190535-8	½	¾-16	2.07	1.48	.35	.23
63-190535-10	⅝	⅞-14	2.22	1.64	.44	.32
63-190535-12	¾	1 ⅛-12	2.46	1.70	.56	.48
63-190535-16	1	1 ⅝-12	2.66	1.90	.83	.67
63-190535-20	1 ¼	1 ¾-12	3.14	2.19	1.06	1.40
63-190535-24	1 ½	1 ⅞-12	3.38	2.42	1.29	1.86

COMPONENTS DESCRIPTION	REQ'D. PER ASS'Y.	PART NUMBER BASE NO.	SIZE						MATERIAL	MATERIAL SPECIFICATION
			8	10	12	16	20	24		
① Socket	1	1208-	8S	10S	12S	16S	20S	24S	Steel	C1213
② Sleeve	1	900515-	8B	10B	12B	16B	20B	24B	Brass	
③ Nipple Assembly	1	63-185535-	8	10	12	16	20	24	see below	see below
Nipple	1	220554-	8B	10B	12B	16B	20B	24B	Brass	
Nut	1	210204-	8S	10S	12S	16S	20S	24S	Steel	1137 or 11L37

All dimensions in inches.

Dimensional information is for reference only.

Variations from these dimensions, on actual parts, may occur as the result of engineering revisions.

# Hose Fittings

## PTFE

### SAE 37° (JIC) flare swivel 90° FJ9525-253

for use with Hose 2808

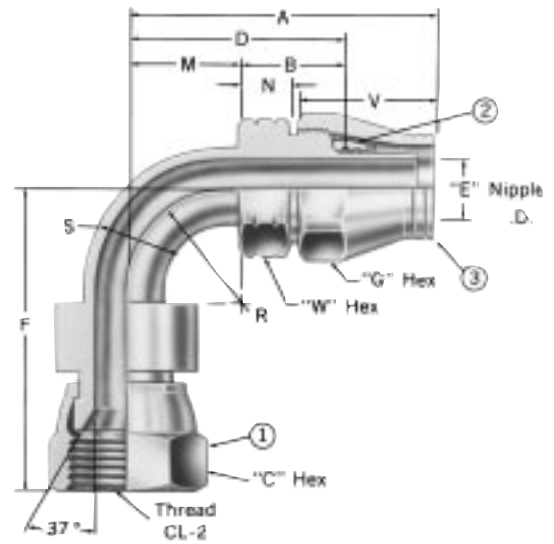

PART NUMBER	HOSE SIZE	THREAD	A	B	D	E	F	G	M	N	R	S	C	V	W
FJ9525-0808-253	-08	3/4-16	2.52	1.10	1.93	.38	2.16	.94	.83	.67	.75	.50	.88	1.02	.78
FJ9525-1212-253	-12	1 1/8-12	3.37	1.29	2.60	.56	3.01	1.25	1.31	.80	1.25	.75	1.25	1.26	1.13
FJ9525-1616-253	-16	1 1/8-12	3.63	1.29	2.86	.83	3.49	1.50	1.57	.76	1.50	1.00	1.50	1.30	1.43
FJ9525-2020-253	-20	1 1/8-12	4.24	1.46	3.28	1.03	3.75	1.88	1.82	.86	1.75	1.25	2.00	1.56	1.75

COMPONENTS DESCRIPTION	REQ'D. PER ASS'Y.	PART NUMBER BASE NO.	SIZE				MATERIAL	MATERIAL SPECIFICATION
			0808	1212	1616	2020		
① Nipple Assembly	1	FJ8525-	0808-4	1212-4	1616-4	2020-4	see below	see below
Nipple	1	FC2760-	0808-4	1212-4	1616-4	2020-4	Monel	QQ-N-281
Elbow	1	4-419037-	8	12			Monel	MIL-T-1368
Elbow	1	15-419037-			16	20	Copper Nickel	MIL-T-16420
Shoulder	1	FC2762-	0808-4	1212-4	1616-4	2020-4	Monel	QQ-N-281
Nut	1	4-210204-	8	12	16	20	Monel	QQ-N-281
② Sleeve	1	900515-	8C	12C	16C	20C	Stainless Steel	AISI 303
③ Socket	1	1208-	8C	12C	16C	20C	Stainless Steel	AISI 303

All dimensions in inches.

Dimensional information is for reference only.

Variations from these dimensions, on actual parts, may occur as the result of engineering revisions.

# Hose Fittings

## PTFE

### Dogleg 90° FC5307-253

for use with Hose 2808

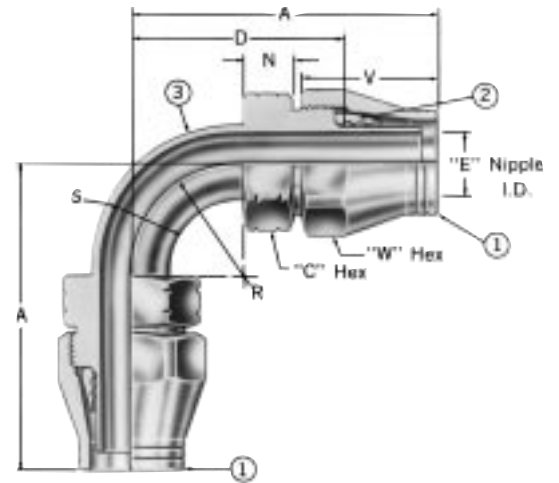

PART NUMBER	A	C	D	E	N	R	S	V	W
FC5307-0808-253	2.52	.88	1.93	.35	.67	.75	.50	1.03	.94
FC5307-1212-253	3.36	1.13	2.54	.56	.79	1.25	.75	1.26	1.25
FC5307-1616-253	3.63	1.44	2.86	.75	.77	1.50	1.00	1.30	1.50
FC5307-2020-253	4.24	1.75	3.28	1.03	.86	1.75	1.25	1.56	1.88
FC5307-2424-253	4.58	2.06	3.61	1.28	.86	2.00	1.50	1.65	2.25

COMPONENTS DESCRIPTION	REQ'D. PER ASS'Y.	PART NUMBER BASE NO.	SIZE					MATERIAL	MATERIAL SPECIFICATION
			0808	1212	1616	2020	2424		
① Socket	2	1208-	8C	12C	16C	20C	24C	Stainless Steel	300 Series
② Sleeve	2	900515-	8C	12C	16C	20C	24C	Stainless303 Steel	
③ Nipple Assembly	1	FC4307	0808-4	1212-4	1616-4	2020-4	2424-4	see below	see below
Nipple	1	FC2760-	0808-4	1212-4	1616-4	2020-4	2424-4	Monel	QQ-N-281
Elbow	1	4-419037-	8	12				Copper Nickel	MIL-T-1368
Elbow	1	15-419037-			16	20	24	Nickel Copper	MIL-T-16420

All dimensions in inches.

Dimensional information is for reference only.

Variations from these dimensions, on actual parts, may occur as the result of engineering revisions.

# Hose Fittings

## PTFE

### Steel 150 lb. flange Mates with A.N.S.I. B16.5 FC7862-228

for use with Hose 2808

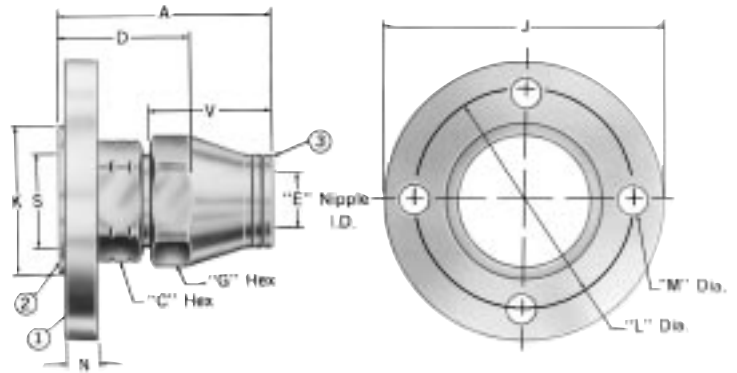

PART NUMBER	A	C	D	E	G	J	K	L	M	N	S	V
FC7862-0808-228	2.17	1.12	1.58	.35	.94	3.50	1.50	2.38	.62	.38	.71	1.02
FC7862-1212-228	2.40	1.38	1.63	.56	1.25	3.88	1.84	2.75	.62	.44	.92	1.26
FC7862-1616-228	2.38	1.62	1.61	.83	1.50	4.25	2.12	3.12	.62	.44	1.18	1.30
FC7862-2020-228	2.82	2.12	1.86	1.06	1.88	4.62	2.74	3.50	.62	.44	1.53	1.56
FC7862-2024-228	2.91	2.12	1.94	1.28	2.25	4.62	2.74	3.50	.62	.44	1.77	1.65
FC7862-2424-228	2.91	2.12	1.94	1.28	2.25	5.00	2.74	3.88	.62	.44	1.77	1.65
FC7862-3224-228	2.91	2.12	1.94	1.28	2.25	6.00	2.74	4.75	.75	.44	1.77	1.65

COMPONENTS DESCRIPTION	REQ'D. PER ASS'Y.	PART NUMBER BASE NO.	SIZE						MATERIAL	MATERIAL SPECIFICATION
			0808	1212	1616	2020	2424	3224		
① Flange	1	74021-	½-16S	¾-20S	1-24S	1¼-32S	1½-32S	2-32S	Steel	AISI 1018, 1020 or M1020 HRS
② Nipple	1	FC2552-	0808C	1212C	1616C	2020C	2424C	2424C	Stainless Steel	AISI 303
③ Socket	1	1208-	8C	12C	16C	20C	24C	24C	Stainless Steel	300 Series
Sleeve	1	900515-	8C	12C	16C	20C	24C	24C	Stainless Steel	AISI 303

All dimensions in inches.

Dimensional information is for reference only.

Variations from these dimensions, on actual parts, may occur as the result of engineering revisions.

# Hose Fittings

## PTFE

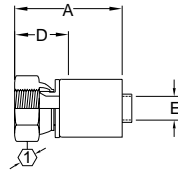

SAE 37° (JIC)  
FJ9587 swivel

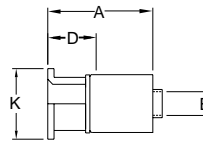

Flange Retainer  
FJ9656

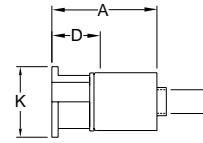

Flange Retainer  
with Teflon  
coated nipple  
FJ9656

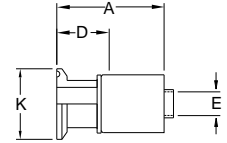

Ladish  
Tri-Clamp\*  
FJ7041

For use with Hose  
FC363, FC364

COMPLETE FITTING PART NUMBER STAINLESS STEEL	COMPONENT PART NUMBERS		HOSE SIZE	A	D	E Ø	K Ø	①	②
	NIPPLE ASSY. STAINLESS STEEL	SOCKET STAINLESS STEEL THREAD							
<b>Male pipe stainless steel</b>									
FJ9588-0808-341	FC1349-0808-259	FC1347-08-329	½-14	-08	2.54	1.30	.41		.88
FJ9588-1212-341	FC1349-1212-259	FC1347-12-329	¾-14	-12	2.61	1.37	.61		1.12
FJ9588-1616-341	FC1349-1616-259	FC1347-16-329	1-11½	-16	2.80	1.55	.81		1.38
FJ9588-2020-341	FC1349-2020-259	FC1347-20-329	1¼-11½	-20	2.95	1.70	1.05		1.75
FJ9588-2424-341	FC1349-2424-259	FC1347-24-329	1½-11½	-24	3.20	1.74	1.28		2.00
FJ9588-3232-341	FC1349-3232-259	FC1347-32-329	2-11½	-32	3.46	1.96	1.75		2.50
<b>SAE 37° (JIC) swivel stainless steel</b>									
FJ9587-0808-331	FJ8587-0808-331	FC1347-08-329	¾-16	-08	2.52	1.10	.38		.88
FJ9587-1212-331	FJ8587-1212-331	FC1347-12-329	1⅙-12	-12	2.55	1.23	.61		1.25
FJ9587-1616-331	FJ8587-1616-331	FC1347-16-329	1⅙-12	-16	2.69	1.37	.81		1.50
FJ9587-2020-331	FJ8587-2020-331	FC1347-20-329	1⅞-12	-20	2.84	1.52	1.05		2.00
FJ9587-2424-331	FJ8587-2424-331	FC1347-24-329	1⅞-12	-24	3.21	1.67	1.28		2.25
FJ9587-3232-331	FJ8587-3232-331	FC1347-32-329	2½-12	-32	3.50	1.92	1.75		2.88
<b>Flange retainer stainless steel</b>									
FJ9656-0808-331	FC1373-0808-259	FC1347-08-329		-08	2.56	1.24	.41	1.38	
FJ9656-1212-331	FC1373-1212-259	FC1347-12-329		-12	2.56	1.24	.61	1.69	
FJ9656-1616-331	FC1373-1616-259	FC1347-16-329		-16	2.62	1.30	.81	2.00	
FJ9656-2020-331	FC1373-2020-259	FC1347-20-329		-20	2.62	1.30	1.05	2.50	
FJ9656-2424-331	FC1373-2424-259	FC1347-24-329		-24	3.01	1.48	1.28	2.87	
FJ9656-3232-331	FC1373-3232-259	FC1347-32-329		-32	3.05	1.48	1.75	3.62	
<b>Flange retainer with Teflon coated nipple</b>									
FJ9656-0808-338	FC1373-0808-337	FC1347-08-329		-08	2.56	1.24	.41	1.38	
FJ9656-1212-338	FC1373-1212-337	FC1347-12-329		-12	2.56	1.24	.61	1.69	
FJ9656-1616-338	FC1373-1616-337	FC1347-16-329		-16	2.62	1.30	.81	2.00	
FJ9656-2020-338	FC1373-2020-337	FC1347-20-329		-20	2.62	1.30	1.05	2.50	
FJ9656-2424-338	FC1373-2424-337	FC1347-24-329		-24	3.01	1.48	1.28	2.87	
FJ9656-3232-338	FC1373-3232-337	FC1347-32-329		-32	3.05	1.48	1.75	3.62	
<b>Ladish Tri-Clamp*</b>									
FJ7041-2416-331	FC1531-2416-259	FC1347-16-329		-16	1.98	.76	.81	1.98	
FJ7041-2424-331	FC1531-2424-259	FC1347-24-329		-24	2.24	.76	1.27	1.98	
FJ7041-3232-331	FC1531-3232-259	FC1347-32-329		-32	2.24	.76	1.75	2.51	

\*Tri-Clamp is a registered trademark of the Ladish Co., Tri-clover Division.

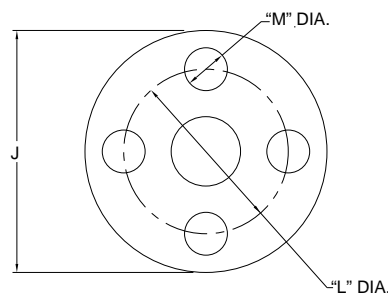

Flange FC1389

PART NUMBER STAINLESS STEEL	HOSE SIZE	NUMBER BOLT HOLES	J	L	M
FC1389-1212C	-12	4	3.88	2.75	.62
FC1389-1616C	-16	4	4.25	3.12	.62
FC1389-2020C	-20	4	4.62	3.50	.62
FC1389-2424C	-24	4	5.00	3.88	.62
FC1389-3232C	-32	4	6.00	4.75	.75

# Adapters

## Adapter Part Number Index

<b>SECTION</b>	<b>PAGES</b>
<b>Master Index</b>	<b>3-6</b>
<b>"FH" Competitor Part Number Conversion Chart</b>	<b>7</b>
<b>Hose</b>	<b>8-23</b>
<b>Fittings</b>	<b>24-141</b>
<b>Adapters</b>	<b>142-144</b>
<b>Accessories Assembly Instructions And Assembly equipment</b>	<b>145-173</b>
<b>Technical Data</b>	<b>174-205</b>

<b>ADAPTERS</b>	<b>PAGE</b>
<b>SAE 37° MALE FLARE TO MALE/FEMALE SIL-BRAZE</b>	
4-202140	143
4-202142	143
4-202240	144
4-202242	144
<b>SAE 37° MALE FLARE TO SOCKET WELD PIPE</b>	
446-202232	144



# Adapters

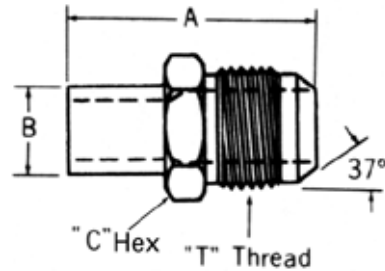

## SAE 37° MALE FLARE/MALE SIL-BRAZE, TUBING FOR ULTRASONIC TESTING

4-202140

DASH SIZE	TUBE O.D.	THREAD T	A	B	C
<b>4-202140-</b>					
4-4	¼	⅞-20	1.36	.25	.50
6-6	⅜	⅞-18	1.43	.38	.62
8-8	½	¾-16	1.63	.50	.81
12-12	¾	1⅛-12	2.06	.75	1.12
16-16	1	1⅝-12	2.35	1.00	1.38
20-20	1¼	1⅞-12	2.59	1.25	1.69
24-24	1½	1⅞-12	3.02	1.50	2.00
32-32	2	2½-12	3.58	2.00	2.62

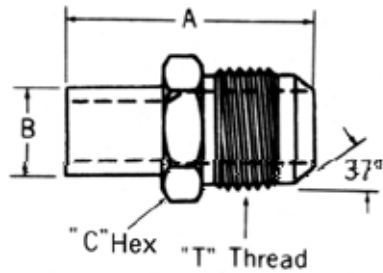

## SAE 37° MALE FLARE/MALE SIL-BRAZE, PIPE FOR ULTRASONIC TESTING

4-202142

DASH SIZE	I.P.S. SIZE	THREAD T	A	B	C
<b>4-202142-</b>					
¼-4	¼	⅞-20	1.36	.40	.50
¼-6	¼	⅞-18	1.43	.54	.62
¼-8	¼	¾-16	1.53	.54	.81
⅜-6	⅜	⅞-18	1.52	.67	.69
⅜-8	⅜	¾-16	1.63	.67	.81
⅜-10	⅜	⅞-14	1.79	.67	.94
½-8	½	¾-16	1.78	.84	.94
½-10	½	⅞-14	1.88	.84	.94
½-12	½	1⅛-12	2.06	.84	1.12
½-16	½	1⅝-12	2.10	.84	1.38
¾-16	¾	⅞-12	2.35	1.05	1.38
¾-20	¾	1⅞-12	2.46	1.05	1.69
1-20	1	1⅞-12	2.59	1.31	1.69
1-24	1	1⅞-12	2.77	1.31	1.94
1¼-24	1¼	1⅞-12	3.02	1.66	1.94
1½-24	1½	1⅞-12	3.14	1.90	2.00
1½-32	1½	2½-12	3.58	1.90	2.56
2-32	2	2½-12	3.77	2.38	2.56

All dimensions in inches.

# Adapters

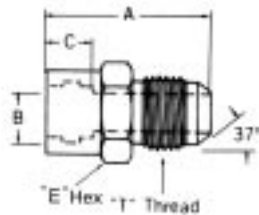

## SAE 37° MALE FLARE/FEMALE SIL-BRAZE, TUBE FOR ULTRASONIC TESTING\*

4-202240

DASH SIZE	TUBE O.D.	THREAD "T"	A	B	C	ITEM NO.	E
<b>4-202240-</b>							
4-4	¼	⅞-20	1.05	.25	.25	2	.69
6-6	⅜	⅞-18	1.24	.38	.31	2	.88
8-8	½	¾-16	1.41	.50	.47	2	1.00
12-12	¾	1⅛-12	2.04	.75	.56	2	1.44
16-16	1	1⅝-12	2.21	1.00	.69	1	1.69
20-20	1¼	1⅞-12	2.44	1.25	.81	1	2.00
24-24	1½	1⅞-12	2.88	1.50	.94	2	2.44
2-32	2	2½-12	3.33	2.00	1.06	2	2.88

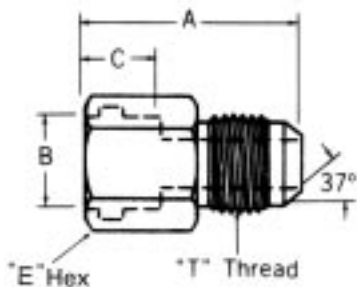

## SAE 37° MALE FLARE/FEMALE SIL-BRAZE, PIPE FOR ULTRASONIC TESTING\*\*

4-202242

DASH SIZE	I.P.S. SIZE	THREAD "T"	A	B	C	ITEM NO.	E
<b>4-202242-</b>							
¼-4	⅞	⅞-20	1.05	.41	.38	2	.69
¼-6	¼	⅞-18	1.24	.54	.38	2	.88
¼-8	¼	¾-16	1.34	.54	.38	2	.88
⅜-6	⅜	⅞-18	1.31	.68	.47	1	1.00
⅜-8	⅜	¾-16	1.41	.68	.47	1	1.00
⅜-10	⅜	⅞-14	1.51	.68	.47	1	1.00
½-10	½	⅞-14	1.93	.84	.56	2	1.44
½-12	½	1⅛-12	2.04	.84	.56	2	1.44
½-16	½	1⅝-12	2.08	.84	.56	2	1.44
¾-12	¾	1⅛-12	2.16	1.05	.69	2	1.69
¾-16	¾	1⅝-12	2.21	1.05	.69	2	1.69
¾-20	¾	1⅞-12	2.26	1.05	.69	2	1.69
1-16	1	1⅝-12	2.40	1.32	.81	2	2.00
1-20	1	1⅞-12	2.44	1.32	.81	2	2.00
1-24	1	1⅞-12	2.57	1.32	.81	2	2.00
2-32	2	2½-12	3.64	2.38	1.25	2	3.25

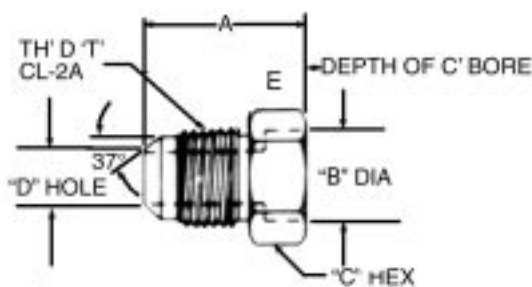

## SAE 37° MALE FLARE TO SOCKET WELD PIPE, SCHEDULE 80

446-202232

DASH SIZE	I.P.S. SIZE	TH D "T"	A	B	C	D	E
<b>446-202232-</b>							
¼-4	¼	⅞-20	1.09	1.12	.17	.56	.40
¼-6	¼	⅞-18	1.10	1.12	.30	.56	.40
¼-8	¼	¾-16	1.20	1.12	.39	.56	.40
⅜-6	⅜	⅞-18	1.24	1.25	.30	.70	.40
⅜-10	⅜	⅞-14	1.31	1.25	.48	.70	.40
½-6	½	⅞-18	1.28	1.38	.30	.86	.52
½-10	½	⅞-14	1.48	1.38	.48	.86	.52
½-12	½	1⅛-12	1.54	1.38	.61	.86	.52
½-16	½	1⅝-12	1.63	1.38	.84	.86	.52
¾-12	¾	1⅛-12	1.67	1.62	.61	1.07	.58
¾-16	¾	1⅝-12	1.72	1.62	.84	1.07	.58
1-16	1	1⅝-12	1.80	1.75	.84	1.34	.65
1-20	1	1⅞-12	1.81	1.75	1.08	1.34	.65
1-24	1	1⅞-12	2.14	2.00	1.26	1.34	.65
1½-24	1½	1⅞-12	1.95	2.38	1.31	1.92	.71
1½-32	1½	2½-12	2.35	2.63	1.78	1.92	.85

\* Recommended Aeroquip Braze Ring  
FF9081- O.D. Tube size - Item Number.

\*\*Recommended Aeroquip Braze Ring  
FF9082-IPS size-item number

† Not furnished. Must be ordered separately.

All dimensions in inches.

# Accessories Number Index

SECTION	PAGES
Master Index	3-6
ÒFHÓ Competitor Part Number Conversion Chart	7
Hose	8-23
Fittings	24-141
Adapters	142-144
Accessories Assembly Instructions And Assembly equipment	145-173
Technical Data	174-205

HOSE AND ACCESSORIES	PAGE
<b>LOW PRESSURE</b>	
2565	11
2556	11
<b>MEDIUM PRESSURE</b>	
303/302A	12
FC163	15
FC173	12
2665	13
AE372	13
FC234	14
AE369	14
2580 -4 thru -32	15
<b>HIGH PRESSURE</b>	
AE373	16
FC162	16
AE374	17
AE370	17
AE371	18
2766	18
<b>LARGE BORE</b>	
FC132	19
2580 -80 thru -192	19
150901	20
2758	20
<b>PTFE (Teflon*)</b>	
FC363	21
FC364	21
2807	22
2808	22
<b>Specials</b>	
678 (Hose Assemblies)	23

\*Teflon is a DuPont trademark



# Accessories

## Protective Coils, Sleeves & Clamps

222005, 222022  
Stainless steel internal  
support coils



Recommended for vacuum service with most hose.

FOR USE WITH HOSE:  
SEE PAGES 149-152.

PART NUMBER	COIL O.D. (INCHES)
222005-23C	.34
222005-10C	.42
222005-21C	.51
222005-11C	.60
222022-12C	.70
222005-13C	.73
222005-14C	.94
222022-16C	.97
222005-15C	1.19
222022-20C	1.25
222005-17C	1.44
222022-24C	1.50
222005-18C	1.88
222022-32C	1.97
222005-19C	2.44
222022-40C	2.67
222022-48C	3.27

900705  
Steel protective coil sleeve



Recommended for use where hose lines are subjected to excessive abrasion, kinking or accidental damage. Construction: spring steel, rust resistant.

This coil should fit snugly to the hose O.D. expanding the coil I.D. (unwind the coil) may be necessary for proper installation.

FOR USE WITH HOSE:  
SEE PAGES 149-152.

SLEEVE DASH NO.	SLEEVE I.D. (INCHES)
Ø17S	.44
Ø1S	.50
Ø13S	.57
Ø2S	.63
Ø3S	.75
Ø4S	.88
Ø5S	1.03
Ø14S	1.13
Ø6S	1.22
Ø7S	1.47
Ø9S	1.69
Ø8S	1.91
Ø15S	2.00
Ø10S	2.13
Ø16S	2.44
Ø11S	2.56
Ø12S	2.75

900564  
Steel protective coil spring



Protects hose cover and reinforcement from abrasion and accidental damage. Construction; steel wire, rust resistant.

This coil should fit snugly to the hose O.D. expanding the coil I.D. (unwind the coil) may be necessary for proper installation.

FOR USE WITH HOSE:  
SEE PAGES 149-152.

SPRING DASH NO.	SPRING I.D. (INCHES)
Ø1S	.61
Ø12S	.67
Ø2S	.75
Ø15S	.81
Ø14S	.85
Ø3S	.91
Ø4S	1.04
Ø5S	1.18
Ø6S	1.34
Ø7S	1.66
Ø9S	1.87
Ø8S	2.13
Ø10S	2.38
Ø13S	2.75
Ø11S	2.88

900952  
Plastic protective coil sleeve

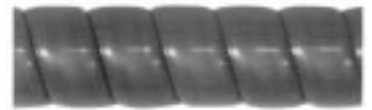

Recommended to protect hose from abrasion, this light weight plastic sleeve is unaffected by air, water, oil, gasoline, hydraulic and most other fluids. This coil can also be used for group bundling of hose lines. Temperature range of 0°F to +180°F.

FOR USE WITH HOSE:  
SEE PAGES 149-152.

SLEEVE DASH NO.	SLEEVE I.D. (INCHES)
Ø4	.25
Ø6	.38
Ø8	.50
Ø10	.63
Ø12	.75
Ø16	1.00
Ø22	1.38
Ø30	1.88

# Accessories

## Protective Coils, Sleeves & Clamps

624 Firesleeve



Firesleeve will protect hose from direct flame. Firesleeve is constructed of a uniform single layer of braided fiber-glass tubing impregnated with flame resistant silicone rubber. Temperature range of -65°F to +500°F.

FOR USE WITH HOSE:  
SEE PAGES 149-152.

ASSEMBLY INSTRUCTIONS SEE  
PAGE 161

PART NUMBER	I.D. (IN.)	CLAMP NUMBER (2 REQUIRED)
624-5	.31	FF9217-0622S
624-7	.44	FF9217-0622S
624-8	.50	FF9217-0622S
624-9	.56	FF9217-0622S
624-10	.62	FF9217-0622S
624-11	.69	FF9217-0622S
624-12	.75	FF9217-0622S
624-13	.81	FF9217-0622S
624-14	.88	FF9217-0622S
624-16	1.00	FF9217-0622S
624-18	1.12	FF9217-0622S
624-20	1.25	FF9217-0648S
624-22	1.38	FF9217-0648S
624-24	1.50	FF9217-0648S
624-26	1.62	FF9217-0648S
624-28	1.75	FF9217-0648S
624-30	1.88	FF9217-0648S
624-32	2.00	FF9217-0648S
624-38	2.38	FF9217-0648S
624-42	2.62	FF9217-0648S
624-46	2.88	FF9217-0664C
624-50	3.12	FF9217-0664C
624-54	3.38	FF9217-0664C
624-60	3.75	FF9217-0664C

FF9217 Firesleeve clamp



Recommended for attaching 624 Firesleeve to hose lines.

Clamp numbers:  
FF9217-0622S, FF9217-0648S;  
3/4 inch wide, FF9217-0664C;  
1 inch wide.

FOR USE WITH HOSE:  
SEE PAGES 149-152.

FC425 Nylon abrasion sleeve  
Meets MSHA requirements

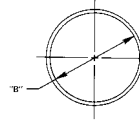

Nylon sleeve protects hose from abrasion and allows bundling of hose lines.

FOR USE WITH HOSE:  
SEE PAGES 149-152.

PART NUMBER	NOMINAL SLEEVE I.D.* OBO (INCHES)
FC425-12	.71
FC425-15	.92
FC425-16	1.00
FC425-18	1.13
FC425-20	1.25
FC425-24	1.59
FC425-28	1.75
FC425-32	2.07
FC425-38	2.38
FC425-40	2.54
FC425-46	2.86
FC425-54	3.34
FC425-59	3.66

\* The maximum O.D. of hose fittings must be allowed for if fittings are to be covered.



### Hose Cleaning System

The Jetcleaner<sup>®</sup> hose cleaning system offers a revolutionary solution for the internal cleaning of bulk hose and finished hose assemblies. Using a low pressure air gun, the Jetcleaner system routes a foam projectile through the hose to thoroughly remove debris remaining from cutting, skiving and assembly operations. Available in kit form or as individual components, the Jetcleaner<sup>®</sup> hose cleaning system is the system of choice for hose assembly professionals.

### Hose Kit (P/N FT1355-0 1)

Includes:

Jetcleaner<sup>®</sup> pistol, Hose nozzles, 1/4" through 2" ID, Adapter ring, Bench stand, Aluminum case, Quick disconnect coupling

Note: FT1355-3-size Hose projectiles not included in kit.

Also available individually:

- FT1355-1-01 Jetcleaner<sup>®</sup> pistol
- FT1355-2-size Hose nozzles
- FT1355-3-size Hose projectiles
- FT1355-4-size Coupling nozzles
- FT1355-5-size Coupling projectiles
- FT1355-10-01 Adapter ring
- FT1355-11-02 Carrying case
- FT1355-12-0 Bench stand



# Accessories & Equipment

## Coil, Sleeve & Clamp Chart

HOSE PART NUMBER	STEEL PROT. COIL SPRING*	PLASTIC COIL SLEEVE	STEEL PROT. COIL SLEEVE*	SUPPORT CLAMP	INTERNAL SUPPORT COIL	INTERNAL SLEEVE	NYLON SLEEVE*	FIRESLEEVE*	FIRESLEEVE CLAMP	SUPPORT CLAMP	HEAVY DUTY SUPPORT CLAMP
	900564 (DASH SIZE)	900952 (DASH SIZE)	900705 (DASH SIZE)	900729 (DASH SIZE)		FF9700- (DASH SIZE)	FC425 (DASH SIZE)	624 (DASH SIZE)	FF9217 (DASH SIZE)	FF90311 (DASH SIZE)	
150901-40				-16		222022-40C					
150901-48						222022-48C					
150901-64											-64-262
2556-4	-1S	-6	-1S	-1				-12	-9	-0622S	-127
2556-6	-12S	-8	-13S	-21				-16	-11	-0622S	-160
2556-8	-14S	-10	-3S	-4				-16	-13	-0622S	-190
2556-10	-4S	-12	-4S	-5				-16	-16	-0622S	-222
2556-12	-5S	-16	-5S	-23				-20	-18	-0630S	-266
2565-4	-1S	-6	-1S	-1				-12	-9	-0622S	-127
2565-6	-12S	-8	-13S	-21				-16	-11	-0622S	-160
2565-8	-14S	-10	-3S	-4				-16	-13	-0622S	-205
2565-10	-4S	-12	-4S	-6				-16	-16	-0622S	-239
2565-12	-5S	-16	-5S	-8				-20	-18	-0630S	-280
2580-4	-1S	-6	-1S	-1				-12	-11	-0622S	-127
2580-5	-12S	-8	-13S	-2				-12	-12	-0622S	-150
2580-6	-2S	-10	-2S	-21				-16	-14	-0622S	-174
2580-8	-14S	-12	-3S	-4		222005-10C		-16	-16	-0622S	-190
2580-10	-4S	-12	-4S	-6		222005-21C		-20	-18	-0630S	-239
2580-12	-5S	-16	-5S	-8		222005-13C		-20	-20	-0630S	-280
2580-16	-6S	-16	-6S	-27		222005-14C		-24	-24	-0648S	-320
2580-20	-7S	-22	-7S	-10		222005-15C		-28	-28	-0648S	-381
2580-24	-9S	-22	-9S	-12		222005-17C		-32	-32	-0648S	-445
2580-32	-10S	-30	-10S	-14		222005-18C		-40	-42	-0648S	-572
2580-80											-80-262
2580-96											-96-262
2580-128											-128-262
2580-160											-160-262
2580-192											222022-192C
2665-4	-12S	-8	-13S	-21				-16	-12	-0622S	
2665-6	-14S	-10	-3S	-4				-16	-18	-0630S	
2665-8	-4S	-12	-4S	-5				-20	-20	-0630S	
2665-10	-5S	-12	-5S	-23				-20	-20	0630S	
2665-12	-6S	-16	-14S	-27		222005-14C		-24	-22	0648S	
2665-16	-7S	-22	-7S	-10		222005-15C		-28	-28	-0648S	
2758-80											-80-262
2758-96											-96-262
2766-4	-2S	-8	-2S	-3				-16	-14	-0622C	-174
2766-6	-3S	-12	-3S	-5				-16	-16	-0630C	-222
2766-8	-4S	-12	-4S	-6				-18	-20	-0630C	-239
2766-12	-6S	-16	-6S	-24				-26	-24	-0648C	-320
2766-16	-7S	-22	-7S	-11				-30	-28	-0648C	-400
2766-20	-8S	-30	-8S	-13				-38	-38	-0648C	-508
2766-24	-10S	-30	-10S	-14				-42	-42	-0648C	-572
2766-32	-5S	-16	-5S	-8				-20	-20	-0630S	-700

\*Sizes indicated are based on Hose-OD only. If sleeve is to be placed over fitting, a larger sleeve size may be required, depending on type of fitting used.

# Accessories & Equipment

## Coil, Sleeve & Clamp Chart

HOSE PART NUMBER	STEEL PROT. COIL SPRING*	PLASTIC COIL SLEEVE	STEEL PROT. COIL SLEEVE*	SUPPORT CLAMP	INTERNAL SUPPORT	INTERNAL SLEEVE	NYLON SLEEVE*	FIRESLEEVE*	FIRESLEEVE CLAMP	SUPPORT CLAMP	HEAVY DUTY
	900564 (DASH SIZE)	900952 (DASH SIZE)	900705 (DASH SIZE)	900729 (DASH SIZE)	COIL	FF9700- (DASH SIZE)	FC425 (DASH SIZE)	624 (DASH SIZE)	FF9217 (DASH SIZE)	FF90311 (DASH SIZE)	
2807-3		-4		-18				-7		-0622S	
2807-4		-4		-18				-8		-0622S	
2807-5		-4		-19				-9		-0622S	
2807-6		-6	-17S	-01	222005-23C			-10		-0622S	
2807-8	-1S	-8	-1S	-1	222005-10C			-12	-12	-0622S	-137
2807-10	-2S	-8	-3S	-21	222005-21C			-16	-14	-0630S	-160
2807-12	-2S	-10	-3S	-4	222005-13C			-16	-16	-0630S	-190
2807-16	-3S	-12	-5S	-23	222005-14C			-20	-20	-0630S	-266
2807-20	-5S	-16	-6S	-24	222005-15C			-24	-24	-0648S	-320
2808-8	-12S	-6	-1S	-2	222005-10C			-12	-16	-0622S	-150
2808-10	-2S	-8	-2S	-3	222005-21C			-16	-18	-0630S	-174
2808-12	-14S	-10	-3S	-5	222005-13C			-16	-20	-0630S	-205
2808-16	-5S	-16	-5S	-8	222005-14C			-20	-26	-0648S	-280
2808-20	-7S	-16	-6S	-25	222005-15C			-24	-32	-0648S	-334
2808-24	-7S	-22	-7S	-11	222005-17C			-28	-38	-0648S	-422
302A-16	-6S	-16	-6S	-27	222005-14C			-24	-24	-0648S	-320
302A-20	-7S	-22	-7S	-10	222005-15C			-28	-30	-0648S	-381
302A-24	-9S	-22	-9S	-12	222005-17C			-32	-32	-0648S	-445
302A-32	-10S	-30	-10S	-14	222005-18C			-38	-38	-0648S	-572
303-4	-1S	-6	-1S	-1				-12	-11	-0622S	-127
303-5	-12S	-8	-13S	-2				-12	-12	-0622S	-150
303-6	-2S	-10	-2S	-21				-16	-14	-0622S	-174
303-8	-14S	-12	-3S	-4	222005-10C			-16	-16	-0622S	-190
303-10	-4S	-12	-4S	-6	222005-21C			-20	-18	-0630S	-239
303-12	-5S	-16	-5S	-8	222005-13C			-20	-20	-0630S	-280
AE369-4	-1S	-6	-1S	-1				-12	-11	-0622S	-137
AE369-5	-12S	-8	-13S	-2				-12	-12	-0622S	
AE369-6	-2S	-10	-2S	-21				-16	-14	-0622S	-174
AE369-8	-14S	-12	-3S	-4	222005-10C			-16	-16	-0622S	-190
AE369-10	-4S	-12	-4S	-6	222005-21C			-20	-18	-0630S	-239
AE369-12	-5S	-16	-5S	-8	222005-13C			-20	-20	-0630S	-280
AE369-16	-6S	-16	-6S	-27	222005-14C			-24	-24	-0648S	-320
AE369-20	-7S	-22	-7S	-10	222005-15C			-28	-30	-0648S	-381
AE369-24	-9S	-22	-9S	-12	222005-17C			-32	-32	-0648S	-445
AE369-32	-10S	-30	-10S	-14	222005-18C			-38	-42	-0648S	-572
AE369-40			-12S	-16	222005-19C			-54	-50	-0664C	
AE370-40				-16	222022-40C						
AE370-48				-17	222022-48C				-60	-0664C	
AE371-4	-2S	-10	-2S	-3				-16	-14	-0622S	-174
AE371-6	-3S	-12	-3S	-5				-16	-16	-0630S	-222
AE371-8	-4S	-12	-4S	-6				-20	-18	-0630S	-239
AE371-10	-5S	-16	-5S	-8				-20	-20	-0630S	-280
AE371-12	-6S	-16	-6S	-24				-24	-26	-0648S	-320
AE371-16	-7S	-22	-7S	-11				-28	-30	-0648S	-400

\*Sizes indicated are based on Hose-OD only. If sleeve is to be placed over fitting, a larger sleeve size may be required, depending on type of fitting used.

# Accessories & Equipment

## Coil, Sleeve & Clamp Chart

HOSE PART NUMBER	STEEL PROT. COIL SPRING*	PLASTIC COIL SLEEVE	STEEL PROT. COIL SLEEVE*	SUPPORT CLAMP	INTERNAL SUPPORT	INTERNAL SLEEVE	NYLON SLEEVE*	FIRESLEEVE*	FIRESLEEVE CLAMP	SUPPORT CLAMP	HEAVY DUTY SUPPORT CLAMP
	900564 (DASH SIZE)	900952 (DASH SIZE)	900705 (DASH SIZE)	900729 (DASH SIZE)	COIL	FF9700- (DASH SIZE)	FC425 (DASH SIZE)	624 (DASH SIZE)	FF9217 (DASH SIZE)	FF90311 (DASH SIZE)	
AE371-20	-8S	-30	-8S	-13				-38	-38	-0648S	-508
AE371-24	-10S	-30	-10S	-14				-40	-42	-0648S	-572
AE371-32	-11S	-30	-11S	-15				-54	-46	-0664C	-700
AE372-4	-1S	-6	-1S	-1				-12	-11	-0622S	-137
AE372-5	-12S	-8	-13S	-2				-12	-12	-0622S	
AE372-6	-2S	-10	-2S	-21				-16	-14	-0622S	-174
AE372-8	-14S	-12	-3S	-4		222005-10C		-16	-16	-0622S	-190
AE372-10	-4S	-12	-4S	-6		222005-21C		-20	-18	-0630S	-239
AE372-12	-5S	-16	-5S	-8		222005-13C		-20	-20	-0630S	-280
AE372-16	-6S	-16	-6S	-27		222005-14C		-24	-24	-0648S	-320
AE372-20	-7S	-22	-7S	-10		222005-15C		-28	-30	-0648S	-381
AE372-24	-9S	-22	-9S	-12		222005-17C		-32	-32	-0648S	-445
AE372-32	-10S	-30	-10S	-14		222005-18C		-38	-38	-0648S	-572
AE372-40			-12S	-16		222005-19C					
AE373-4	-2S	-8	-2S	-3				-16	-14	-0622S	-174
AE373-6	-3S	-12	-3S	-5				-16	-16	-0622S	-222
AE373-8	-4S	-12	-4S	-6				-20	-18	-0630S	-239
AE373-10	-5S	-16	-5S	-8				-20	-20	-0630S	-280
AE373-12	-6S	-16	-6S	-24				-24	-26	-0630S	-320
AE373-16	-7S	-22	-7S	-11				-28	-30	-0648S	-400
AE373-20	-8S	-30	-8S	-13				-38	-38	-0648S	-500
AE373-24	-10S	-30	-10S	-14				-38	-42	-0648S	-572
AE373-32	-11S	-30	-11S	-15				-54		-0648S	-700
AE373-08											
AE374-12	-6S	-16	-6S	-24				-24	-26	-0648S	-320
AE374-16	-7S	-22	-7S	-10				-28	-30	-0648S	-381
AE374-20	-8S	-22	-9S	-28				-32	-32	-0648S	-445
AE374-24	-10S	-30	-10S	-29				-38	-38	-0648S	
AE374-32	-10S	-30	-11S	-31				-54	-46	-0664C	-700
FC132-40						222022-40C					
FC132-48						222022-48C					
FC132-64							-64-262				
FC162-06	-2S	-12	-3S	-5					-18	-0622S	
FC162-08	-3S	-12	-4S	-6					-20	-0622S	
FC162-12	-5S	-16	-6S	-27					-24	-0648S	
FC162-16	-6S	-22	-7S	-11					-28	-0648S	
FC163-06											
FC163-08											
FC163-10											
FC163-12											
FC163-16											
FC163-20											
FC163-24											
FC163-32											

\*Sizes indicated are based on Hose-OD only. If sleeve is to be placed over fitting, a larger sleeve size may be required, depending on type of fitting used.

HOSE PART NUMBER	STEEL PROT. COIL SPRING* (DASH SIZE)	PLASTIC COIL SLEEVE (DASH SIZE)	STEEL PROT. COIL SLEEVE* (DASH SIZE)	SUPPORT CLAMP (DASH SIZE)	INTERNAL SUPPORT COIL	INTERNAL SLEEVE (DASH SIZE)	NYLON SLEEVE* (DASH SIZE)	FIRESLEEVE* 624 (DASH SIZE)	FIRESLEEVE CLAMP (DASH SIZE)	SUPPORT CLAMP (DASH SIZE)	HEAVY DUTY
FC173-06-82S	900564	900952	900705	900729		FF9700-	FC425		FF9217	FF90311	

# Assembly Equipment Hose Cut Off Equipment

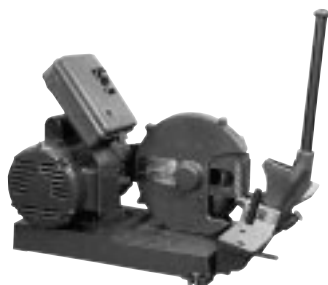

## S1104 Hose cut-off machine

### Hose Specifications

- ¥ Single and Double Wire Reinforced, 1/2 to 3 O.D.
- ¥ Four and Six Spiral Wire Reinforced, 1/2 to 1 1/2 O.D. with optional blades FT1101E1 and FT1101E2, spiral wire capacity is increased to 20

### Features

- ¥ Compact, 22 1/2 x 24 1/2
- ¥ Light, 130 lbs.
- ¥ Dual V-belt drive
- ¥ 10 1/2 cutting blade
- ¥ U.L. listed

### Electrical Requirements

- ¥ 3 hp, 230/460V, 3 phase, 60 Hz.
- ¥ Machine wired for 230V AC. Change connections as

shown on motor plate for 460V. Also, replace 230V motor heater with 460V motor heater included with machine.

### Ordering Instructions

#### Machine:

- S1104 Basic machine, 230/460V, 3 phase, 60 Hz
- S1026 Hose measuring gauge attachment
- FT1215 Hose reel attachment
- S1118 Coolant spray system (required when cutting spiral wire hose)
- SC1709 10 1/2 Replacement cutting blade
- SC1772 Welded steel table

\*A 3 hp, 230V AC, single phase machine is also available but not recommended because of reduced torque and less capability when cutting larger size hose. Order by part number S1104-230.

### Optional Cutting Blades

#### FT1101E1

10" Scalloped Blade



#### FT1101E2

10 1/2 Abrasive Blade

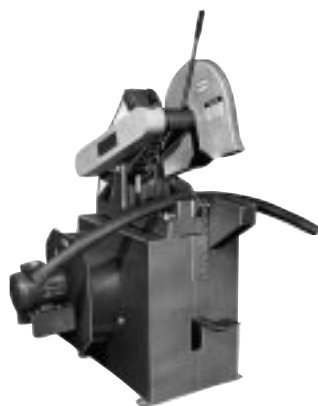
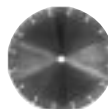

## FT1260 Hose cut off machine

### Hose Specifications

- ¥ All Hose Constructions 1/4" to 4" I.D.

### Features

- ¥ Built in safety features
- ¥ Easy to operate
- ¥ 16" abrasive wheel
- ¥ Heavy duty design
- ¥ Low maintenance
- ¥ V shaped vise
- ¥ U.L. listed

### Ordering Instructions

#### Machine:

- FT1260E1E1 Base machine with stand. 230/460V, 3 phase, 60 Hz
- FT1260E1E2 Base machine with stand and fume exhauster. 230/460V, 3 phase 60 Hz
- FT1260E1E3 Base machine with stand. 230V, single phase, 60 Hz
- FT1260E1E4 Base machine with stand and fume exhauster. 230V, single phase, 60 Hz

FT1260E2E5 Optional hood (can be used only with the E1E2 and the E1E4 models) Aeroquip recommends the use of FT1260E2E5, optional hood

#### Replacement Components:

FT1260E3E1 Replacement 16" fiberglass reinforced abrasive wheel

#### Electrical Requirements

Electrical requirements will vary depending on options selected.

Contact Eaton for additional information.

# Assembly Equipment Hose Cut Off Equipment



S1120  
Hose preparation package

Hose Specifications

Cutting 1/2" to 3"

Skiving 1/2" to 2"

Features

- ¥ Fast, efficient hose cutting
- ¥ 10" cutting blade
- ¥ Easily adjusted, self-contained skiving mandrels for reusable fittings
- ¥ Safe collection of skived rubber
- ¥ Spray system prolongs blade life
- ¥ Rotary hose reel for easy hose handling
- ¥ 24" x 42" x 24" 240 lbs.
- ¥ Double V belt cutting drive
- ¥ Direct skiving drive

Electrical Requirements

3 hp (in S1102 machine saw),  
1/3 hp (in dust collector),  
230/460V AC, 60 Hz, 3 phase

Blade Selection

Eaton offers three different cutting blades to make cutting of wire braid and spiral wire hose quick and easy.

Ordering Instructions

The S1120 hose preparation package may be ordered as a complete assembly or the five different components of the package may be ordered individually.

S1120\* Hose Preparation Package

S1102\* Includes: Basic Cut Off and Skiving Machine

S1043\* Dust Collector and Table

S1026 Hose Measuring Gauge Attachment

FT1215 Hose Reel Attachment

S1118 Coolant Spray System

SC1681 (Optional) Replacement Skiving Brush

\*A 3 hp 230V AC single phase motor is also available but not recommended due to reduced torque and less capability in cutting larger size hose. The following part numbers must be used when ordering components with single phase motors:

S1120230 Hose Preparation Package

S1102230 Basic Cut Off and Skiving Machine

S1043230 Dust Collector and Table



SC1709  
Standard replacement cutting blade (one included with each machine)



FT1101E1  
Scalloped cutting blade (optional; used for cutting spiral wire hose)

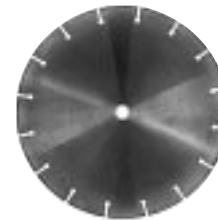

FT1101E2  
Abrasive cutting blade (optional; used for cutting spiral wire hose)

# Assembly Equipment Reusable Assembly Equipment

## FT1013 Portable reusable hose assembly machine

### Fitting Specifications

- Fabric and single wire braid, -04 through -40
- Double wire and 4-spiral wire, -04 through -32

### Features

- Quick acting wrench type chuck
- Easy to operate
- Safety guard
- Versatile
- Safety snap type switch
- Safety footswitch
- 36 rpm
- 45" x 56" x 46", 170 lbs.

### Ordering Instructions

- |            |   |
|------------|---|
| FT1013-1-5 | Base machine, 110V, with vise                                     |
| FT1013-1-6 | Base machine, 220V, with vise                                     |
| FT1013-1-3 | Base machine, 110V, with stand, vise and socketing tool           |
| FT1013-1-4 | Base machine, 220V, with stand, vise and socketing tool           |
| FT1013-1-1 | Base machine, 110V, with tool kit, stand, vise and socketing tool |
| FT1013-1-2 | Base machine, 220V, with tool kit, stand, vise and socketing tool |
| FT1013-2-1 | Vise  |
| FT1013-2-2 | Stand   |
| 1562       | Tool kit  |
| FT1281     | Socketing tool (see below)  |

### Electrical Requirements

1/2 hp reversible, variable speed, universal motor; as the torque increases the speed decreases. 110V AC, single phase, 25-60 Hz, or 220V AC, single phase, 25-60 Hz



## FT1281 Socketing tool

For use with stand mounted FT1013 and FT1097 Portable Hose Assembly Machine. (The FT1281 socketing tool must be accompanied by the FT1097-2-1 vise kit (see page 000) when used on the FT1097 portable hose assembly machine).

# Assembly Equipment Reusable Assembly Equipment



FT1028  
Production reusable hose  
assembly machine

¥ 24Óx 62Óx 32Ó550 lbs.

Electrical Requirements  
220/440V, 3 phase, 60 Hz

### Fitting Specifications

- ¥ Screw together fittings Ñ Fabric or wire braided hose up to E82
- ¥ Screw together fittings Ñ 4 spiral wire hose up to E24

### Ordering Instructions

- FT1028D1E1 Base machine with hand operated drum switch
- FT1028D1E2 Base machine with hand operated drum switch and legs
- FT1028D1E4 Base machine with push button control and legs
- FT1028D1E5 Base machine with automatic stop and spindle control

### Features

- ¥ High volume production
- ¥ Ideal for 2 or 3 piece fittings
- ¥ 4 speed transmission; 90 rpm, 120 rpm, 210 rpm, 400 rpm
- ¥ Easy to operate
- ¥ Micrometer stop
- ¥ Electric brake
- ¥ U.L. listed

### FT1234 Drop-in socket holder

FT1234 drop-in socket holder is designed for the FT1028 assembly machine. They prevent rotation of the socket during assembly and provide a back stop to ensure consistent location of the socket.



AEROQUIP PART NO FT1234	HEX SIZE (IN.)	HOSE STYLE	SOCKET PART NUMBER AND SIZE
E100	9/16	280E4	120E4
E101	9/16	280E5, 150E4, FC3E04, FC3E04, FC3E04, FC3E04	120E5, 121E4
E102	1 1/16	280E6, 150E5, FC3E05, FC3E05, FC3E05, FC3E05	120E6, 121E5
E104	1 3/16	150E6, 150E4, FC3E06, FC3E06, FC3E06, FC3E06	121E6, 401E4
E105	7/8	280E8	120E8
E106	1 1/8	150E8, FC3E08, FC3E08, FC3E08, FC3E08	121E8
E200	1	280E10	120E10, FC3E10, FC3E10
E201	1	FC1E6, 150E6, 150E6, FC1E6, 150E6, 150E6	400E6, 401E6, 401E6
E202	1 1/8	150E10, 150E8, 150E8, FC3E10, FC3E10, FC3E10, FC3E10	401E8
E203	1 1/8	280E12	120E12
E204	1 1/8	150E12, 150E10, FC3E12, FC3E12	121E12, 401E10
E205	1 1/8	280E16	121E16, FC3E14-16
E206	1 1/8	150E16, FC3E16, FC3E16, FC3E16, FC3E16	121E16
E207	1 1/8	FC1E12, 150E12	400E12, 401E12
E208	1 1/8		FC3E1E20
E209	1 1/8	150E20, FC3E20	121E20

### FT1033 Assembly mandrels

The FT1033 assembly mandrels are exclusively designed for use with the FT1028 assembly

machine. Secured in the chuck they speed the volume production of Aeroquip three piece reusable hose fittings.

PART NUMBER	FITTING NUMBER	PART NUMBER	FITTING NUMBER
FT103E1	FC92E404	FT103E2	41E5, 40E5
FT103E2	FC92E504	FT103E3	40E6
FT103E3	FC92E808	FT103E4	41E6
FT103E4	FC92E506	FT103E5	41E8, 40E8
FT103E5	FC92E1010	FT103E6	41E10, 40E10
FT103E6	FC92E606	FT103E7	40E12
FT103E7	FC92E1012	FT103E8	41E12
FT103E8	FC92E606	FT103E9	40E16
FT103E9	FC92E1012	FT103E10	41E16
FT103E10	FC92E1016	FT103E11	41E16
FT103E11	FC92E2020	FT103E12	40E20
FT103E12	FC92E2020	FT103E13	41E20
FT103E13	FC92E204, FC92E404, FC92E404	FT103E14	40E24
FT103E14	FC92E406, FC92E606	FT103E15	41E24
FT103E15	FC92E608, FC92E808	FT103E16	40E32
FT103E16	FC92E810	FT103E17	41E32
FT103E17	FC92E1012	FT103E18	41E32, 41E32, 41E32
FT103E18	FC92E1016	FT103E19	41E32, 41E32, 41E32
FT103E19	FC92E2020	FT103E20	41E32, 41E32, 41E32
FT103E20	41E4, 40E4	FT103E21	41E32, 41E32, 41E32
FT103E21	41E4, 40E4	FT103E22	41E32, 41E32, 41E32
FT103E22	41E4, 40E4	FT103E23	41E32, 41E32, 41E32
FT103E23	41E4, 40E4	FT103E24	41E32, 41E32, 41E32
FT103E24	41E4, 40E4	FT103E25	41E32, 41E32, 41E32
FT103E25	41E4, 40E4	FT103E26	41E32, 41E32, 41E32
FT103E26	41E4, 40E4	FT103E27	41E32, 41E32, 41E32
FT103E27	41E4, 40E4	FT103E28	41E32, 41E32, 41E32
FT103E28	41E4, 40E4	FT103E29	41E32, 41E32, 41E32
FT103E29	41E4, 40E4	FT103E30	41E32, 41E32, 41E32
FT103E30	41E4, 40E4	FT103E31	41E32, 41E32, 41E32
FT103E31	41E4, 40E4	FT103E32	41E32, 41E32, 41E32
FT103E32	41E4, 40E4	FT103E33	41E32, 41E32, 41E32
FT103E33	41E4, 40E4	FT103E34	41E32, 41E32, 41E32
FT103E34	41E4, 40E4	FT103E35	41E32, 41E32, 41E32
FT103E35	41E4, 40E4	FT103E36	41E32, 41E32, 41E32
FT103E36	41E4, 40E4	FT103E37	41E32, 41E32, 41E32
FT103E37	41E4, 40E4	FT103E38	41E32, 41E32, 41E32
FT103E38	41E4, 40E4	FT103E39	41E32, 41E32, 41E32
FT103E39	41E4, 40E4	FT103E40	41E32, 41E32, 41E32
FT103E40	41E4, 40E4	FT103E41	41E32, 41E32, 41E32
FT103E41	41E4, 40E4	FT103E42	41E32, 41E32, 41E32
FT103E42	41E4, 40E4		

# Accessories & Equipment

## Assembly Equipment

FT1211  
Dogleg assembly machine

### Features

- ¥ Full set of jaw inserts to accommodate -3 through -48 size fittings
- ¥ Easy-to-use hand crank and angle locator for setting precise phase angles
- ¥ Built-in tolling storage cabinet
- ¥ Forward, reverse and neutral operation options
- ¥ Sturdy steel frame with bolt-down base
- ¥ Sliding guard for operator safety

### Specifications

Weight: 800 lbs. (without attachments)

Speed: 45 rpm

Motor: 1.5 hp

Spindle Thru-Hole: 7.75 inches

Power: Standard 115-volt, single phase, 60-Hz, 30-amp breaker required

### Part Numbers

FT1211A Base Machine (includes tooling for -3 through -48 size fittings)

FT1211-23 Faceplate (for straight captive flange fittings)

FT1229-No Stripping Tool

FT1230-No Stripping Tool

222070 Assembly Lube

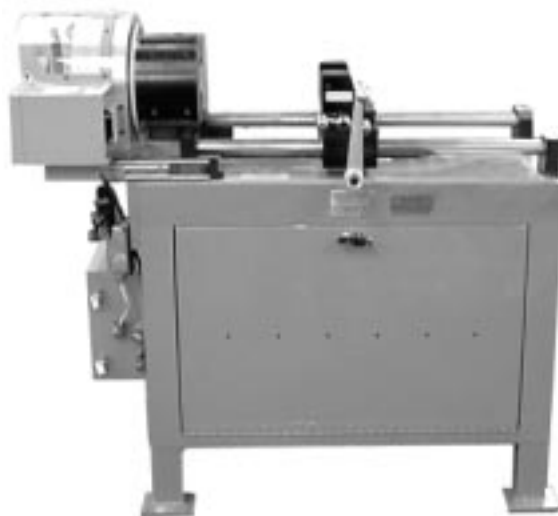

FT1220E10  
Reusable fitting assembly mandrels



### Specifications

The FT1220E10 kit includes all assembly mandrels listed for E4 through E20 for the assembly of Aeroquip 411, 401, and 406 reusable hose fittings. Individual mandrels may also be ordered by using the part numbers to the right.

THREAD TYPE	SAE 37 j (JIC)	SAE 45 j	PTT 30 j
USE WITH FITTING NOS.	411	401	406
DASH SIZE			
E4	158E4S	158E4S	
E5	158E5S	158E5S	
E6	58E6S	158E6S	
E8	158E8S	158E8S	
E10	158E10S	158E10S	
E12	58E12S	158E12S	
E16	156E16S		156E16S
E20	156E20S		156E20S
E24	156E24S		156E24S
E32	156E32S		
KIT PART NUMBER	FITTING PART NUMBER	THREADTYPES	SIZE RANGE
1562 (not shown)	401, 406, 411, 412	SAE 45 (JIC), PTT, NPTF	E4 through E32
1597 (not shown)	401, 412	SAE 45 NPTF	E4 through E12
1598 (not shown)	411, 412	SAE 37 (JIC), NPTF	E4 through E32
1599 (not shown)	411, 412	SAE 37 (JIC), NPTF	E4 through E12
FT1220E10 (not shown)	401, 406, 411, 412	SAE 45 (JIC), PTT, NPTF	E4 through E20

# Accessories & Equipment

## Assembly Equipment

### 1605 & 1606 Assembly Tool Kits

The 1605 and 1606 Assembly Tool Kits contain the 1583 assembly tool and accessory items necessary to assemble banded segment socket fittings. The 1605 Kit provides tooling for assembly of both 3 segment (sizes -20 thru -32) and 4 segment (sizes -40 and -64) fittings. The 1606 Kit provides tooling only for assembly of 3 segment fittings. Component parts may be ordered individually as needed.



### 1605 KIT (-20THRU -64 HOSE FITTINGS)

PART NO.	DESCRIPTION	QUANTITY
1583-64	Assembly Tool	1

### FT1229/FT1230 Hose Cover Stripping Tools

The Eaton Aeroquip FT1229 and FT1230 hose cover stripping tools are designed to remove the rubber cover from wire reinforced hose prior to attaching crimped or reusable fittings. The tools are designed for use either in a standard shop vise, lathe chuck, drill press, Aeroquip assembly machine or by hand.

The mandrels are color-coded for easy identification; FT1229 for reusable fittings silver cadmium plated, FT1230 for crimp fittings yellow chromate plated. Each tool is assembled and preset for the particular size hose. If desired, components may also be ordered separately.

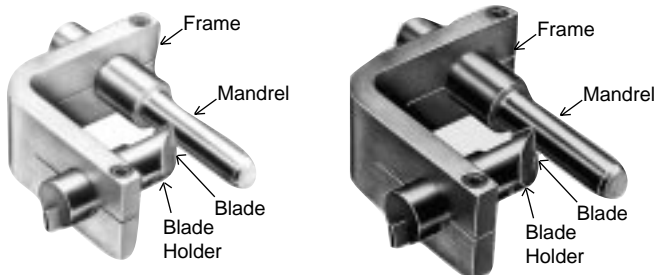

# Accessories & Equipment Assembly Equipment

Hose assembly machines

## FT1212 and FT1222 Segmented Fitting Assembly Machine

The FT1212 Assembly Machine shown above provides fast, easy assembly of 3 segmented socket type fittings.

The FT1212 Assembly machine can be bench mounted or transported making it ideal for virtually every segmented socketed assembly operation.

The FT1222 Assembly Machine is also available for assembly of 4 segmented socket type fittings.

The unique design of the FT1222 assembly machine develops over 10 tons of force on each socket segment while exerting only minor forces on the frame.

The light weight, durability of the machine can be bench mounted or transported, making it ideal for segmented socket fitting assembly operations using Aerquip hose styles 150901 and 2662 in sizes -40, -48, and -64.

For more information contact Eaton.



## Components

1. Sturdy tubular steel frame
2. Single acting spring return cylinders
3. Pressure gauge
4. Pump
5. Electric foot switch
6. Locating pins
7. Adapter pads

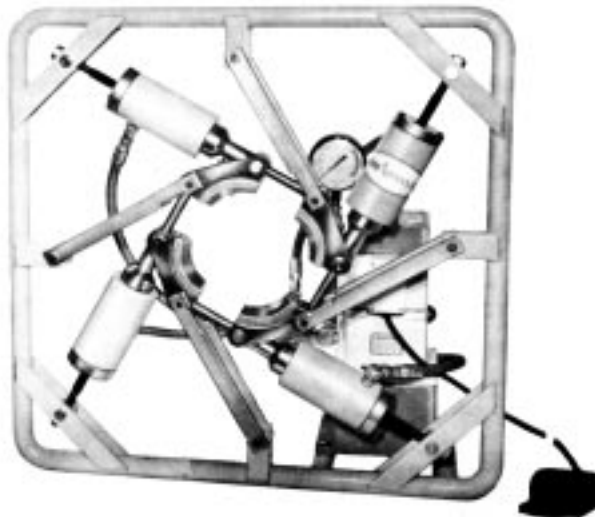

# Assembly Equipment Hose Proof Stand

FT1312  
Hose proof test stand

Hose Specifications  
Assembles up to 2" I.D., 6  
spiral wire

Features

- ¥ Designed to use tap water, eliminating the need for a special test fluid
- ¥ Compact power unit is air driven
- ¥ Air regulator and gauge provide easy pressure adjustment and monitoring
- ¥ Tough transparent Lexan\* lid
- ¥ 79" x 36" x 53" 550 lbs.

Power Unit

The power unit of the FT1312 tester is a compact, economical air driven hydraulic pump. It will provide sufficient hydraulic pressure to proof test any Aeroquip hose assembly, up to 22,000 psi.

\*Lexan is a General Electric trademark.



FT1312 and FT1261  
Standard adapter selection chart

HOSE FITTING* STYLE AND SIZE	FITTING ADAPTER PART NUMBER	PRESSURE PORT ADAPTER PART NUMBER	PLUG OR CAP PART NUMBER
<b>SAE 37i (JIC) SWIVEL</b>			
D4	2027D8D4S	**	900599D4
D5	2021D6D5S	2081D12D6S	900599D5
D6	2027D8D6S	**	900599D6
D8	2027D8D8S	**	900599D8
D10	2027D10D8S	**	900599D10
D12	2027D8D12S	**	900599D12
D16	2021D12D16S	**	900599D16
D20	2021D16D20S	2040D12D16S	900599D20
D24	2021D16D24S	2040D12D16S	900599D24
D32	2021D16D32S	2040D12D16S	900599D32

<b>SAE 45 i SWIVEL</b>			
E4	2006E4B	208D1E6S	900599E4
E5	2006E5B	208D1E6S	900599E5
E6	2006E6B	208D1E6S	2006E6B, 208E6S
E8	200D1E8B	**	900599E8
E10	200D1E10B	**	900599E10
E12	200D1E12B	**	2008E12B, 208E2S

<b>MALE PIPE</b>			
E2	208D8E2S	208D1E8S	204D2E2S, 208E2S
E4	208D8E4S	208D1E8S	204D4E4S, 208E4S
E6	208D8E6S	208D1E8S	204E6S, 208E6S
E8	208D8E8S	**	204E8S, 208E8S
E12		**	204E12S, 208E12S
E16	204D1E16S	**	204E16S, 208E16S
E20	204D1E20S	204D1E16S	204E20S, 208E20S
E24	204D2E24S	204D1E16S, 204D1E20S	204E24S, 208E24S
E32	204D2E32S	204D1E16S, 204D1E20S, 204D2E24S	204E32S, 208E32S

\*Two adapters are required per hose assembly to be tested.

\*\*Internal Skive Fittings Only.

FT1261  
Hose proof test stand

Hose Specifications  
Assembles up to 2" I.D., 6  
spiral wire in 50 ft. coil lengths

Features

- ¥ Designed to use tap water, eliminating the need for a special test fluid
- ¥ Air regulator and gauge provide easy pressure adjustment and monitoring
- ¥ Tough transparent Lexan\* lid
- ¥ 96" x 84" x 54" 800 lbs.

Power Unit

The power unit of the FT1261 tester is a compact, economical air driven hydraulic pump. It will provide sufficient hydraulic pressure to proof test any Eaton Aeroquip hose assembly, up to 22,000 psi.

\*Lexan is a General Electric trademark.



# Assembly Instructions

## Installation Instructions for 624 Firesleeve



The 624 Firesleeve is constructed of a single layer of braided fiberglass tubing impregnated with flame-resistant silicone rubber. The primary applications for

this sleeve are on hose assemblies conveying a flammable fluid in a system that could be exposed to a direct flame or to protect any hose passing through a high tem-

perature area. Typical applications include fuel and lube lines in USCG inspected ships. Numerous single wire braid hose styles (2651 for example) when covered with

624 firesleeve are deemed fire-resistant by the U.S. Coast Guard.

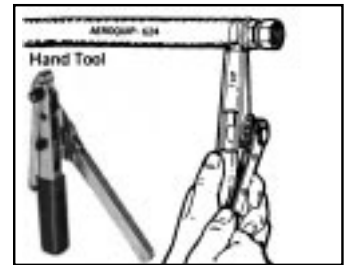
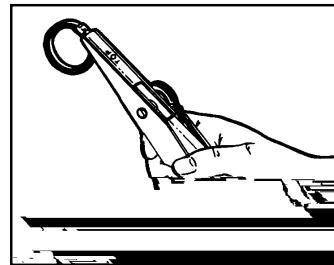
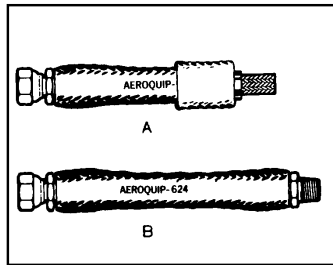
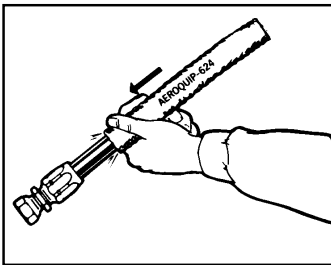

1. Follow the appropriate hose assembly instructions through the assembly of one end fitting. Cut firesleeve to same length as hose.

Using Firesleeve End Dip (AE13702-001), dip ends of firesleeve to a depth of three quarters of an inch and allow to dry at room temperature.

Start firesleeve over cut end of hose. Note: If applying sleeve over PTFE or stripped cover assemblies, wrap exposed wire with tape. Grasp sleeve and slip over the hose assembly, as illustrated.

2. Skin sleeve back from cut end of hose enough to allow assembly of second end fitting. (2A)

Then center sleeve so that it completely covers both sockets. (2B)

3. Insert tail of band clamp (FF9217-) (see page 000 for part number and dash size) into hand clamping tool.

4. Position band clamp over sleeve as shown and then draw tight with hand tool, F2636. Remove tool and cut free end of band clamp. Repeat on other end of assembly.

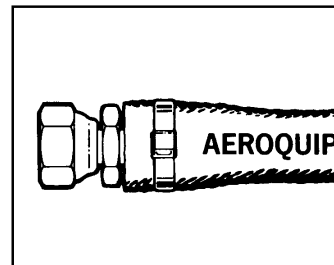

5. To complete, bend protruding tail of clamp over clamp buckle. Also, repair any scuffs or minor abrasions of firesleeve by brush application of End Dip AE 13702-001.

Clean, Inspect and Proof Test

CAUTION: Do Not Pass With Air Under Water.

Aeroquip End Dip  
Part Number AE13702-001

# Assembly Instructions

## Internal Support Coils, 222005, 222022, FF90505

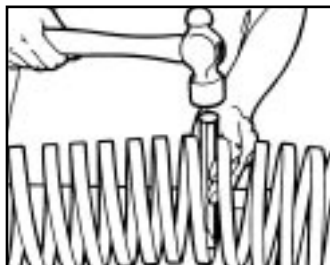

### Step 1

Cut coil length. The coils should be cut to the hose length, minus the nipple intrusion. For any given hose assembly the support coil length equals the overall hose assembly length minus the sum of the overall lengths of each end fitting (O.D. dimensions).

Small size of the coil can usually be cut with strap cutters or sheet metal shears. The larger sizes are best cut with a heavy sharp chisel or bolt cutter. With small sizes, skip directly to Step 3.



### Step 2

Compress the coil (large sizes only). It is necessary to reduce the coil diameter slightly in order to insert it into the hose. The easiest approach is to use a length of pipe with a notch cut in one end. Clamp the plain end of the pipe in a vise, slide the coil over the pipe and insert the free end of the coil into the notched end of the pipe. Then clamp the coil and pipe firmly together. Twist the coil to compress it prior to installation into the hose.

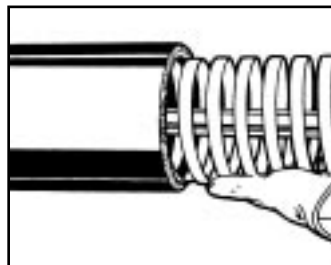

### Step 3

Small sizes: The coil can be worked into the hose by hand without difficulty. Remove all burrs from the coil prior to insertion. This will prevent cutting of the hose tube. Position the coil mid-way between hose ends.

Large sizes: With the pipe still in position, as in Step 2, assemble the hose over the coil. With the coil fully centered in the hose, remove the pipe and clamp.

Recommended for vacuum service with nitrile hose. 222005, 222022-C are stainless steel.

MONEL K-50 PART NUMBER	COIL O.D. (INCHES)
FF90505-0809	0.81
FF90505-1092	1.09
FF90505-1375	1.38
FF90505-1619	1.62
FF90505-2157	2.16
FF90505-0695	0.70
FF90505-0969	0.97
FF90505-1250	1.25
FF90505-1499	1.50
FF90505-1969	1.97
FF90505-2671	2.67
FF90505-3266	3.27

STAINLESS STEEL PART NUMBER	COIL O.D. (INCHES)
222005-10C	0.42
222005-11C	0.60
222005-13C	0.73
222005-14C	0.94
222005-15C	1.19
222005-17C	1.44
222005-18C	1.88
222005-19C	2.44
222005-21C	0.51
222005-23C	0.34
222005-32C	1.97
222005-40C	2.67
222005-48C	3.27
222005-64C	4.28

# Assembly Instructions

## Installation Instructions for Internal Support Sleeve FF9700

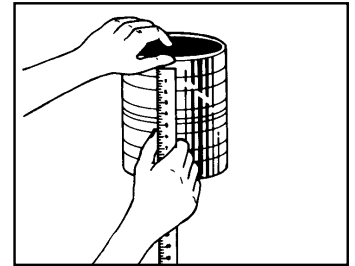
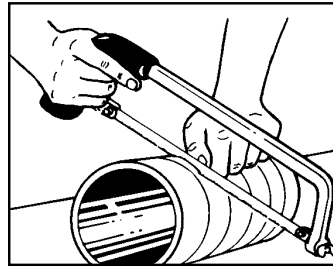
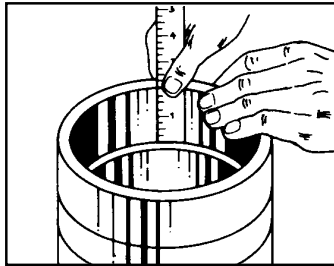
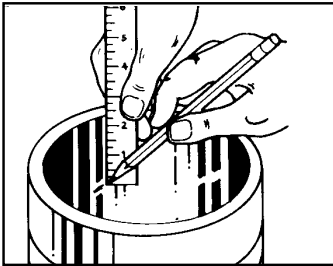

1. Cut hose to required length and assemble one end fitting.
2. On the remaining fitting, measure the distance from the end of the nipple to the nipple shoulder, add 1/4" to this dimension and mark this distance on the inside of the hose.

3. Install internal support sleeves up to, but not past the mark and no more than 3/8" below the mark.
4. Measure the distance from the end of the last sleeve section to the mark. If this dimension is greater than 3/8", one or possibly two sleeves must be cut to obtain the optimum supported length within the hose.

5. One Sleeve Cut
  - a. Cut sections of sleeve must contain at least two bronze rings. If the sleeve section needed is greater than 3/8" in the dimension chart, make a clean, straight cut in the area between the rib indicators where stenciling is present (with a hacksaw or band saw).
  - b. Make sure the cut section is free of foreign particles and rubber dust.

6. Two Sleeve Cuts
  - a. If the cut section needed is less than dimension 3/8" add the measured distance in Step 4 to the length of one sleeve, and make cuts in two sleeves so their total length will equal this distance. Remember, neither cut section can be less than dimension 3/8" because no cut section should contain less than two bronze rings. Cuts must be made between the rib indicators where stenciling is present.
  - b. Complete the installation following 3/8" and 3/8" in Step 5.
7. Assemble the other end fitting to the hose.

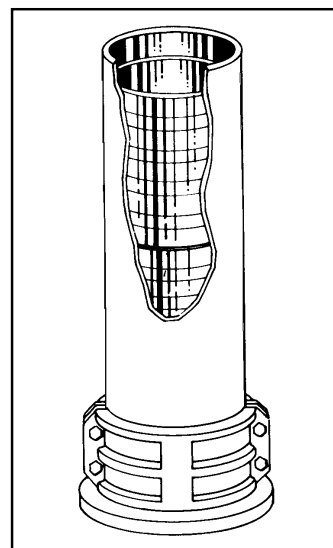

- c. Make sure a full sleeve is at each end of the hose assembly by placing the cut section below the last full section installed in the hose.

# Assembly Instructions

## Stripping the Cover for Hose FC162, FC163, AE373, AE371

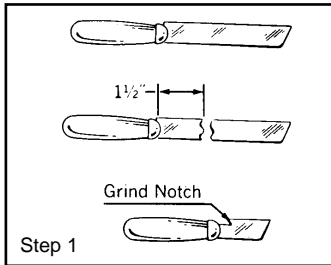

1. By Hand: break off and grind smooth the blade of a leather knife as shown. Grind notch where blade enters handle and sharpen rear edge of notch. Keep knife sharp for easy stripping.

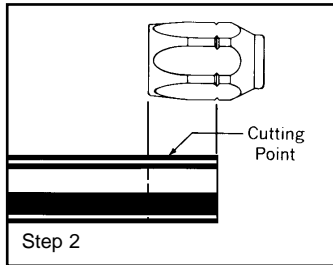

2. Use notch on socket to determine length of cover to be stripped.

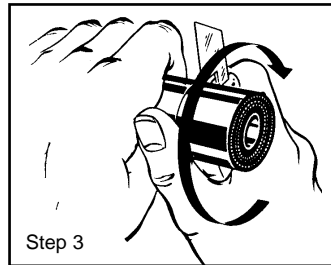

3. Cut around hose through cover to wire braid. Use sharpened rear edge of knife as shown.

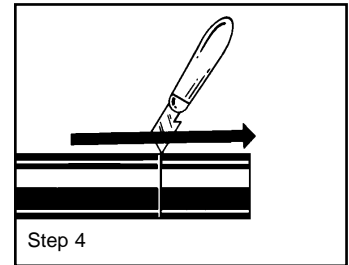

4. Slit cover lengthwise. Be sure cut is down to wire braid.

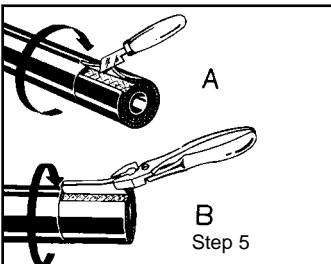

5. Working clockwise, pry up cover as shown (A), twist off cover with pliers (B).

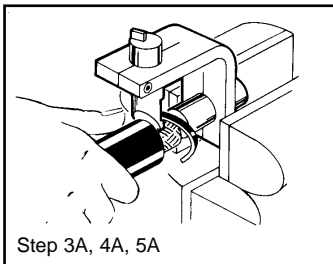

Option Step 3A, 4A, 5A.  
Skive Tool:  
Use the correct size Eaton Aeroquip FT1229 hose cover skiving tool. Mount the tool in a vise. Push the hose over the mandrel. Rotate the hose clockwise until it bottoms or secure hose in a vise and attach FT1279 auger to the skive tool. Insert mandrel into the hose and rotate clockwise until it bottoms.

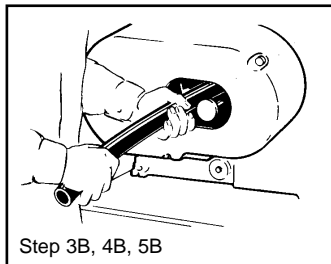

Option Step 3B, 4B, 5B.  
Machine:  
Use the Eaton Aeroquip S1102 cut-off and skiving machine. Consult the owners manual. Select the correct mandrel. Turn on the machine. Put the hose over the mandrel and rotate.

# Assembly Instructions

## Hose 2556, 2565



To determine  $L$  length (length of hose): from  $OA$  length (overall length) deduct  $D$  dimensions of both end fittings and add 1/2 inch, as the hose tends to shorten when fittings are inserted.



### Assembly

1. Cut hose to required length with a sharp knife. Oil inside of hose and outside of nipple liberally. Use Aeroquip 222070 hose assembly lube or heavy oil.

Note: Where oil cannot be used for lubrication, a liquid soap may be used.

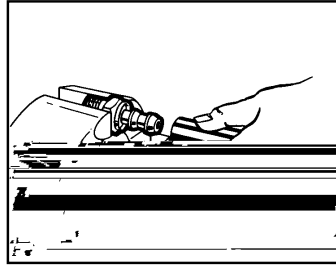

2. Tighten nipple in vise as shown. Push hose on fitting until hose end bottoms underneath protective cap. For quantity production use an Aeroquip Socketless fitting assembly machine. Clean, Inspect and Proof Test.

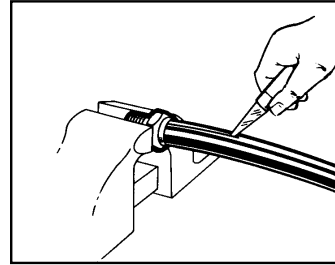

### Disassembly

3. With a sharp knife, slit hose lengthwise from protective cap to end of nipple. Be careful not to damage the nipple.

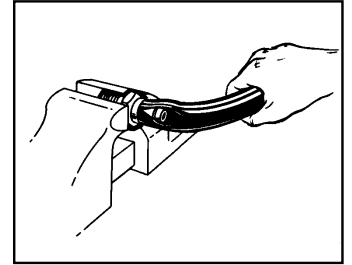

4. Bend hose, then snap hose off with a quick tug.



### Hose Assembly Lube

A specially compounded lubricant superior to any other lubricant used in hose assembly work. Available in pints or gallons.

Use for either hand or machine assembly.

NOTE: Not to be used with green cover fire resistant hydraulic fluid hoses.

Part Numbers: pint 222070,  
gallon 222070-8.

# Assembly Instructions

Hose FC234,  
AE372, 302A,  
303, AE369,  
AE370

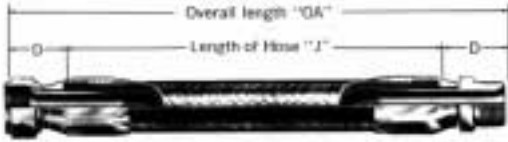

To determine "J" length (length of hose): from "OA" (overall length) deduct "D" dimensions of both end fittings.

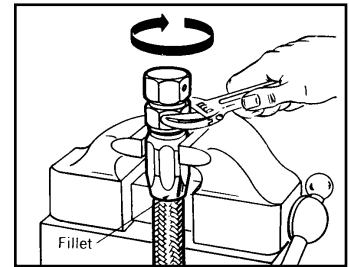
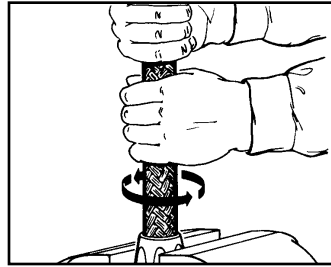
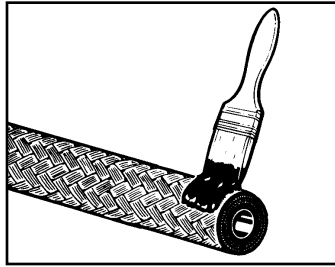
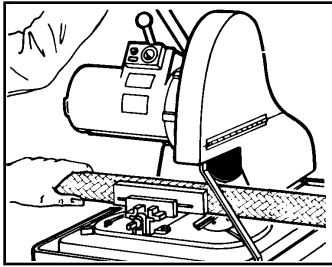

1. Cut hose squarely to desired length using a high speed abrasive wheel or steel cut off wheel. Hose may also be cut with a fine toothed hacksaw or an Aeroquip Cut-off Machine (S1104, FT1260, S1120, page 153-154). Hose should be bent so that the outside of the bend contacts the wheel to prevent binding. Do not feed the hose to the cutting edge too fast as it may tend to loosen the wire reinforcement or cause unraveling. After the cutting operation is complete, thoroughly clean all residue from the inside and outside of the hose.

If cutting the hose has caused the end to neck down slightly, it can be flared with a smooth tool to allow proper insertion of the nipple.

2. Apply thin coat of end sealing compound to the ends and to the cover which will be covered by the fitting socket, and allow to dry for about 1/2 hour. Do not allow end sealant to enter hose bore.

Immediately before installing socket, apply a second thin coat of end sealing compound over the first thin coat.

3. Put fitting socket in vise and screw hose counterclockwise into the socket until hose bottoms, then back off 1/4 turn.

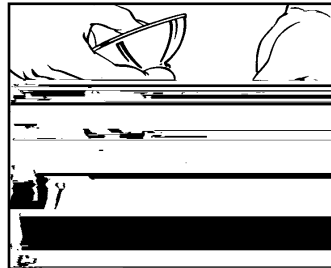

4. Oil nipple threads and inside of hose liberally with a petroleum base oil such as Aeroquip LUBE 222070. Use Molykote Gn Paste

5. a. For male end fittings insert assembly mandrel into nipple. Screw nipple clockwise into socket. Tighten nipple to within 1/32" to 1/16" of the socket. Do not tighten against socket.  
b. For swivel end fittings (Aeroquip styles 401 and 411) insert mandrel into nipple and tighten nut onto mandrel. Screw nipple into socket and hose clockwise using wrench on assembly mandrel hex. Leave 1/32" to 1/16" clearance between nut and socket so that nut can swivel freely.

NOTE: An assembly mandrel is required (see page 000) for all single wire braid hose in sizes 1/4" through 3/4" except when 4400 series fittings are used. For sizes 1" and larger using adapter to provide a hex surface for screwing the nipple into the hose and socket.

6. Remove assembly mandrel and add a fillet of sealing compound to hose end of socket. Clean, Inspect, and Proof Test.

INSTRUCTIONS FOR ASSEMBLY OF MONEL AND STAINLESS STEEL FITTINGS, see page 000.

# Assembly Instructions

## 2580 Hose and Fittings -4 thru -32 with Standard Reusable Fittings

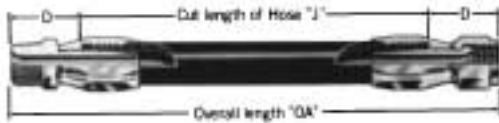

To determine "J" length (length of hose): from "OA" (overall length) deduct "D" dimensions of both end fittings.

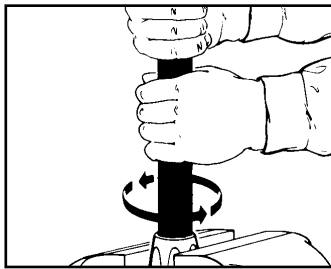

1. Cut hose square with knife or cut-off wheel. Clean hose bore. Put socket in vise and screw hose counterclockwise into socket until it bottoms. Back off 1/4 turn.

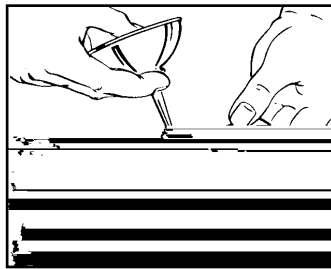

2. Oil nipple threads, assembly tool mandrel, and inside of hose **LIBERALLY**. Use heavy oil or Aeroquip Lube Oil.

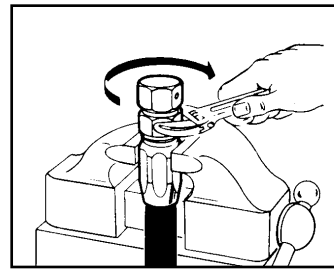

3. **MALE ENDS:** Push assembly tool into nipple. Oil. Screw nipple clockwise into socket and hose. Tighten nipple leaving 1/32" to 1/16" clearance between nipple hex and socket.

**SWIVEL ENDS:** Tighten nipple and nut on assembly tool. Oil. Screw nipple clockwise into socket and hose. Leave 1/32" to 1/16" clearance between nut and socket.

# Assembly Instructions

## Attaching the fitting for Hose 2766, FC162, FC163, AE373, AE371

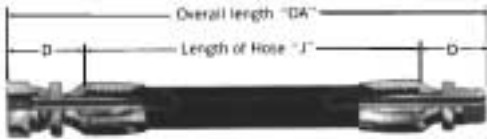

To determine "J" length (length of hose): from "OA" (overall length) deduct "D" dimensions of both end fittings.

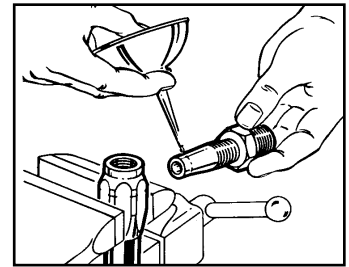
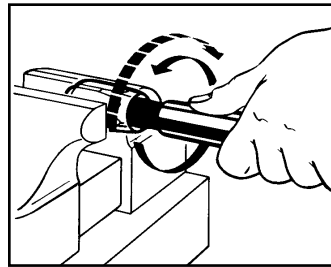
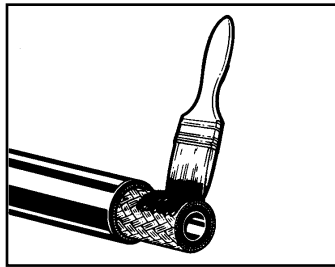
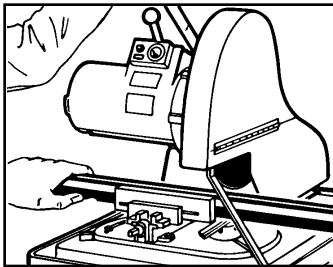

1. Cut hose squarely to desired length using a high speed abrasive wheel or steel cut off wheel. Hose may also be cut with a fine toothed hacksaw or an Aeroquip Cut-off Machine (S1104, FT1260, S1120 page 153-154). Hose should be bent so that the outside of the bend contacts the wheel to prevent binding. Do not feed the hose to the cutting edge too fast as it may tend to loosen the wire reinforcement or cause unraveling. After the cutting operation is complete, clean all residue from the inside and outside of the hose.

If cutting the hose has caused the end to neck down slightly, it can be flared with a smooth tool to allow proper insertion of the nipple.

2. Strip off Cover (see page 164)

3. Apply coating of sealing compound to ends of hose and to skived portion to cover all exposed wire surfaces and wire ends, and allow to dry for about one half hour. Do not allow end sealant to enter hose bore. Immediately before installing socket, apply a second coat of sealing compound over the first coat.

4. For multiple wire braid reinforced hose, except sizes -16, -24, -32 (FC163, AE371) place fitting socket in a vise and screw hose counter-clockwise into the end of socket until it bottoms.

For spiral reinforced hose and multiple wire braid reinforced hose, sizes -16, -24, and -32, place hose in vise and push socket onto it while rocking and twisting socket until it bottoms onto the hose. After starting the socket onto the hose it may be tapped on with a rawhide or lead hammer to avoid damage to the threads.

5. Oil nipple threads and inside of hose liberally with a petroleum base oil such as Aeroquip LUBE 222070. Use Molykote Type G for monel fittings.

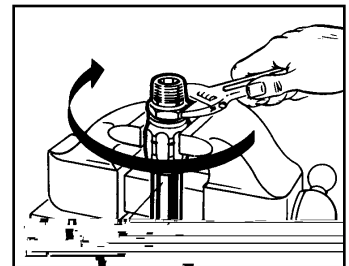

6. Screw nipple clockwise into socket and hose. Leave a  $\frac{1}{32}$ " to  $\frac{1}{16}$ " clearance between the nipple hex and the socket. Place a fillet of sealing compound around the hose end of the socket and the hose.

# Assembly Instructions

## For PTFE Hose Ø 2807, 2808

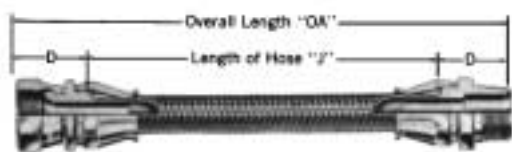

To determine "J" length (length of hose): from "OA" (overall length) deduct "D" dimensions of both end fittings.

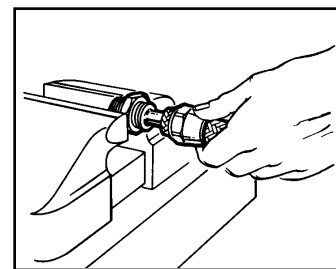
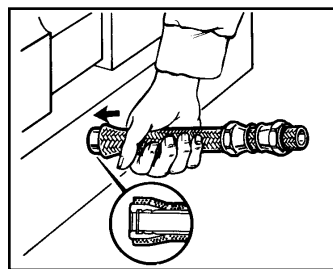
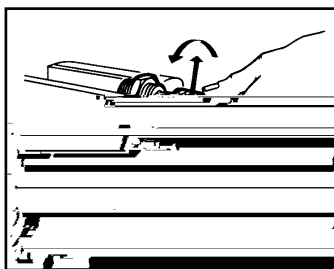
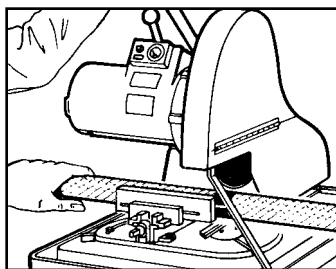

### To Assemble

1. Wrap hose with masking tape at cut-off point and cut squarely to length through taped area using a high speed abrasive wheel, a sharp cut-off wheel or a fine toothed hacksaw. Remove tape and trim any loose wires flush with tube stock. Any burrs on the bore of the tube stock should be removed with a knife. Sometimes wire braid will tend to "neck down" on one end and "flare out" on the opposite end. This is characteristic of wire braid hose and can be used to an advantage in the assembly of the fittings. Slip two sockets back-to-back over the "necked down" end of hose, positioned approximately 3 inches from each end.
2. Grip nipple hex in a vise. Work the hose bore over the nipple to size the tube and aid in separating the braid prior to inserting the sleeve. Remove hose from nipple.
3. Push the sleeve over the end of the inner tube and under the wire braid by hand. Complete positioning of the sleeve by pushing the hose end against a flat surface. Visually inspect to see that the tube stock butts against the inside shoulder of the sleeve. Set the sleeve barbs into the PTFE tube by pushing a tapered punch into the end of the sleeve and tube. This step can be facilitated by using Aeroquip PTFE Hose Assembly Tool Kit Part Number FT1081.

# Assembly Instructions

For hose assemblies with band type Segmented Socket Fittings  $\text{\textcircled{D}}$  for Hose AE370, AE374, 150901



To determine "J" length (length of hose): from "OA" (overall length) deduct "D" dimensions of both end fittings.

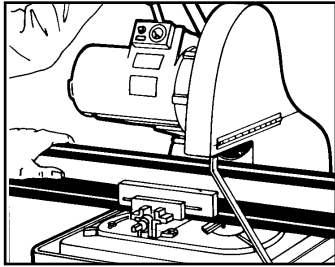

1. Cut hose squarely to desired length using a high speed abrasive wheel or steel cut off wheel. Hose may also be cut with a fine toothed hacksaw or an Aeroquip Cut-off Machine (S1104, FT1260, S1120) **page 153-154** hose should be bent so that the outside of the bend contacts the wheel to prevent binding. Do not feed the hose to the cutting edge too fast as it may tend to loosen the wire reinforcement or cause unraveling. After the cutting operation is complete, clean all residue from the inside and outside of the hose.  
If cutting the hose has caused the end to neck down slightly, it must be flared out to allow proper insertion of the nipple. An open end wrench can be used to flare the hose out.

2. Apply thin coat of end sealing compound to the hose ends and to the outer cover which will be covered by the fitting socket, and allow to dry for about 1/2 hour. Immediately before installing nipple, apply a second thin coat of end sealing compound over the first thin coat. Do not allow end sealant to enter hose bore.

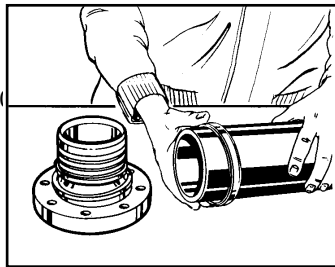

3. Place retaining ring over nipple and segment band over hose. In case of flanged ends, be sure the flange is in place on the nipple before putting retaining ring on and inserting nipple into hose. Push nipple all the way into hose until stopped by nipple shoulder.



4. Hook socket segments into retaining ring and space segments evenly around hose. Place assembly tool around segments so the locating pins of the tool fit the corresponding hoses in each segment. Make sure locating pins are tight in assembly tool before proceeding.

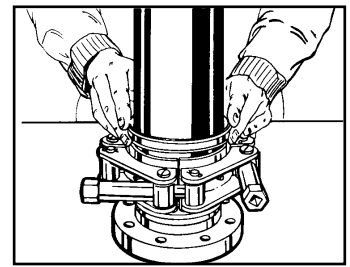

b. The convex inner surface of the band must seat squarely into the grooves of the segments. Do not compress segments more than necessary to slip the securing band in place over the segments. If necessary, the band may be tapped lightly into place with a plastic or rubber mallet.

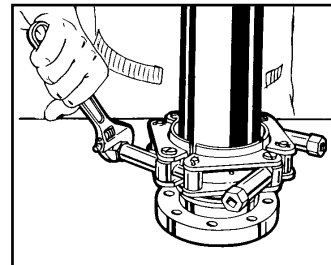

5. a. Alternately and uniformly tighten the nuts on assembly tool until the segment securing band slips over the end of the segments.

When securing band is properly seated around segments, loosen nuts and remove tool.

Add a fillet of end seal where the hose extends out of the fitting.

Clean, Inspect and Proof Test.

# Assembly Instructions

## FC132 Hose and Fittings



To determine "J" length (length of hose): from "OA" (overall length) deduct "D" dimensions of both end fittings.

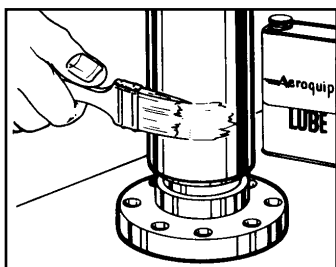

1. Cut hose squarely to length using a sharp knife or cut off saw. Hose should be bent slightly away from the cutting edge to prevent binding. A water soluble oil may be used to cool the blade. Clean hose bore.
2. Insert the nipple into the hose until the hose bottoms squarely against the nipple shoulder. Apply a light coat of lubricant to the exterior cover at both ends of the hose, covering the last 5 inches of each end.

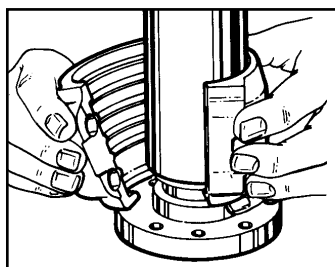

3. Place the shoulder of each segment into the nipple assembly as shown.

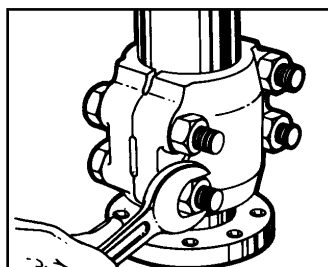

4. Insert the 4 bolts through the matching segment holes. Lubricate bolt threads with a light coat of Molykote Type GN Paste or similar molybdenum disulfide lubricant. Start the nuts, and holding the segment parallel, tighten the bolts alternately keeping gaps between segments equal, until the segment stops meet, or torque values listed below are reached, whichever occurs first.

Torque Values: -40 80 to 90 Ft. lbs., -48 120 100 RPM, to 130 Ft. lbs., -64 170 to 180 Ft. lbs. NOTE preferred speeds are 40 to 50 RPM. It is recommended to re-torque bolts after proof testing.

### INSTRUCTIONS FOR ASSEMBLY OF MONEL AND STAINLESS STEEL FITTINGS

The best assembly lubricant for these two materials is Molykote GN paste\*. This Molybdenum disulfide lubricant performs best when applied full strength, per the manufacturer's instructions on the label. Minimal heat will be generated during assembly or disassembly when the following steps are followed:

1. Apply Molykote GN paste to all threaded surfaces every time the components are assembled.
2. Assemble and disassemble in a continuous motion.
3. Avoid side loading during assembly or disassembly.
4. Speeds should not exceed

\*Trademark of Dow Corning Corporation.

# Assembly Instructions

## 2580 Hose and Fittings -80 thru -192 with Bolt Type End Fittings



To determine "J" length (cut length of hose): from "OA" (overall length) deduct "D" dimensions of both end fittings.

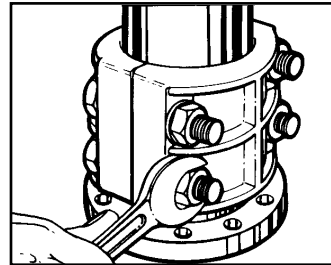
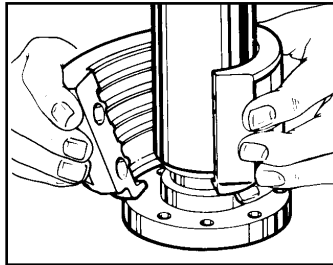
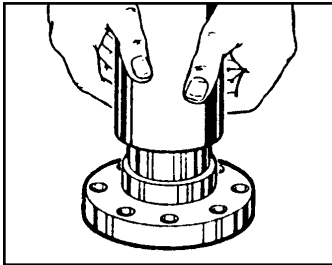

1. Cut hose squarely with a sharp cut off wheel. Hose should be bent slightly away from the cutting edge to prevent binding. A water soluble oil may be used to cool the blade. Clean hose bore.
2. When slip-over components (flanges, etc.) are used, assemble these to the nipple first. Lubricate the nipple liberally with Aero Lube. Push the hose onto the nipple until the hose bottoms squarely against the nipple shoulder.
3. Place the socket segments around the hose at the nipple area. Lubricate the bolts with Molykote GN Paste. Washers must be used on the nuts.
4. Align the segment shoulders with the nipple groove. Tighten the segments uniformly until the segment bosses make contact with the adjoining segment.

# Assembly Instructions

## For hose assemblies with steel or bronze Bolt Together Segmented Socket Fittings $\bar{D}$ For Hose 2758



To determine "J" length (length of hose): from "OA" (overall length) deduct "D" dimensions of both end fittings.

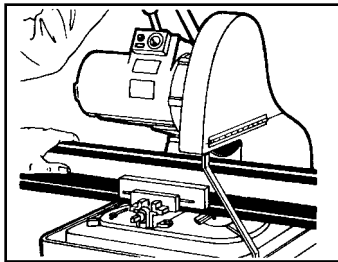

1. Cut hose squarely to desired length using a high speed abrasive wheel or steel cut off wheel. Hose may also be cut with a fine toothed hacksaw or an Aeroquip Cut-off Machine (S1104, FT1260, S112C page 153-154). Hose should be bent so that the outside of the bend contacts the wheel to prevent binding. Do not feed the hose to the cutting edge too fast as it may tend to loosen the wire reinforcement or cause unraveling. After the cutting operation is complete, clean all residue from the inside and outside of the hose.

If cutting the hose has caused the end to neck down slightly, it can be flared with a smooth tool to allow proper insertion of the nipple.

2. Apply thin coat of end sealing compound to the hose ends and to the outer cover which will be covered by the fitting socket, and allow to dry for about 1/2 hour. Do not allow end sealant to enter hose bore. Immediately before installing nipple, apply a second thin coat of end sealing compound over the first thin coat.

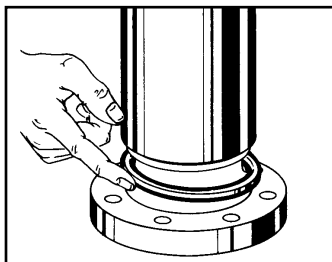

3. Place retaining ring over nipple and push hose onto nipple until it bottoms squarely on the shoulder of the nipple. In case of flanged ends, be sure the flange is in place on the nipple before putting retaining ring on and inserting into hose.

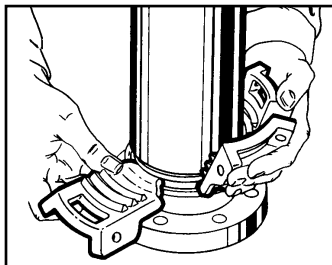

4. Hook segments into retaining ring and space them evenly around hose. In the case of the bronze segments (-80 and -96) be sure that the letter "R" is stamped on each segment. (This indicates that the parts have been radiographed).

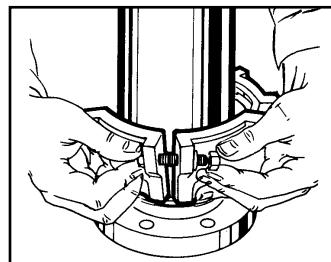

5. a. Using only K-monel bolts and nuts, and beryllium copper washers, place washers under heads of bolts. Lubricate the bolts with Molykote Type GN Paste or equivalent and insert into holes so all face the same direction. For bronze segment sockets in the -80 and -90 sizes, belled washers are used; see page 107 for part numbers. When assembling, convex surfaces of belled washers should be against bolt head and nut.

Note: New bolts and nuts should always be used for each reassembly.

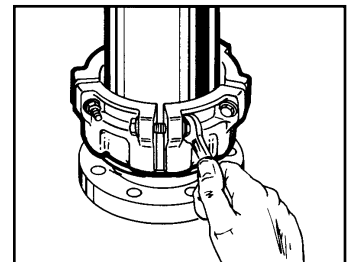

6. Recheck all spacing and then tighten nuts uniformly, working around the fitting four or five times until the sides of the adjacent segments are parallel to each other, however, the adjacent segments may be 1/8 inch wider at the bolt center line than at the ring.

# Technical Data

## Number Index

SECTION	PAGES
Master Index	3-6
ÒFHÓ Competitor Part Number Conversion Chart	7
Hose	8-23
Fittings	24-141
Adapters	142-144
Accessories Assembly Instructions And Assembly equipment	145-173
Technical Data	174-205

HOSE AND ACCESSORIES	PAGE
<b>LOW PRESSURE</b>	
2565	11
2556	11
<b>MEDIUM PRESSURE</b>	
303/302A	12
FC163	15
FC173	12
2665	13
AE372	13
FC234	14
AE369	14
2580 -4 thru -32	15
<b>HIGH PRESSURE</b>	
AE373	16
FC162	16
AE374	17
AE370	17
AE371	18
2766	18
<b>LARGE BORE</b>	
FC132	19
2580 -80 thru -192	19
150901	20
2758	20
<b>PTFE (Teflon*)</b>	
FC363	21
FC364	21
2807	22
2808	22
<b>Specials</b>	
678 (Hose Assemblies)	23

\*Teflon is a DuPont trademark



# Technical Data

## Assembly Tips

### Terms

- Skive—Strip, as to strip-off a thin layer of cover material.
- Dash Size—The hose or fitting size expressed in  $\frac{1}{16}$  of an inch. The numerator of a fraction whose denominator is 16. Example: -8 or -08 is  $\frac{8}{16}$  =  $\frac{1}{2}$ ".
- Nipple—The part of a hose fitting that goes into the hose tube.
- Socket—The part of a hose fitting that goes over the hose cover or reinforcement.
- Mandrel—A round, properly sized, steel bar used for support during assembly of the fitting or skiving the hose cover.

### Reusable fitting tips to remember for easy assembly

- Part numbers and dash sizes are indicated on fitting sockets.
- It is essential the fitting be mated with a compatible hose style with the same dash size.
- Reusable fittings that have a notch in the socket serve as a reference for the cover skiving length.
- Familiarize yourself with the assembly instructions before you start to make an assembly.
- For hoses that require skiving, be sure to skive the hose to the proper length and down to the wire reinforcement.
- Use Eaton Aeroquip 222070 hose assembly lube liberally on both the inside of hose and on the fitting nipple (Check for compatibility).
- Always cut hose square by using a sharp instrument
- For volume production of hose assemblies, use Aeroquip Assembly Equipment.

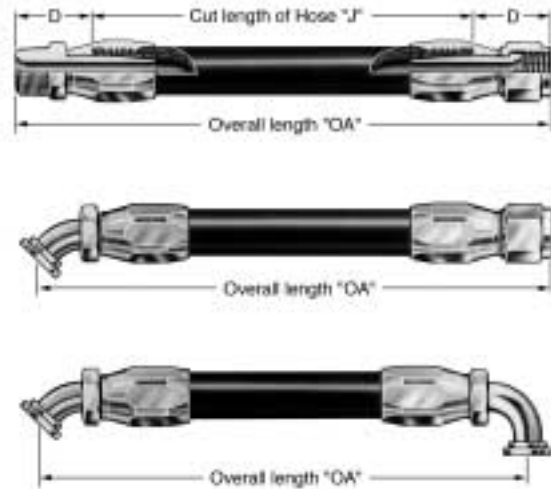

### Cutting the hose

1. To determine the "J" length (cut length of hose) from "OA" (overall length) deduct "D" dimensions of both end fittings. Consult reusable fitting information pages for "D" dimensions. For hose assemblies with SOCKETLESS® fittings, add  $\frac{1}{2}$ " to "J" length. Tip: If the old Aeroquip assembly was the right length, simply remove the hose fittings and measure the hose.
2. Cut the hose square.
3. Clean the hose bore. Blow out shavings with shop air, flush with a solvent compatible with the hose or use a low pressure air gun. The Jetcleaner™ system routes a foam projectile through the hose to thoroughly remove the debris remaining from cutting and skiving operations. Caution: Follow proper safety procedures.



### Phase angle (offset)

When making double elbow assemblies, the following steps should be followed to obtain the desired angle between elbows. Tighten both elbows to maximum allowable gap between socket and nipple hex. Start to position for relative angle between elbows. Finish assembly by adjusting both elbows. Backing off to get desired angle should be avoided.

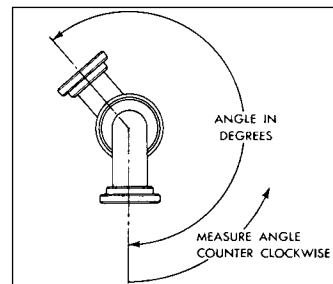

# Technical Data

## Fluid Compatibility

This chart indicates the suitability of various elastomers and metals for use with fluids to be conveyed. It is intended as a guide only and is not a guarantee. Final selection of the proper hose style, seal, or material of metal components is further dependent on many factors including pressure, fluid and ambient temperature, concentration, duration of exposure, etc.

### HOW TO USE THE CHART

1. The chart has separate sections for rating elastomers for use as hose inner tubes and as seals. Ratings for a given elastomer may not always be the same in both sections.
2. Both the elastomer and the metal must be considered when determining suitability of a combination for a hose assembly, adapter with O-Ring, swivel joint or coupling.
3. Locate the fluid to be conveyed and determine the suitability of the elastomeric and metal components according to the resistance ratings shown for each.
4. Specific hose part numbers can be found under the inner tube material groupings in the Hose Tube Identification Chart below.
5. Dimensional and operating specifications for each hose can be found on the catalog pages shown with each hose part number.
6. Information on O-Rings and seal options are shown in the respective sections of this catalog.

7. For further details on the products shown in this catalog, and their applications, contact Eaton.

### RESISTANCE RATING KEY

- E = Excellent – Fluid has little or no effect.  
 G = Good – Fluid has minor to moderate effect.  
 C = Conditional – Service conditions should be described to Eaton for determination of suitability for application.  
 U = UNSATISFACTORY

The differences between ratings "E" and "G" are relative. Both indicate satisfactory service. Where there is a choice, the materials rated "E" may be expected to give better or longer service than those rated "G".

**NOTE:** Special precautions are necessary in gaseous applications due to the potential volume of gaseous fluid in the system. Unless the cover is perforated, hose styles with rubber or thermoplastic covers are not suitable for gases above 250 psi. Hose styles with perforated covers are so noted in their construction descriptions.

### HOSETUBE IDENTIFICATION CHART

#### 1 SYNTHETIC RUBBER

302A (p. 12)	AE369 (p. 14)
303 (p. 12)	AE370 (p. 17)
2556 (p. 11)	AE371 (p. 18)
2565 (p. 11)	AE374 (p. 17)
2580 (p. 15, 19)	FC132 (p. 19)
2665 (p. 13)	FC162 (p. 16)
2758 (p. 20)	FC163 (p. 15)
2766 (p. 18)	FC173 (p. 12)
150901 (p. 20)	

#### 2 PTFE

2807 (p. 22)	FC363 (p. 21)
2808 (p. 22)	FC364 (p. 21)
678 (p. 23)	

#### 4 AQP

AE373 (p. 16)
AE372 (p. 13)
FC234 (p. 14)(Fuel)

#### 5 EPDM

### SEAL ELASTOMER DATA

SEAL ELASTOMER	APPLICATION SPECIFICATION	MAX. OPERATING TEMPERATURE RANGE
Buna-N	none	Ø40;F to +250;F (Ø40;C to +121;C)
Neoprene	none	Ø65;F to +300;F (Ø54;C to +149;C)
EPR (Ethylene Propylene Rubber)/ EPDM	none	Ø65;F to +300;F (Ø54;C to +149;C)
Viton*	MIL-R-25897	Ø15;F to +400;F (Ø29;C to +204;C)

Buna-N temperature range -65;F to +225;F. Also per MIL-R-6855.

\*Viton is a DuPont trademark.



**WARNING:** Compatibility of hose fittings with conveyed fluid is an essential factor in avoiding chemical reactions that may result in release of fluids or failure of the connection with the potential of causing severe personal injury or property damage.

# Technical Data

## Fluid Compatibility

FLUID	HOSE					SEALS						METAL				
	1 SYNTHETIC RUBBER	2 PTFE	3 THERMOPLASTIC ELASTOMER	4 AQP	5 EPDM	BUNA-N	NEOPRENE	EPR	VITON*	URETHANE	HYTREL	STEEL	BRASS	STAINLESS STEEL	ALUMINUM	MONEL
Acetaldehyde	U	E	G	U	E	U	C	C	U	U	G	G	E	E	E	E
Acetic Acid, 10%	U	E	C	G	C	U	U	E	G	U	C	U	U	C	C	C
Acetic Acid, Glacial	U	E	C	G	E	U	U	C	U	U	C	U	U	C	C	C
Acetone	U	E	G	G	E	U	U	G	U	U	G	E	E	E	E	E
Acetophenone	U	E	Ø	C	E	U	U	E	U	U	Ø	E	E	E	C	E
Acetyl Acetone	U	E	G	G	E	U	U	G	U	U	G	U	C	C	C	C
Acetyl Chloride	U	E	U	G	U	U	U	U	E	U	U	C	C	C	C	U
Acetylene	U	E	G	G	E	U	U	G	E	G	C	E	E	E	E	E
Air, Hot (Up to +160jF)	E	E	E	E	E	E	E	E	E	E	E	E	E	E	E	E
Air, Hot (161jF Ø 200jF)	C	E	G	E	C	C	G	G	E	E	G	G	E	E	E	E
Air, Hot (201jF Ø 300jF)	U	E	U	C	U	U	U	G	E	U	U	U	E	E	E	E
Air Wet	E	E	C	E	E	E	E	E	E	G	C	U	G	E	E	E
Aluminum Chloride	E	E	E	E	E	E	E	E	E	G	E	U	U	U	U	U
Aluminum Fluoride	E	E	E	E	E	E	E	E	E	G	E	U	U	U	U	E
Aluminum Nitrate	E	E	E	E	E	E	E	E	E	G	E	U	U	C	C	C
Aluminum Sulfate	E	E	G	E	E	E	E	E	E	Ø	G	U	C	E	C	C
Alums	E	E	E	E	E	E	E	E	E	E	E	U	C	E	C	C
Ammonia, Cold	U	G	U	U	E	E	E	E	U	Ø	Ø	E	U	E	E	E
Ammonia, Hot	U	G	U	U	E	U	G	G	U	Ø	Ø	E	U	E	E	E
Ammonia, Anhydrous	U	G	U	U	U	E	E	E	U	Ø	Ø	E	U	E	E	E
Ammonia, Aqueous	U	G	U	U	E	E	E	E	U	Ø	Ø	E	U	E	E	E
Ammonium Carbonate	U	E	C	G	E	U	E	E	U	Ø	C	C	U	C	C	C
Ammonium Chloride	E	E	C	G	E	E	E	E	U	Ø	Ø	U	U	C	U	C
Ammonium Hydroxide	C	E	U	C	E	C	C	E	C	U	G	U	C	C	U	U
Ammonium Nitrate	G	E	C	G	E	E	G	E	U	G	C	G	U	G	G	U
Ammonium Phosphate	E	E	C	E	E	E	E	E	Ø	G	C	U	C	G	U	C
Ammonium Sulfate/Sulfide	E	E	C	E	E	E	E	E	U	G	C	U	U	G	U	C
Amyl Acetate	U	E	U	U	E	U	U	G	U	U	U	E	E	E	E	E
Amyl Alcohol	G	E	E	E	E	G	C	E	G	C	E	G	G	E	U	G
Aniline, Aniline Oil	U	E	U	C	E	U	U	G	U	U	U	E	U	E	G	G
Aniline Dyes	U	E	U	C	E	U	G	G	G	U	U	U	C	G	C	G
Arsenic Acid	E	E	G	C	E	E	E	E	E	C	G	U	U	G	U	C
Asphalt	C	E	G	E	E	G	C	U	E	G	C	E	G	E	C	E
ASTM #1	E	E	E	E	U	E	E	C	E	E	E	E	E	E	E	E
ASTM #2	G	E	E	E	U	E	G	U	E	G	E	E	E	E	E	E
ASTM #3	G	E	E	E	U	E	G	U	E	G	E	E	E	E	E	E
Automatic Trans. Fluid	G	E	G	E	U	E	G	U	E	C	G	E	E	E	E	E
Barium Chloride	E	E	C	E	E	E	E	E	E	G	C	U	G	G	G	G
Barium Hydroxide	E	E	G	E	E	E	E	E	E	E	G	U	G	U	G	U
Barium Sulfide	E	E	C	E	E	E	E	E	E	G	C	C	U	G	U	U
Benzene, Benzol	U	E	C	C	U	U	U	U	E	U	C	G	E	E	G	E
Benzin	G	E	C	C	U	E	U	U	E	U	C	E	E	E	E	E
Benzoic Acid	U	E	C	C	U	U	U	U	E	C	C	U	G	G	G	G
Benzyl Alcohol	U	E	C	G	E	U	G	G	E	C	C	E	G	E	G	G
Black Sulfate Liquor	G	E	C	C	E	C	C	C	E	U	C	E	C	E	U	U
Blast Furnace Gas	U	U	C	G	U	U	U	U	E	U	C	E	C	E	U	U
Borax	G	E	G	G	E	G	G	E	E	G	C	E	E	E	G	Ø
Boric Acid	G	E	G	E	E	G	G	G	E	G	G	U	G	C	C	C

\*Viton is a DuPont trademark.

This chart is intended for reference use only. The information in this chart pertains strictly to material compatibility and is not intended to be used as an application guide. For information on specific applications not included in this catalog, please contact Eaton.

# Technical Data

## Fluid Compatibility

FLUID	HOSE					SEALS						METAL				
	1	2	3	4	5	BUNA-N	NEOPRENE	EPR	VITON*	URETHANE	HYTREL	STEEL	BRASS	STAINLESS STEEL	ALUMINUM	MONEL
Brine	G	E	C	E	E	E	G	E	E	G	C	U	G	G	U	E
Bromine	U	E	U	U	U	U	U	U	E	U	U	U	C	U	C	C
Butane	LPG Approved Hose Only					E	E	U	E	DD	DD	E	E	E	E	E
Butyl Acetate	U	E	C	C	U	U	U	G	U	U	C	E	E	E	E	E
Butyl Alcohol	E	E	G	E	E	E	E	G	E	GG	GG	G	G	G	G	G
Butyl Cellosolve	U	E	C	G	E	U	U	G	U	U	C	E	E	E	E	E
Butylene	U	E	D	C	U	C	U	U	E	UD	UD	E	E	E	E	E
Butyl Stearate	U	E	D	G	U	G	U	U	E	D	D	G	G	G	G	G
Butyraldehyde	U	E	D	C	E	U	U	G	U	UD	UD	E	E	E	E	G
Calcium Acetate	G	E	C	E	E	G	G	E	U	U	C	G	G	G	C	G
Calcium Bisulfate	E	E	G	G	U	E	E	U	E	G	G	U	C	C	U	U
Calcium Chloride	E	E	E	E	E	E	E	E	E	E	E	G	G	G	C	G
Calcium Hydroxide	E	E	C	E	E	E	E	E	E	U	C	G	G	G	U	G
Calcium Hypochlorite	U	E	C	E	E	U	U	E	E	U	C	U	G	C	U	U
Calcium Nitrate	E	E	E	E	E	E	E	E	E	E	E	G	G	G	G	G
Cane Sugar Liquors	E	E	E	E	E	E	E	E	E	U	E	E	E	G	E	E
Carbitol	G	E	G	E	E	G	G	G	G	U	C	E	E	E	E	E
Carbolic Acid	U	E	U	E	E	U	U	G	E	U	U	U	E	E	D	D
Carbonic Acid	G	E	C	E	E	G	E	E	E	C	C	U	C	E	G	E
Carbon Dioxide	G	E	E	E	E	G	G	E	E	GE	GE	E	E	E	E	E
Carbon Disulfide	U	E	C	C	U	U	U	U	E	C	C	G	G	G	E	G
Carbon Monoxide	G	E	E	E	E	G	G	E	E	GE	GE	E	E	E	E	E
Carbon Tetrachloride	U	E	U	C	U	U	U	U	E	UU	UU	U	G	G	U	E
Castor Oil	E	E	G	E	E	E	E	G	E	G	G	E	E	E	E	E
Cellosolve Acetate	U	E	U	C	E	U	U	G	U	UU	UU	U	U	E	G	E
China Wood Oil (Tung Oil)	G	E	C	G	U	G	G	U	E	U	U	C	E	G	E	E
Chlorine	U	U	U	U	U	U	U	U	G	U	U	C	C	C	C	C
Chloroacetic Acid	U	E	U	C	E	U	U	G	U	UU	UU	U	U	U	U	G
Chloroacetone	U	E	U	U	E	U	U	E	U	UU	UU	G	G	G	U	G
Chlorobenzene	U	E	U	C	U	U	U	U	G	UU	UU	G	G	G	G	G
Chloroform	U	E	U	C	U	U	U	U	E	UU	UU	G	G	G	G	G
O-Chlorophenol	U	E	U	C	U	U	U	U	E	UU	UU	G	G	G	U	G
Chlosulfonic Acid	U	E	U	U	U	U	U	U	U	UU	UU	G	U	G	G	C
Chrome Plating Solution	U	E	D	U	E	U	U	G	E	U	D	C	U	U	U	U
Chromic Acid	U	E	D	C	E	U	U	C	E	U	D	C	U	U	U	U
Citric Acid	E	E	C	E	E	E	E	E	E	EC	EC	C	C	C	C	C
Coke Oven Gas	U	E	D	G	U	U	U	U	E	U	D	E	C	E	U	U
Copper Chloride	E	E	E	E	E	E	E	E	E	G	E	U	U	U	U	U
Copper Cyanide	E	E	D	E	E	E	E	E	E	E	D	E	U	G	U	G
Copper Sulfate	E	E	G	E	E	E	E	E	E	G	G	U	C	G	U	G
Cotton Seed Oil	G	E	E	E	U	E	G	C	E	EE	EE	E	E	E	E	E
Creosote (Coal Tar)	C	E	U	G	U	G	C	U	E	U	U	E	C	E	E	E
Crude Oil	G	E	C	E	U	E	G	U	E	G	C	G	U	G	U	U
Cyclohexanol	G	E	C	E	U	E	G	U	E	C	C	E	E	E	C	E
Cyclohexanone	U	E	G	C	E	U	U	G	U	G	G	E	E	E	C	E
Detergent/Water Solution	E	E	C	E	E	E	E	E	E	C	C	G	E	E	E	E
Diacetone Alcohol (Acetol)	U	E	C	E	E	U	U	E	U	C	C	E	E	E	E	E
Dibenzyl Ether	U	E	D	C	E	U	U	G	U	D	D	G	G	G	G	G

\*Viton is a DuPont trademark.

This chart is intended for reference use only. The information in this chart pertains strictly to material compatibility and is not to be used as an application guide. For information on specific applications not included in this catalog, please contact Eaton.

# Technical Data

## Fluid Compatibility

FLUID	HOSE					SEALS						METAL				
	1 SYNTHETIC RUBBER	2 PTFE	3 THERMOPLASTIC ELASTOMER	4 AQP	5 EPDM	BUNA-N	NEOPRENE	EPR	VITON*	URETHANE	HYTREL	STEEL	BRASS	STAINLESS STEEL	ALUMINUM	MONEL
Diesel Oil	C	E	C	G	U	E	C	U	E	C	C	E	E	E	E	E
Diethylamine	G	E	Ø	C	E	G	G	G	U	Ø	Ø	E	U	E	Ø	E
Diocetyl Phthalate (DOP)	U	E	C	C	E	U	U	G	G	C	C	E	E	E	E	E
Dowtherm A&E	U	E	Ø	C	U	U	U	U	E	Ø	Ø	G	U	E	E	E
Dowtherm 209	C	E	Ø	E	E	C	G	E	U	Ø	Ø	Ø	Ø	Ø	Ø	Ø
Ester Blend	C	E	C	E	E	E	U	U	E	UE	E	E	E	E	E	E
Ethyl Alcohol (Ethanol)	E	E	C	E	E	E	E	E	E	C	C	E	E	E	E	G
Ethyl Acetate	U	E	C	C	E	U	U	G	U	C	C	E	E	E	E	E
Ethyl Benzene	U	E	Ø	C	E	U	U	U	E	U	Ø	E	G	G	G	G
Ethyl Cellulose	G	E	C	C	E	G	G	G	U	C	C	E	G	G	G	G
Ethyl Chloride	U	E	U	C	E	U	U	U	E	U	U	E	E	E	G	G
Ethylene Dichloride	U	E	U	C	U	U	U	U	G	U	U	G	C	G	G	G
Ethylene Glycol	E	E	C	E	E	E	E	E	E	C	C	U	G	E	E	E
Ferric Chloride	G	E	Ø	E	E	E	G	E	E	Ø	Ø	U	U	U	U	U
Ferric Nitrate	E	E	C	E	E	E	E	E	E	C	C	U	U	G	U	U
Ferric Sulfate	G	E	C	G	E	G	G	G	E	C	C	U	U	E	U	U
Formaldehyde	C	E	C	G	E	C	C	G	G	C	C	E	E	E	G	G
Formic Acid	C	E	U	E	E	C	G	E	U	U	U	U	C	C	C	C
Fuel Oil	G	E	E	E	U	E	G	U	E	G	G	E	E	E	E	E
Furfural	C	E	Ø	E	E	C	C	G	U	U	E	G	G	G	G	G
Gallic Acid	G	E	Ø	E	E	G	G	G	E	U	Ø	U	Ø	G	C	G
Gasoline	C	E	E	E	U	E	C	U	E	EE	E	E	E	E	E	E
Gasohol	U	E	G	E	U	G	G	U	E	EE	E	E	E	G	E	E
Glycerine/Glycerol	E	E	E	E	E	E	E	E	E	G	E	E	G	E	E	E
Green Sulfate Liquor	G	E	Ø	E	E	G	G	E	E	Ø	Ø	U	U	E	U	U
Helium	C	G	C	C	E	E	E	E	E	EE	E	E	E	E	E	E
Heptane	G	E	E	E	U	E	G	U	E	G	C	E	E	E	E	E
Hexaldehyde	C	E	Ø	C	E	U	G	G	U	U	Ø	G	G	E	E	E
Hexane	G	E	E	E	U	E	G	U	E	G	C	E	E	E	E	E
Hydraulic Oils																
Ester Blend	C	E	C	E	E	E	U	U	E	UE	E	E	E	E	E	E
Phos. Ester/Petroleum Blend	U	E	C	E	Ø	U	U	U	C	U	G	E	E	E	E	E
Silicone Oils	E	E	E	E	E	E	E	E	E	EE	E	E	E	E	E	E
Straight Petroleum Base	E	E	E	E	U	E	G	U	E	EE	E	E	E	E	E	E
Straight Phosphate Ester	U	E	C	C	E	U	U	G	C	U	G	E	E	E	E	E
Water Glycol	E	E	C	E	E	E	E	E	E	C	C	E	E	E	G	G
Water Petroleum Emulsion	G	E	C	E	U	E	G	U	E	C	C	C	E	E	G	G
Hydrobromic Acid	U	E	U	C	E	U	U	E	E	U	U	E	U	E	E	U
Hydrochloric Acid	U	E	U	C	C	U	U	G	E	UU	U	U	U	U	U	U
Hydrocyanic Acid	C	E	Ø	C	E	C	C	E	E	Ø	E	E	G	E	G	G
Hydrofluoric Acid	U	E	U	C	C	U	U	C	U	UU	U	U	U	U	C	C
Hydrofluorosilic Acid	G	E	Ø	G	E	G	G	E	E	Ø	Ø	U	U	U	U	U
Hydrogen	C	C	C	C	E	E	E	E	E	EE	E	E	E	E	E	E
Hydrogen Peroxide	G	E	G	E	C	G	G	G	E	GG	U	U	G	E	U	U
Hydrogen Sulfide, Dry	U	C	C	G	E	U	G	E	U	Ø	G	E	G	G	G	G
Isocyanate	U	E	U	C	U	U	U	G	E	U	U	G	Ø	G	Ø	Ø
Iso Octane	G	E	E	E	U	E	G	U	E	GE	E	E	E	E	E	E
Isopropyl Acetate	U	E	C	U	E	U	U	G	U	U	C	E	Ø	E	E	E

\*Viton is a DuPont trademark.

This chart is intended for reference use only. The information in this chart pertains strictly to material compatibility and is not to be used as an application guide. For information on specific applications not included in this catalog, please contact Eaton.

# Technical Data

## Fluid Compatibility

FLUID	HOSE					SEALS						METAL				
	1	2	3	4	5	BUNA-N	NEOPRENE	EPR	VITON*	URETHANE	HYTREL	STEEL	BRASS	STAINLESS STEEL	ALUMINUM	MONEL
Isopropyl Alcohol	G	E	C	E	E	G	G	E	E	U	C	E	E	E	G	E
Isopropyl Ether	C	E	D	C	U	G	U	U	U	C	D	G	G	G	D	D
JP-4, JP-5	C	E	G	G	U	E	U	U	E	U	G	E	E	E	E	E
Kerosene	C	E	G	G	U	E	U	U	E	U	G	E	E	E	E	E
Lacquer/Lacquer Solvents	U	E	C	C	U	U	U	U	U	U	G	U	E	E	E	E
Lime Sulfur	C	E	C	E	E	U	E	E	E	C	C	G	U	G	D	U
Linseed Oil	G	E	G	E	U	E	G	U	E	G	G	E	E	E	E	E
LPG	C	D	D	D	U	E	G	U	E	D	D	E	E	E	E	E
Lubricating Oils	See Hydraulic Oils															
Magnesium Chloride	E	E	C	E	E	E	E	E	E	C	C	E	C	C	G	G
Magnesium Hydroxide	G	E	C	E	E	G	G	E	E	C	C	E	G	E	G	E
Magnesium Sulfate	E	E	C	E	E	E	E	E	E	C	C	E	E	E	E	E
Maleic Acid	U	E	C	G	E	U	U	U	E	C	C	E	G	G	G	G
Maleic Anhydride	U	E	C	G	U	U	U	U	E	C	C	G	U	E	G	G
Malic Acid	G	E	D	G	U	G	G	U	G	D	E	U	D	E	G	E
Mercuric Chloride	E	E	E	E	E	E	E	E	E	E	E	U	U	U	U	U
Mercury	E	E	E	E	E	E	E	E	E	E	E	U	E	U	U	G
Methanol	G	E	C	G	E	G	G	E	U	C	C	G	G	E	C	E
Methyl Bromide	U	E	U	C	U	G	U	U	E	U	U	E	E	G	U	E
Methyl Chloride	U	E	U	C	U	U	U	U	E	U	U	E	E	E	U	G
Methyl Butyl Ketone	U	E	C	C	E	U	U	E	U	C	C	E	E	E	D	E
Methyl Ethyl Ketone	U	E	C	C	E	U	U	E	U	UG	G	G	G	G	G	G
Methylene Chloride	U	E	U	C	G	U	U	U	G	UU	G	G	G	G	G	G
Methyl Isobutyl Ketone	U	E	U	C	G	U	U	U	U	UU	G	G	G	G	G	G
Methyl Isopropyl Ketone	U	E	U	C	G	U	U	U	U	UU	G	G	G	G	G	G
Methyl Salicylate	U	E	D	U	C	U	U	C	U	D	D	E	G	G	E	G
MIL-L-2104	E	E	E	E	U	E	G	U	E	EE	E	E	E	D	E	E
MIL-H-5606	E	E	E	E	U	E	G	U	E	EE	E	E	E	E	E	E
MIL-H-6083	E	E	E	E	U	E	E	U	E	EE	E	E	E	D	E	E
MIL-L-7808	C	E	G	G	U	G	U	U	E	GG	G	G	E	D	D	D
MIL-L-23699	C	E	D	G	U	G	U	U	E	DD	E	E	E	E	E	E
MIL-H-46170	G	E	D	G	C	E	G	U	E	DD	E	E	E	D	E	E
MIL-H-83282	C	E	D	G	U	E	U	U	E	DD	E	E	E	D	E	E
Mineral Oils	C	E	G	E	U	E	G	U	E	G	G	E	E	E	E	E
Naphtha	U	E	G	C	U	C	U	U	E	C	G	D	D	D	D	D
Naphthalene	U	E	G	C	U	U	U	U	E	C	G	E	G	E	G	G
Naphthenic Acid	U	E	D	C	U	C	U	U	E	D	D	D	G	E	G	G
Natural Gas	C	U	U	U	U	E	E	U	E	D	D	G	G	G	G	G
Nickel Acetate	U	E	U	G	E	C	C	E	G	U	U	G	C	E	G	E
Nickel Chloride	G	E	U	E	E	E	G	E	E	UU	U	U	G	U	G	G
Nickel Sulfate	E	E	U	E	E	E	E	E	E	UU	U	G	G	U	G	G
Nitric Acid, to 10%	U	E	C	C	U	U	U	U	E	U	C	U	U	E	U	U
Nitric Acid, over 10%	U	E	U	U	U	U	U	U	G	UU	U	U	E	C	U	U
Nitrobenzene	U	E	U	C	E	U	U	U	G	U	U	E	G	E	E	E
Nitrogen	E	E	E	E	E	E	E	E	E	EE	E	E	E	E	E	E
Octyl Alcohol	E	E	E	E	E	E	E	E	E	EE	E	E	E	E	E	E
Oleic Acid	U	E	G	C	U	U	U	C	G	G	E	C	E	G	C	G
Oleum (Fuming Sulfuric Acid)	U	E	U	U	U	U	U	U	E	U	G	U	G	U	U	U

\*Viton is a DuPont trademark.

This chart is intended for reference use only. The information in this chart pertains strictly to material compatibility and is not intended to be used as an application guide. For information on specific applications not included in this catalog, please contact Eaton.

# Technical Data

## Fluid Compatibility

FLUID	HOSE					SEALS						METAL				
	1 SYNTHETIC RUBBER	2 PTFE	3 THERMOPLASTIC ELASTOMER	4 AQP	5 EPDM	BUNA-N	NEOPRENE	EPR	VITON*	URETHANE	HYTREL	STEEL	BRASS	STAINLESS STEEL	ALUMINUM	MONEL
Oleum (Mineral Spirits)	E	E	G	E	U	E	G	U	E	G	G	E	E	E	E	E
Ortho-Dichlorobenzene	U	E	D	U	U	U	U	U	E	D	D	G	G	G	G	G
Oxalic Acid	G	E	C	G	E	G	G	E	E	C	C	U	C	C	C	C
Oxygen	U	U	U	U	U	D	D	D	D	D	D	G	G	G	G	G
Palmitic Acid	G	E	E	D	E	E	G	G	E	D	E	G	D	E	E	G
Para-Dichlorobenzene	U	E	D	U	U	U	U	U	E	D	D	G	G	G	G	G
Pentane	E	E	G	E	U	E	E	U	E	U	G	G	G	G	E	E
Perchloric Acid	C	E	U	G	E	E	G	G	E	U	U	U	U	U	U	U
Perchloroethylene	U	E	U	U	U	U	U	U	E	U	U	C	G	G	G	G
Phenol (Carbolic Acid)	U	E	U	E	U	U	U	G	E	U	U	U	E	E	E	E
Phos. Ester/Petroleum Blend	U	E	C	E	D	U	U	U	C	U	G	E	E	E	E	E
Phosphoric Acid	U	E	U	C	E	U	U	G	E	U	U	U	E	U	C	C
Phosphorous Trichloride	U	E	U	C	E	U	U	E	E	U	U	C	U	C	E	E
Potassium Acetate	G	E	D	E	E	G	G	E	U	D	D	C	G	C	U	C
Potassium Chloride	E	E	E	E	E	E	E	E	E	E	E	E	E	C	E	U
Potassium Cyanide	E	E	E	E	E	E	E	E	E	E	E	C	U	G	U	C
Potassium Dichromate	E	E	E	E	E	E	E	E	E	E	E	C	C	C	C	C
Potassium Hydroxide, to 10%	G	E	C	E	E	G	G	E	G	C	C	G	G	G	G	U
Potassium Hydroxide, over 10%	C	E	U	C	E	C	C	E	U	U	U	G	G	G	G	U
Potassium Nitrate	E	E	E	E	E	E	E	E	E	E	E	G	G	E	E	G
Potassium Sulfate	E	E	E	E	E	E	E	E	E	E	E	D	D	D	D	D
Propane	C	D	D	D	U	C	D	D	D	D	D	E	E	E	E	E
Propyl Acetate	U	E	D	G	E	U	U	G	U	D	D	E	D	E	E	E
Propyl Alcohol	E	E	U	E	E	E	E	E	E	U	U	E	E	E	E	E
Propylene	U	E	D	U	U	U	U	U	E	D	D	E	E	E	E	E
Refrigerant R-12	C	D	G	U	U	G	E	C	E	E	E	E	E	E	E	E
Refrigerant R-13	C	D	G	U	U	G	E	C	E	E	E	E	E	E	E	E
Refrigerant R-22	U	C	U	U	U	U	E	C	U	U	U	E	E	E	E	E
Refrigerant R-134a	U	C	U	U	U	E	C	U	U	U	E	E	E	E	E	E
Sewage	E	E	E	E	E	E	E	E	E	U	E	G	G	G	G	G
Silicone Oils	E	E	E	E	E	E	E	E	E	E	E	E	E	E	E	E
Soap (Water Solutions)	E	E	C	E	E	E	E	E	E	C	C	E	E	E	E	U
Sodium Acetate	G	E	D	E	E	G	G	E	U	D	D	E	E	G	E	E
Sodium Bicarbonate	E	E	E	E	E	E	E	E	E	E	E	G	G	E	G	E
Sodium Borate	E	E	E	E	E	E	E	E	E	E	E	E	E	E	G	E
Sodium Carbonate	E	E	E	E	E	E	E	E	E	E	E	E	G	E	U	U
Sodium Chloride	E	E	E	E	E	E	E	E	E	E	E	U	C	C	C	C
Sodium Cyanide	E	E	E	E	E	E	E	E	E	E	E	E	D	C	U	U
Sodium Hydroxide, to 10%	C	E	G	C	E	U	G	E	E	G	G	C	G	C	U	U
Sodium Hydroxide, over 10%	U	E	C	C	E	U	U	G	E	C	C	C	C	C	U	U
Sodium Hypochlorite	C	E	C	G	C	C	C	E	C	C	C	U	U	U	U	U
Sodium Metaphosphate	E	E	E	E	E	E	E	E	E	E	E	E	G	G	U	U
Sodium Nitrate	G	E	E	E	E	G	G	E	D	E	E	E	C	E	E	E
Sodium Perborate	G	E	D	E	E	G	G	E	E	D	D	C	U	C	U	U
Sodium Peroxide	G	E	D	E	E	G	G	E	E	U	D	U	U	C	C	C
Sodium Phosphates	E	E	E	E	E	E	E	E	E	E	E	U	E	G	U	U
Sodium Silicate	E	E	E	E	E	E	E	E	E	E	E	E	E	E	E	E
Sodium Sulfate	E	E	E	E	E	E	E	E	E	E	E	C	G	G	G	G

\*Viton is a DuPont trademark.

This chart is intended for reference use only. The information in this chart pertains strictly to material compatibility and is not intended to be used as an application guide. For information on specific applications not included in this catalog, please contact Eaton.

# Technical Data

## Fluid Compatibility

FLUID	HOSE					SEALS					METAL					
	1	2	3	4	5	BUNA-N	NEOPRENE	EPR	VITON*	URETHANE	HYTREL	STEEL	BRASS	STAINLESS STEEL	ALUMINUM	MONEL
Sodium Sulfide	E	E	E	E	E	E	E	E	E	E	E	C	U	C	U	G
Sodium Thiosulfate	G	E	E	E	E	G	E	E	E	E	E	U	U	C	G	E
Soy Bean Oil	G	E	G	E	U	E	G	U	E	G	G	E	E	E	E	E
Stannic Chloride	E	E	C	E	E	E	G	E	E	C	C	U	U	U	U	U
Steam (up to 388°F)	U	E	U	U	C	U	U	C	C	U	U	E	E	E	G	
Stearic Acid	G	E	G	G	E	G	G	G	E	G	G	C	C	E	C	E
Stoddard Solvent	G	E	U	E	U	E	G	U	E	U	U	E	E	E	E	E
Straight Petroleum Base	E	E	E	E	U	E	G	U	E	EE	E	E	E	E	E	E
Straight Phosphate Ester	U	E	C	C	E	U	U	G	C	U	G	E	E	E	E	E
Styrene	U	E	U	C	U	U	U	U	G	U	U	E	E	E	E	E
Sulfur	C	E	G	G	E	U	E	E	E	G	G	E	U	G	E	E
Sulfur Chloride	U	E	Ø	C	U	U	U	U	E	Ø	Ø	G	Ø	G	G	U
Sulfur Dioxide	U	E	U	C	E	U	U	G	E	U	U	E	G	G	E	G
Sulfur Trioxide	U	E	U	C	E	U	U	G	E	U	U	G	C	G	G	G
Sulfuric Acid, to 10%	U	E	U	U	E	U	G	U	E	C	C	U	G	C	Ø	E
Sulfuric Acid, over 10%	U	E	U	U	U	U	U	U	G	U	U	C	C	C	U	C
Sulfurous Acid	C	E	U	G	E	C	C	U	U	U	U	U	C	C	C	U
Tannic Acid	E	E	G	E	E	E	E	E	E	G	G	E	E	E	C	E
Tar (Bituminous)	C	E	G	C	U	G	U	U	E	G	G	E	G	E	E	E
Tartaric Acid	G	E	G	E	E	E	G	G	E	G	G	U	C	C	E	E
Tertiary Butyl Alcohol	G	E	G	G	E	G	G	G	E	GG	G	G	G	G	G	G
Titanium Tetrachloride	U	E	Ø	U	U	C	U	U	E	Ø	Ø	E	U	G	U	G
Toluene (Toluol)	U	E	U	U	U	U	U	U	E	U	U	E	E	E	E	E
Trichlorethylene	U	E	U	U	E	U	U	U	E	U	U	E	G	E	E	E
Tricresyl Phosphate	U	E	U	G	E	U	U	E	G	U	U	E	Ø	C	Ø	G
Trianthanolamine	C	E	U	E	E	E	U	E	U	U	U	E	U	E	E	E
Tung Oil	G	E	C	G	U	G	G	U	E	U	G	E	G	E	E	E
Turpentine	C	E	G	E	U	G	U	U	E	GG	G	G	G	G	G	G
Varnish	C	E	G	Ø	U	G	U	U	E	G	G	E	G	E	E	E
Vinyl Chloride	U	E	U	U	U	U	U	U	E	U	U	E	U	C	E	E
Water (to +150°F)	E	E	E	E	E	E	E	E	E	E	E	C	G	E	G	E
Water (+151°F to +200°F)	G	E	U	G	E	E	E	E	E	U	U	C	G	E	G	E
Water (+201°F to +350°F)	U	E	U	U	E	U	U	U	G	U	U	C	G	E	G	E
Water Glycol	E	E	C	E	E	E	E	E	E	C	C	E	E	E	G	E
Water Petroleum Emulsion	G	E	C	E	U	E	G	U	E	C	C	C	E	E	G	E
Xylene	U	E	E	U	U	U	U	U	E	U	C	E	E	E	E	E
Zinc Chloride	E	E	E	E	E	E	E	E	E	E	E	E	U	U	C	G
Zinc Sulfate	E	E	Ø	E	E	E	E	E	E	Ø	Ø	U	C	G	C	G

\*Viton is a DuPont trademark.

This chart is intended for reference use only. The information in this chart pertains strictly to material compatibility and is not intended to be used as an application guide. For information on specific applications not included in this catalog, please contact Eaton.

# Technical Data

## Fluid Compatibility

### Hydraulic fluids & lubricating oils

The following is a representative list of fluids and manufacturers. The fluids are grouped under generic "family" heads and arranged alphabetically. For each generic "family" listing, we have included maximum fluid temperature recommendations for the five hose classifications on **page 176** (1 through 5). Two maximum fluid temperature ratings are listed under designations of "H" and "LP".

The "H" designation is for hydraulic service up to the maximum rated operating pressure of any particular hose in the classification. The "LP" designation is for low-pressure service such as lubricating oil systems or low-pressure hydraulic return lines.

The letter "U" in the box indicates unsatisfactory resistance to the fluid type.

Fluid temperature ratings are predicated on maximum allowable ambient temperatures as follows:

### Classifications 1 and 3 (Synthetic Rubber and Thermoplastic Elastomer)

"H" fluid temperature ratings:  
+140°F ambient

"LP" fluid temperature ratings:  
+180°F ambient

### Classification 2 (PTFE)

"H" fluid temperature ratings:  
+400°F ambient

"LP" fluid temperature ratings:  
+400°F ambient

### Classification 4 (AQP)

"H" fluid temperature ratings:  
+160°F ambient

"LP" fluid temperature ratings:  
+250°F ambient

(If "H" fluid temperature is +225°F or less, allowable ambient temperature may be increased to +200°F)

Ambient temperatures in excess of those recommended, in conjunction with maximum fluid temperatures, can materially shorten the service life of the hose.

CAUTION: The fluid manufacturer's recom-

# Technical Data

## Fluid Compatibility

STRAIGHT PETROLEUM-BASE Maximum fluid temperature recommendation**	HOSE CLASSIFICATIONS (SEE PAGE 176)				Fluid Name	Delvac Oils Delvac SHC Delvac Special 10W-30 Donax T Oils DTE Oils Duro Duro AW EP Hydraulic Oils EP Industrial Oils EP Machine Oils Energol HL68 Energol HLP C68 Etna Oils Exxon ATF Factovis 52 – Conventional R & O Hydraulic Fluid Gulf Harmony AW Gulf Security AW Glide Hulburt 27 Series Hydraulic Series Hydraulic Oils Hydroil Series Industron 53 – Anti Wear Hydraulic Fluid Lubrite Motor 20W-40 Mobil AFT 210 Mobil AFT 220 Mobilfluid 62 Mobilfluid 423 Mobil Hydraulic Oils Mobiloil Special Mobiloil Super 10W-40 NUTO Oils OC Turbine Oils Peaco Oils Pennbell Oils Power-Tran Fluid Quadroil Series Rando Oils	Rando Oils HD Redind Oils Regal Oils R & O Rimula Oils Rotella Oils Rotella T Oils RPM Delo 200 Motor Oils RPM Delo 300 Motor Oils RPM Delo Special Motor Oils Rubilene Shell Brand Special Motor Oils Sun R & O Oils Suntac HP Oils Suntac WR Oils Sunvis 700 Oils Sunvis 800 Oils Sunvis 900 Oils Super Hydraulic Oils Supreme Motor Oils Tellus Oils Teresstic Oils Torque Fluids Torque Fluid 47 Torque Fluid 56 Tractor Hydraulic Fluid Union ATF Dexron Union ATF Type F Union C-2 Fluid Union C-P Oil Union Custom Motor Oil Union Gas Engine Oil Union Guardol Motor Oil Union Heavy Duty Motor Oil Union Hydraulic Oil AW Union Hydraulic Tractor Fluid Union Premium Motor Oil Union S-1 Motor Oil Union Special Motor Oil Union Super Motor Oil	Union Torque Correction Fluid Union Turbine Oil Union Turbine Oil XD Union Unax Union Unax AW Union Unax R & O Union Unax RX Union Unitec Motor Oil Univis J13 Univis J26 Univis P32 Vactra Oils Vitrea Oils Way Lubricants XD-3 Motor Oils
	1	2	3	4				
	H +200°F	+400°F	+200°F	300°F				
LP +250°F	+450°F	+200°F	300°F					

This chart is intended for reference use only. The information in this chart pertains strictly to material compatibility and is not intended to be used as an application guide. For information on specific applications not included in this catalog, please contact Eaton.

# Technical Data

## Fluid Compatibility

### WATER AND PETROLEUM OIL EMULSION (FR)

Maximum fluid temperature recommendation\*\*

HOSE CLASSIFICATIONS (SEE PAGE 176)

	1	2	3	4
H	+200°F	+250°F	+150°F	200°F
LP	+200°F	+250°F	+150°F	200°F

#### Fluid Name

Aqualube  
Astrol #587  
Chevron FR Fluid D  
Chrysler L-705  
Citgo Pacemaker Invert FR Fluid  
Conoco FR Hydraulic Fluid  
Dasco IFR  
Duro FR-HD  
Fire Resistant Hydrafluid  
Fire Resistant Hydraulic Fluid B  
FR 3110 Hydraulic Fluid (invert)  
Fyre-Safe W/O  
Gulf R & D FR Fluid  
Houghto-Safe 5046  
Houghto-Safe 5046W  
Hulsafe 500  
Hy-Chock Oil  
Hydrasol A  
Ironsides #814-A  
Irus Fluid 905  
Kutwell 40

Masol Fire Resistant Fluid  
Meltran FR 900

Mine Guard  
Mobilmet S122  
Penn Drake Hydraqua Fluid  
Permamul FR

Puro FR Fluid  
Pyrogard C  
Pyrogard D

Quintolubric 957 Series  
Quintolubric 958 Series  
Regent Hydrolube #670  
SAFOIL Hydraulic Fluid Anti-Wear  
Sinclair Duro FR-HD  
Solvac 1535G  
Staysol FR  
Sunsafe F  
Union FR Fluid  
Union Soluble Oil HD  
Veedol Auburn FRH  
Veedol Auburn FRH Concentrate

\*\*See CAUTION on page 000 for maximum fluid temperatures and limiting ambient temperatures.

### WATER AND GLYCOL SOLUTION

Maximum fluid temperature recommendation\*\*

HOSE CLASSIFICATIONS (SEE PAGE 176)

	1	2	3	4
H	+200°F	+250°F	+150°F	200°F
LP	+200°F	+250°F	+150°F	200°F

#### Fluid Name

Chem-Trend HF-18  
Chem-Trend HF-20  
Chevron Glycol FR Fluids  
Citgo Glycol FR Fluids  
Citgo Glycol FR-20 XD  
Citgo Pacemaker  
Dasco FR 150  
Dasco FR 200  
Dasco FR 200 B  
Dasco FR 310  
Fyrguard 150  
Fyrguard 200  
Fyre-Safe 225  
Gulf FR Fluid G-200  
Gulf FR Fluid – G Series  
Houghto-Safe 271  
Houghto-Safe 416  
Houghto-Safe 520  
Houghto-Safe 525  
Houghto-Safe 616  
Houghto-Safe 620  
Houghto-Safe 625  
Houghto-Safe 640  
Hydra Safe 620  
Hydra Safe 625  
Hydraulic Safety Fluid 200  
Hydraulic Safety Fluid 300  
Hyspin AF-1  
Hyspin AF-2  
Hyspin AF-3

Maxmul  
Maxmul FR  
Melsyn 200  
Melsyn Glycol FR  
Nyvac FR Fluid  
Nyvac FR 200 Fluid

Nyvac 20 (WG)  
Nyvac 30 (WG)  
Park Water Glycol Hydraulic Fluid  
Pennzoil Fluid FR 2X  
Quintolubric 700 Series  
Santosafe W/G 15  
Santosafe W/G 20  
Santosafe W/G 30  
Standard Glycol FR #15  
Standard Glycol FR #20  
Standard Glycol FR #25  
Ucon Hydrolube 150 CP  
Ucon Hydrolube 200 CP  
Ucon Hydrolube 275 CP  
Ucon Hydrolube 300 CP  
Ucon Hydrolube 550 CP  
Ucon Hydrolube 900 CP  
Ucon Hydrolube 150 DB  
Ucon Hydrolube 275 DB  
Ucon Hydrolube 150 LT  
Ucon Hydrolube 200 LT  
Ucon Hydrolube 275 LT  
Ucon Hydrolube 300 LT  
Ucon M-1  
Ucon Hydrolube 200 NM  
Ucon Hydrolube 300 NM

This chart is intended for reference use only. The information in this chart pertains strictly to material compatibility and is not intended to be used as an application guide. For information on specific applications not included in this catalog, please contact Eaton.

# Technical Data

## Fluid Compatibility

Straight Phosphate-Ester (FR)	Gulf FR Fluid P-40
Maximum fluid temperature recommendation**	Gulf FR Fluid P-43
	Gulf FR Fluid P-45
	Gulf FR Fluid P-47
HOSE CLASSIFICATIONS (SEE PAGE 176)	Houghto-Safe 1010
<u>1 2 3 4</u>	Houghto-Safe 1055
H U +400°F +200°F 180°F	Houghto-Safe 1115
LP U +400°F +200°F 200°F	Houghto-Safe 1120
Fluid Name	Houghto-Safe 1130
FR Fluids	Pydraul 10E
Fyrquel 90	Pydraul 29-E-LT
Fyrquel 150	Pydraul 30-E
Fyrquel 220	Pydraul 50-E
Fyrquel 300	Pydraul 65-E
Fyrquel 550	Pydraul 115-E
Fyrquel 1000	Pyrogard 51
Fyrquel 150 R & O	Pyrogard 53
Fyrquel 220 R & O	Pyrogard 55
Fyrquel 550 R & O	Safetytex 215
Gulf FR Fluid P-37	Univis P12

### PHOSPHATE-ESTER AND PETROLEUM-OIL

Maximum fluid temperature recommendation\*\*

HOSE CLASSIFICATIONS (SEE PAGE 176)

<u>1 2 3 4</u>
H U +400°F +200°F 180°F
LP U +400°F +200°F 200°F

Fluid Name

Citgo Synthetic Oil-Fire Resistant  
 Fyrtek 290  
 Fyrtek MF  
 Pydraul 230-C  
 Pydraul 312-C  
 Pydraul 540-C  
 Stauffer SCC 7204

### ESTER BLEND TURBINE OILS

Maximum fluid temperature recommendation\*\*

Fluid Name

Stauffer Jet I

HOSE CLASSIFICATIONS (SEE PAGE 176)

<u>1 2 3 4</u>
H +200°F +400°F 225°F
LP +200°F +400°F 250°F

Stauffer Jet II

### SILICONE OILS

Maximum fluid temperature recommendation\*\*

HOSE CLASSIFICATIONS (SEE PAGE 176)

<u>1 2 3 4</u>
H D D D D
LP +250°F +450°F +200°F 300°F

Fluid Name

Dow Corning 200 Fluid (100CS)  
 Dow Corning QF1-2023  
 Dow Corning 4-3600  
 Dow Corning 3-3672

### POLYOL-ESTER

Maximum fluid temperature recommendation\*\*

Fluid Name

Quintolubric 822 Series

HOSE CLASSIFICATIONS (SEE PAGE 176)

<u>1 2 3 4</u>
H +200°F +400°F +200°F 300°F
FLP +250°F +450°F +200°F 300°F

\*\*See CAUTION on page 000 for maximum fluid temperatures and limiting ambient temperatures.

This chart is intended for reference use only. The information in this chart pertains strictly to material compatibility and is used as an application guide. For information on specific applications not included in this catalog, please contact Eaton.

# Technical Data

## SAE Recommended Practice

**Selection, installation and maintenance of hose and assemblies Ñ SAE J1273 November 1991**

### SAE recommended practice

The following recommendations on selection, installation and maintenance of hose assemblies were established by the S.A.E. in 1991. Please read these general instructions carefully. More detailed information on many of these subjects is covered in this catalog.

1. Scope—Hose (also includes hose assemblies) has a finite life and there are a number of factors which will reduce its life.

This recommended practice is intended as a guide to assist system designers and/or users in the selection, installation and maintenance of hose.

The designers and users must make a systematic review of each application and then select, install and maintain the hose to fulfill the requirements of the application.

The following are general guidelines and are not necessarily a complete list.

**WARNING: IMPROPER SELECTION, INSTALLATION OR MAINTENANCE MAY RESULT IN PREMATURE FAILURES, BODILY INJURY OR PROPERTY DAMAGE.**

### 2. References

2.1 Applicable Documents—The following publications form a part of this specification to the extent specified herein. The latest issue of SAE publications shall apply.

2.1.1 SAE PUBLICATIONS—Available from SAE, 400 Commonwealth Drive, Warrendale, PA 15096-0001.

J516—Hydraulic  
Hose Fittings

J517—Hydraulic Hose

3. Selection—The following is a list of factors which must be considered before final hose selection can be made.

3.1 Pressure—After determining the system pressure, hose selection must be made so that the recommended maximum operating pressure is equal to or greater than the system pressure. Surge pressures higher than the maximum operating pressure will shorten hose life and must be taken into account by the hydraulic designer.

3.2 Suction—Hoses used for suction applications must be selected to ensure the hose will withstand the negative pressure of the system.

3.3 Temperature—Care must be taken to ensure that fluid and ambient temperatures, both static and transient, do not exceed the limitations of the hose. Special care must be taken when routing near hot manifolds.

3.4 Fluid Compatibility—Hose selection must assure compatibility of the hose tube, cover and fittings with the fluid used. Additional caution must be observed in hose selection for gaseous applications.

3.5 Size—Transmission of power by means of pressurized fluid varies with pressure and rate of flow. The size of the components must be adequate to keep pressure losses to a minimum and avoid damage to the hose due to heat generation or excessive turbulence.

3.6 Routing—Attention must be given to optimum routing to minimize inherent problems.

3.7 Environment—Care must be taken to insure that the hose and fittings are either compatible with or protected from the environment to which they are exposed. Environmental conditions such as ultraviolet light, ozone, salt water, chemicals and air pollutants can cause degradation

and premature failure and, therefore, must be considered.

3.8 Mechanical Loads—External forces can significantly reduce hose life. Mechanical loads which must be considered include excessive flexing, twist, kinking, tensile or side loads, bend radius and vibration. Use of swivel-type fittings or adapters may be required to insure no twist is put into the hose. Unusual applications may require special testing prior to hose selection.

3.9 Abrasion—While hose is designed with a reasonable level of abrasion resistance, care must be taken to protect the hose from excessive abrasion which can result in erosion, snagging and cutting of the hose cover. Exposure of the reinforcement will significantly accelerate hose failure.

3.10 Proper End Fitting—Care must be taken to ensure proper compatibility exists between the hose and coupling selected based on the manufacturer's recommendations substantiated by testing to industry standards such as SAE J517. End fitting components from one manufacturer are usually not compatible with end fitting components supplied by another manufacturer (i.e., using a hose fitting nipple from one manufacturer with a hose socket from another manufacturer). It is the responsibility of the fabricator to consult the manufacturer's written instructions or the manufacturer directly for proper end fitting componentry.

3.11 Length—When establishing proper hose length, motion absorption, hose length changes due to pressure, as well as hose and machine tolerances, must be considered.

3.12 Specifications and

Standards—When selecting hose, government, industry and manufacturers' specifications and recommendations must be reviewed as applicable.

3.13 Hose Cleanliness—Hose components vary in cleanliness levels. Care must be taken to ensure that the assemblies selected have an adequate level of cleanliness for the application.

3.14 Electrical Conductivity—Certain applications require that hose be nonconductive to prevent electrical current flow. Other applications require the hose to be sufficiently conductive to drain off static electricity. Hose and fittings must be chosen with these needs in mind.

4. Installation—After selection of proper hose, the following factors must be considered by the installer.

4.1 Pre-Installation Inspection—Prior to installation, a careful examination of the hose must be performed. All components must be checked for correct style, size and length. In addition, the hose must be examined for cleanliness, I.D. obstructions, blisters, loose cover, or any other visible defects.

4.2 Follow Manufacturers' Assembly Instructions—Hose assemblies may be fabricated by the manufacturer, an agent for or customer of the manufacturer or by the user. Fabrication of permanently attached fittings to hydraulic hose requires specialized assembly equipment. Field-attachable fittings (screw style and segment clamp style) can usually be assembled without specialized equipment although many manufacturers provide equipment to assist in the operation.

SAE J517 hose from one manufacturer is usually not com-

# Technical Data

## SAE Recommended Practice

patible with SAE J516 fittings supplied by another manufacturer. It is the responsibility of the fabricator to consult the manufacturer's written assembly instructions or the manufacturer's written instructions directly before intermixing hose and fittings from two manufacturers. Similarly, assembly equipment from one manufacturer is usually not interchangeable with that of another manufacturer. It is the responsibility of the fabricator to consult the manufacturer's written instructions or the manufacturer directly for proper assembly equipment. Always follow the manufacturer's instructions for proper preparation and fabrication of hose assemblies.

**4.3 Minimum Bend Radius—**Installation at less than minimum bend radius may significantly reduce hose life. Particular attention must be given to preclude sharp bending at the hose/fitting juncture.

**4.4 Twist Angle and Orientation—**Hose installations must be such that relative motion of machine components produces bending of the hose rather than twisting.

**4.5 Securement—**In many applications, it may be necessary to restrain, protect or guide the hose to protect it from damage by unnecessary flexing, pressure surges and contact with other mechanical components. Care must be taken to insure such restraints do not introduce additional stress or wear points.

**4.6 Proper Connection of Ports—**Proper physical installation of the hose requires a correctly installed port connection while insuring that no twist or torque is put into the hose.

**4.7 Avoid External Damage—**Proper installation is not complete without ensuring that tensile loads, side loads, kinking, flattening, potential abrasion, thread damage, or damage to sealing surfaces are corrected or eliminated.

**4.8 System Check Out—**After completing the installation, all air entrapment must be eliminated and the system pressurized to the maximum system pressure and checked for proper function and freedom from leaks.

**NOTE: Avoid potential hazardous areas while testing.**

**5. Maintenance—**Even with proper selection and installation, hose life may be significantly reduced without a continuing maintenance program. Frequency should be determined by the severity of the application and risk potential. A maintenance program should include the following as a minimum.

**5.1 Hose Storage—**Hose products in storage can be affected adversely by temperature, humidity, ozone, sunlight, oils, solvents, corrosive liquids and fumes, insects, rodents and radioactive materials. Storage areas should be relatively cool and dark and free of dust, dirt, dampness and mildew.

**5.2 Visual Inspection—**Any of the following conditions requires replacement of the hose:

- (a) Leaks at fitting or in hose (leaking fluid is a fire hazard)
- (b) Damaged, cut or abraded cover (any reinforcement exposed)
- (c) Kinked, crushed, flattened or twisted hose
- (d) Hard, stiff, heat cracked or charred hose
- (e) Blistered, soft, degraded or loose cover
- (f) Cracked, damaged or badly corroded fittings
- (g) Fitting slippage on hose

**5.3 Visual Inspection—**The following items must be tightened, repaired or replaced as required:

- (a) Leaking port conditions
- (b) Clamps, guards, shields
- (c) Remove excessive dirt buildup
- (d) System fluid level, fluid type, and any air entrapment

**5.4 Functional Test—**Operate the system at maximum operating pressure and check for possible malfunctions and freedom from leaks.

**NOTE: Avoid potential hazardous areas while testing.**

**5.5 Replacement Intervals—**Specific replacement intervals must be considered based on previous service life, government or industry recommendations, or when failures could result in unacceptable down time, damage or injury risk.

# Technical Data

## Flow Capacities

### Pressure Drop

#### Flow capacities of hose assemblies at suggested flow velocities

The chart below is designed and provided as an aid in the determination of the correct hose size.

#### Example:

At 13 U.S. gallons per minute, what is proper hose size within the suggested velocity range for pressure lines?

#### Solution:

Locate 13 U.S. gallons per minute in the left hand column and 10 feet per second in the right hand column (the center of the suggested velocity range for pressure lines). Lay a straightedge across the two points. The inside diameter is shown in the center column nearest the straightedge.

For suction hose, follow the same procedure except use suggested velocity range for pump inlet lines in the right hand column.

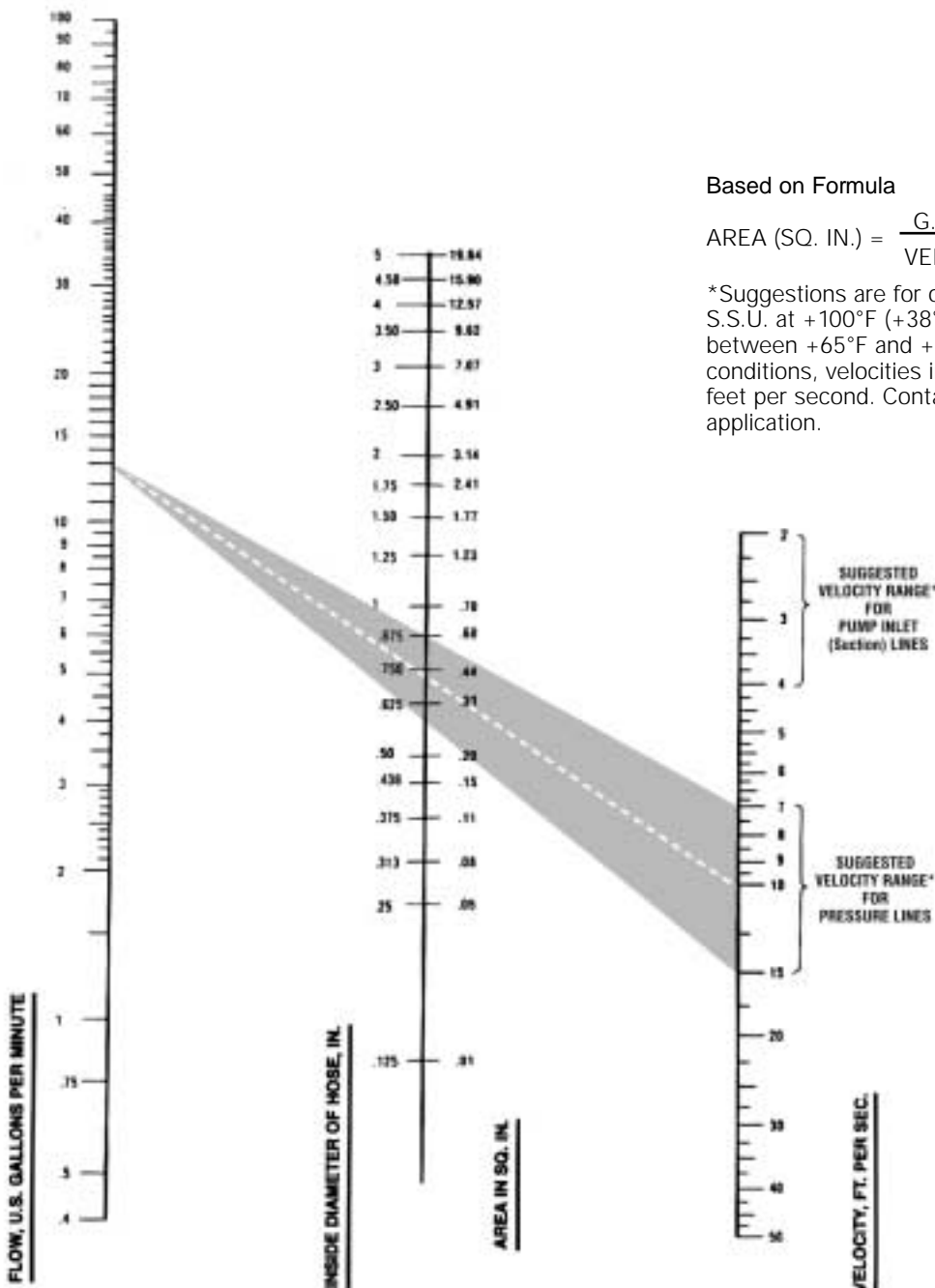

#### Based on Formula

$$\text{AREA (SQ. IN.)} = \frac{\text{G.P.M.} \times 0.3208}{\text{VELOCITY (FT./SEC.)}}$$

\*Suggestions are for oils having a maximum viscosity of 315 S.S.U. at +100°F (+38°C) and operating at temperatures between +65°F and +155°F (+54°C to +69°C). Under certain conditions, velocities in pressure lines can be increased up to 25 feet per second. Contact Eaton with specific information on your application.

#### To convert

U.S. gallons into Imperial gallons multiply U.S. gallons by 0.83267. Imperial gallons into U.S. gallons multiply Imperial gallons by 1.20095.

U.S. gallons to litres multiply by 3.785. Litres to U.S. gallons, multiply by 0.2642.

# Technical Data

## Flow Capacities

### Pressure Drop

\* Pressure drop in psi (pounds per square inch)/gpm (gallons per minute) for 10 feet of hose (smooth bore) without fittings. Fluid specification: Specific gravity = .85; Viscosity =  $\nu$  = 20 centistokes (C.S.), (20 C.S. = 97 S.S.U.).

#### Hose pressure drop

Hose Dash Size @		-04	-05	-06	-08	-10	-12-16	-20	-24	-32	-40	-48												
Hose I.D. (inches)	$\nu$	.19	.25	.25	.31	.31	.38	.41	.50	.50	.63	.63	.875	1.00	1.13	1.25	1.38	1.50	1.81	2.00	2.38	3.00		
U.S. Gallons per minute	.25	10	3.1	3.1																				
	.50	19	6	6	2.7	2.7																		
	1	40	12	12	5.5	5.5	2.4																	
	2	95	24	24	10	10	4.8	3.5																
	3	185	46	46	17	17	7	5	2.2	2.2														
	4		78	78	29	29	12	8	3	3	1.2	1.2												
	5		120	120	44	44	18	12	4.5	4.5	1.6	1.6	.72											
	8				95	95	39	26	10	10	3.6	3.6	1.6											
	10					59	40	15	15	5.7	5.7	2.1	.55											
	12					80	52	20	20	7.2	7.2	2.1	.65	.75	.43									
	15						75	30	30	10	10	4.2	2.2	1.2	.67	.38								
	18						107	40	40	15	15	6.3	1.5	.70	.55	.35								
	20							49	49	19	19	8.3	4.2	1.1	.65	.43	.27							
	25							72	72	26	26	11.5	5.5	3	1.6	1	.64	.40	.17					
	30									34	34	14	7	3.6	2.2	1.3	.80	.52	.22	14				
	35									47	47	19	9.5	5	2.8	1.7	1.1	.70	.27	18				
	40											25	12	6.5	3.4	2.2	1.4	.90	.38	.24				
	50											36	17	9	5.3	3.3	2	1.3	.54	.35	.15			
	60											50	23	12	7.5	4.4	2.8	1.8	.75	.45	.20			
	70												31	17	9.3	6	3.8	2.4	1	.65	.30			
80												38	21	12	7.1	4.6	3	1.2	.76	.34	.11			
90												49	27	15	9	5.9	3.8	1.5	1	.45	.13			
100													33	19	12	7	4.7	1.9	1.3	.55	.18			
150													60	36	22	13	8.5	3.4	2.2	1	.33			
200															36	23	15	6	3.9	1.7	.55			
250															54	33	22	8.5	5.3	2.5	.75			
300																45	29	12	7.5	4	1.1			
400																	51	21	14	6.5	2.2			
500																		32	20	10	3			
800																				18	5			
1000																						10		

\*Pressure drop values listed are typical of many petroleum based hydraulic oils at approximately +100°F (+38°C). Differences in fluids, fluid temperature and viscosity can increase or decrease actual pressure drop compared to the values listed.

#### To convert

U.S. gallons into Imperial gallons multiply U.S. gallons by 0.83267. Imperial gallons into U.S. gallons multiply Imperial gallons by 1.20095. U.S. gallons to litres multiply by 3.785. Litres to U.S. gallons, multiply by 0.2642.

## Technical Data

### Service Life

### Routing/ Installation

#### Service life factors

Hose assemblies, like other products, have

# Technical Data

## Service Life Routing/ Installation

### Hose routing and installation

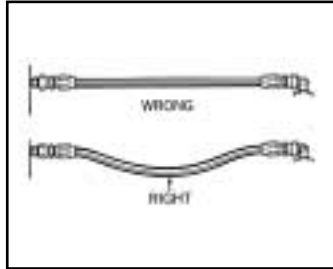

Under pressure, a hose may change in length. Always provide some slack in the hose to allow for this shortening or elongation (However, excessive slack in hose lines may cause poor appearance).

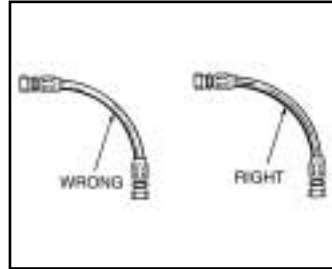

If a hose is installed with a twist in it, operating pressures tend to force it straight. This can loosen the fitting nut. Twisting can cause reinforcement separation and the hose could burst at the point of strain.

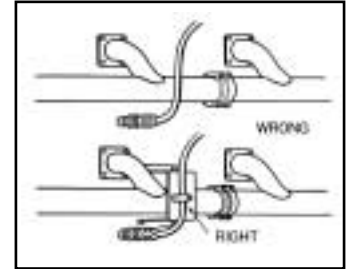

When hose lines pass near an exhaust manifold or other heat source, they should be insulated by a heat resistant boot, firesleeve or a metal baffle. In any application, brackets and clamps keep hoses in place and reduce abrasion. For installations where abrasion to hose cover cannot be prevented with the use of clamps or brackets, a steel protective coil or abrasion resistant sleeve should be placed over the hose.

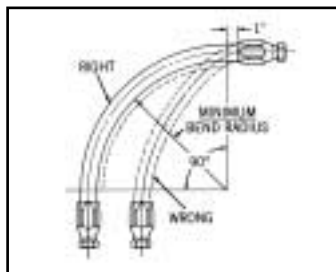

At bends, provide sufficient hose so that it does not have a bend radius less than its recommended minimum bend radius. Too tight a bend may kink the hose and restrict or stop the fluid flow. In many cases the proper use of adapters and hose fittings can eliminate tight bends or kinks.

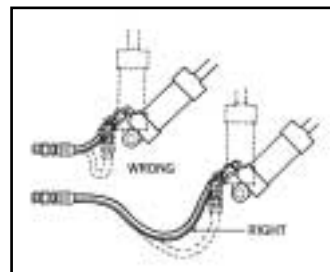

In applications where there is considerable vibration or flexing, allow additional hose length. The metal hose fittings, of course, are not flexible, and proper installation protects metal parts from undue stress, and avoids kinks in the hose.

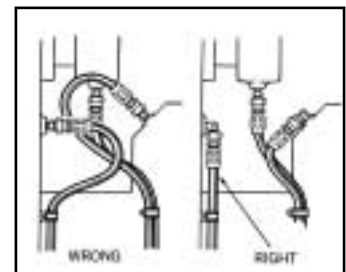

When 90° adapters were used, this assembly became neater-looking and easier to inspect and maintain. It uses less hose, too!

# Technical Data

## Cleaning, Inspection, Testing, and Storage



Clean



Inspect



Proof test-hydrostatic



Proof test-pneumatic

### Maintenance

Hose assemblies in operation should be inspected frequently for leakage, kinking, abrasion, corrosion or any other signs of wear or damage. Worn or damaged hose assemblies should be replaced immediately.

### Clean

Clean assembly by blowing out with clean compressed air. Assemblies may be rinsed out with mineral spirits if the tube stock is compatible with oil, otherwise hot water at +150°F max. may be used. Consult Eaton for special cleaning equipment.

### Inspect

Examine hose assembly internally for cut or bulged tube, obstructions and cleanliness. For segment style fittings, be sure that the hose butts up against the nipple shoulder; band and retaining ring are properly set and tight, and segments are properly spaced. Check for proper gap between nut and socket or hex and socket. Nuts should swivel freely. Check the layline of the hose to be sure that the assembly is not twisted. Cap the ends of the hose with plastic covers to keep clean.

### Proof test (hydrostatic)

The hose assembly should be hydrostatically tested at twice the recommended working pressure of the hose.

Test pressure should be held for no less than 1 minute and no more than 5 minutes. When test pressure is reached, visually inspect hose assembly for:

- a) Any leaks or signs of weakness.
- b) Any movement of the hose fitting in relation to the hose. Any of these defects are cause for rejection.

### Caution:

Testing should be conducted in approved test stands with adequate guards to protect the operator.

(See Assembly Equipment Section for Eaton Aeroquip Proof Test Stands.)

### Proof test (pneumatic)

Hose assemblies intended for gas or air service should be tested with air or nitrogen at 100 psi with the assembly immersed in water. Random bubbles may appear over the hose and fitting area when assembly is first pressurized. This should not be construed as a defect. However, if the bubbles persist in forming at a steady rate at any particular point on the hose, the assembly should be rejected.

### Caution:

Testing should be conducted in approved test stands with adequate guards to protect the operator.

### Storage and handling

Hose should be stored in a dark, dry atmosphere away from electrical equipment, and the temperature should not exceed +90°F. Storage in the original shipping container is preferred.

# Technical Data

## Analyzing Failures

Everyone in maintenance encounters hose failures. Normally, there is no problem. The hose is replaced and the equipment goes back in operation. Occasionally, the failures come too frequently – the same equipment with the same problems keep popping up. At this point the task is to determine and correct the cause of these repeated failures.

### Improper application

Beginning with the most obvious, the most common cause of hose failures – improper application – compare the hose specifications with the requirements of the application.

Pay particular attention to the following areas:

1. The maximum operating pressure of the hose.
2. The recommended temperature range of the hose.
3. Whether the hose is rated for vacuum service.
4. The fluid compatibility of the hose.

Check all of these areas against the requirements of the application. If they don't match up, you need to select another hose. It's a good idea at this point to call on your local hose distributor for assistance in selecting the proper hose. Eaton's distributors, for example, are well equipped to perform this service for you.

Distributor personnel attend special training courses in hydraulics and hose application conducted by the company. Or, if your problem is particularly difficult, the distributor can call on the services of Eaton's Field Engineering Staff. The company will send in a hose and hydraulic specialist to study the problem and come up with a solution.

### Improper assembly and installation

The second major cause of premature hose failure is improper assembly and installation procedures. This can involve anything from using the wrong fitting on a hose, to poor routing of the hose.

Eaton provides excellent training material that you can use to combat this problem. A little time spent in training your maintenance people could pay big dividends in reduced downtime.

You can make use of the material available from Eaton to improve your hose assembly and installation techniques.

This material is available free from Eaton, 14615 Lone Oak Road, Eden Prairie, MN 55317. Fax: 952-937-7394.

### External damage

External damage can range from abrasion and corrosion, to hose that is crushed by a lift truck. These are problems that can normally be solved simply once the cause is identified. The hose can be re-routed or clamped, or a fire sleeve or abrasion guard can be used.

In the case of corrosion, the answer may be as simple as changing to a hose with a more corrosion resistant cover or re-routing the hose to avoid the corrosive element.

### Faulty equipment

Too frequent or premature hose failure can be the symptom of a malfunction in your equipment. This is a factor that should be considered since prompt corrective action can sometimes avoid serious and costly equipment breakdown. Reprints of an article on "Troubleshooting Hydraulic Systems," which tells you how to spot problems in a hydraulic system are available from Eaton.

### Faulty hose

Occasionally a failure problem will lie in the hose itself. The

most likely cause of a faulty rubber hose is old age. Check the lay line on the hose to determine the date of manufacture. (2Q99 means second quarter 1999.) The hose may have exceeded its recommended shelf life. If you suspect that the problem lies in the manufacture of the hose (and don't jump to this conclusion until you have exhausted the other possibilities) contact your distributor. Given effective quality control methods, the odds of a faulty batch of hose being released for sale are extremely small. So make sure that you haven't overlooked some other problem area.

### Analyzing failures

A physical examination of the failed hose can often offer a clue to the cause of the failure. Following are 22 symptoms to look for along with the conditions that could cause them:

#### 1. Symptom:

The hose tube is very hard and has cracked.

#### Cause:



Heat has a tendency to leach the plasticizers out of the tube. This is a material that gives the hose its flexibility or plasticity.

Aerated oil causes oxidation to occur in the tube. This reaction of oxygen on a rubber product will cause it to harden. Any combination of oxygen and heat will greatly accelerate the hardening of the hose tube. Cavitation occurring inside the tube would have the same effect.

#### 2. Symptom:

The hose is cracked both exter-

nally and internally but the elastomeric materials are soft and flexible at room temperature.

#### Cause:



The probable reason is intense cold ambient conditions while the hose was flexed. Most standard hoses are rated to -40°F (-40°C). Some AQP hoses are rated at -55°F (-49°C). Military specified hoses are generally rated to -65°F (-54°C). PTFE hose is rated to -100°F (-73°C). Some Polyon thermoplastic hoses are rated at -65°F (-54°C).

#### 3. Symptom:

The hose has burst and examination of the wire reinforcement after stripping back the cover reveals random broken wires the entire length of the hose.

#### Cause:



This would indicate a high frequency pressure impulse condition. SAE impulse test requirements for a double wire braid reinforcement are 200,000 cycles at 133% of recommended working pressure. The SAE impulse test requirements for a four spiral wrapped reinforcement (100R-9) are 300,000 cycles at 133% maximum operating and at +200°F (93°C). If the extrapolated impulses in a system amount to over a million in a relatively short time a spiral reinforced hose would be the better choice.

# Technical Data

## Analyzing Failures

### 4. Symptom:

The hose has burst, but there is no indication of multiple broken wires the entire length of the hose. The hose may have burst in more than one place.



### Cause:

This would indicate that the pressure has exceeded the minimum burst strength of the hose. Either a stronger hose is needed or the hydraulic circuit has a malfunction which is causing unusually high pressure conditions.

### 5. Symptom:

Hose has burst. An examination indicates that the wire braid is rusted and the cover has been cut, abraded or deteriorated badly.



### Cause:

The primary function of the cover is to protect the reinforcement. Elements that may destroy or remove the hose covers are:

1. Abrasion
2. Cutting
3. Battery Acid
4. Steam Cleaners
5. Chemical Cleaning Solutions
6. Muriatic Acid (for cement clean-up)
7. Salt Water
8. Heat
9. Extreme Cold

Once the cover protection is gone the wire reinforcement is susceptible to attack from moisture or other corrosive matter.

### 6. Symptom:

Hose has burst on the outside

bend and appears to be elliptical in the bent section. In the case of a pump supply line, the pump is noisy and very hot. The exhaust line on the pump is hard and brittle.

### Cause:

Violation of the minimum bend radius is most likely the problem in both cases. Check the minimum bend radius and make sure that the application is within specifications. In the case of the pump supply line partial collapse of the hose is causing the pump to cavitate creating both noise and heat. This is a most serious situation and will result in catastrophic pump failure if not corrected.

### 7. Symptom:

Hose appears to be flattened out in one or two areas and appears to be kinked. It has burst in this area and also appears to be twisted.



### Cause:

Torquing of a hydraulic control hose will tear loose the reinforcement layers and allow the hose to burst through the enlarged gaps between the braided plaits of wire strands. Use swivel fittings or joints to be sure there is no twisting force on a hydraulic hose.

### 8. Symptom:

Hose type has broken loose from the reinforcement and piled up at the end of the hose. In some cases it may protrude from the end of the hose fitting.

### Cause:

The probable cause is high vacuum or the wrong hose for vacuum service. No vacuum is recommended for double wire braid, 4 and 6 spiral wire hose unless some sort of internal coil support is used. Even though a hose is rated for vacuum service, if it is

kinked, flattened out or bent too sharply this type of failure may occur.

### 9. Symptom:

Hose has burst about six to eight inches away from the end fitting. The wire braid is rusted. There are no cuts or abrasions of the outer cover.

### Cause:

Improper assembly of the hose end fitting allowing moisture to enter around the edge of the fitting socket. The moisture will wick through the reinforcement. The heat generated by the system will drive it out around the fitting area but six to eight inches away it will be entrapped between the inner line and outer cover causing corrosion of the wire reinforcement.

### 10. Symptom:

There are blisters in the cover of the hose. If one pricks the blisters, oil will be found in them.

### Cause:

A minute pin hole in the hose tube is allowing the high pressure oil to seep between it and the cover. Eventually it will form a blister wherever the cover adhesion is weakest. In the case of a screw together reusable fitting insufficient lubrication of the hose and fitting can cause this condition because the dry tube will adhere to the rotating nipple and tear enough to allow seepage. Faulty hose can also cause this condition.

### 11. Symptom:

Blistering of the hose cover where a gaseous fluid is being used.



### Cause:

The high pressure gas is effusing through the hose tube, gathering under the cover and eventually forming a blister wherever the adhesion is weakest. Specially

constructed hoses are available for high pressure gaseous applications. Your supplier can advise you on the proper hose to use in these cases.

### 12. Symptom:

Fitting blew off of the end of the hose.

### Cause:

It may be that the wrong fitting has been put on the hose. Recheck manufacturer's specifications and part numbers.

In the case of a crimped fitting, the wrong machine setting may have been used resulting in over or undercrimping. The socket of a screw together fitting for multiple wire braided hose may be worn beyond its tolerance. The swaging dies in a swaged hose assembly may be worn beyond the manufacturer's tolerances.

The fitting may have been applied improperly to the hose. Check manufacturer's instructions. The hose may have been installed without leaving enough slack to compensate for the possible 4% shortening that may occur when the hose is pressurized. This will impose a great force on the fitting. The hose itself may be out of tolerance.

### 13. Symptom:

The tube of the hose is badly deteriorated with evidences of extreme swelling. In some cases the hose tube may be partially "washed out."



### Cause:

Indications are that the hose tube is not compatible with the agent being carried. Even though the agent is normally compatible, the addition of heat can be the catalyst that can cause inner liner dete-

# Technical Data

## Analyzing Failures

rioration. Consult your hose supplier for a compatibility list or present him with a sample of the fluid being conducted by the hose for analysis. Make sure that the operating temperatures both internal and external do not exceed recommendations.

### 14. Symptom:

Hose has burst. The hose cover is badly deteriorated and the surface of the rubber is crazed.

### Cause:

This could be simply old age. The crazed appearance is the effect of weathering and ozone over a period of time. Try to determine the age of the hose. Some manufacturers print or emboss the cure date on the outside of the hose. As an example, Eaton Aeroquip hose would show "4Q73" which would mean that the hose was manufactured during the fourth quarter (October, November or December) of 1973.

### 15. Symptom:

Hose is leaking at the fitting because of a crack in the metal tube adjacent to the braze on a split flange head.

### Cause:

Because the crack is adjacent to the braze and not in the braze, this is a stress failure brought on by a hose that is trying to shorten under pressure and has insufficient slack in it to do so. We have cured dozens of these problems by lengthening the hose assembly or changing the routing to relieve the forces on the fitting.

### 16. Symptom:

A spiral reinforced hose has burst and literally split open with the wire exploded out and badly entangled.



### Cause:

The hose is too short to accommodate the change in length occurring while it is pressured.

### 17. Symptom:

Hose is badly flattened out in the burst area. The tube is very hard down stream of the burst but appears normal up stream of the burst.



### Cause:

The hose has been kinked either by bending it too sharply or by squashing it in some way so that a major restriction was created. As the velocity of the fluid increases through the restriction the pressure decreases to the vaporization point of the fluid being conveyed. This is commonly called cavitation, and causes heat and rapid oxidation to take place which hardens the tube of the hose down stream of the restriction.

### 18. Symptom:

Hose has not burst but it is leaking profusely. A bisection of the hose reveals that the tube has been gouged through to the wire braid for a distance of approximately two inches.

### Cause:

This failure would indicate that erosion of the hose tube has taken place. A high velocity needle-like fluid stream being emitted from an orifice and impinging at a single point on the hose tube will hydraulically remove a section of it. Be sure that the hose is not bent close to a port that is orificed.

In some cases where high velocities are encountered particles in the fluid can cause considerable erosion in bent sections of the hose assembly.

### 19. Symptom:

The hose fitting has been pulled out of the hose. The hose has been considerably stretched out in length. This may not be a high pressure application.

### Cause:

Insufficient support of the hose. It is very necessary to support very long lengths of hose, especially if they are vertical. The weight of the hose along with the weight of the fluid inside the hose in these cases is being imposed on the hose fitting. This force can be transmitted to a wire rope or chain by clamping the hose to it much like the utilities support bundles of wire from pole to pole. Be sure to leave sufficient slack in the hose between clamps to make up for the possible 4% shortening that could take place when the hose is pressurized.

### 20. Symptom:

The hose has not burst but it is leaking profusely. An examination of the bisected hose reveals that the tube has burst inwardly.

### Cause:

This type of failure is commonly referred to as hose tube blow down. It is usually associated with very low viscosity fluids such as air, nitrogen, freon and other gases. What happens is that under high pressure conditions the gases will effuse into the pores of the hose tube charging them up like miniature accumulators. If the pressure is very suddenly reduced to zero, the entrapped gases literally explode out of the tube often tearing holes in it. In some hose constructions a second hose tube made from a plastic such as nylon, is inserted into the hose.

A small leak will allow the gaseous fluid to seep between the two inner liners and when the pressure is reduced to zero the innermost liner will collapse because of the entrapped pressure around its outer diameter.

### 21. Symptom:

PTFE hose assembly has collapsed internally in one or more places.

### Cause:

One of the most common causes for this is improper handling of the PTFE assembly. PTFE is a thermoplastic material which is not rubber-like. When bent sharply it simply collapses. This type of collapse is localized in one area and is radial. When the PTFE tube is folded longitudinally in one or more places this could be the result of heat (which softens the hose tube) along with vacuum conditions inside of it. Because of the additional tension of the wire braid reinforcement inherent with this type of hose, there is always a radial tension on the tube trying to push it in. Rapid cycling from a very hot agent in the hose to a very cold agent in the hose can produce the same type of failure. Eaton offers an internal support coil that will eliminate this problem.

### 22. Symptom:

A PTFE hose assembly has developed a pin hole leak or several pin hole leaks.

### Cause:

This situation occurs when a petroleum base fluid, with a low viscosity, is flowing at a high velocity. This condition can generate high voltage due to static electricity. The high voltage is seeking a ground connection and the only ground connection available is the braided stainless steel reinforcement. This causes an electric arc, which penetrates through the PTFE tube as it travels to the reinforcement. Specially constructed PTFE tubes are available that have enough carbon black in them so as to be conductive. They will "drain off" the static electricity and preclude this problem.

# Technical Data

## How to Identify Fluid Connectors

### Measuring Tools

Order part number FT1341 for Eaton Aeroquip Tool Kit. A seat angle gauge, thread pitch gauge and an I.D./O.D. caliper are necessary to make accurate measurements of commonly used connectors. Eaton Aeroquip offers a unique new caliper that offers the capabilities of both a caliper and a seat angle gauge in one unit.

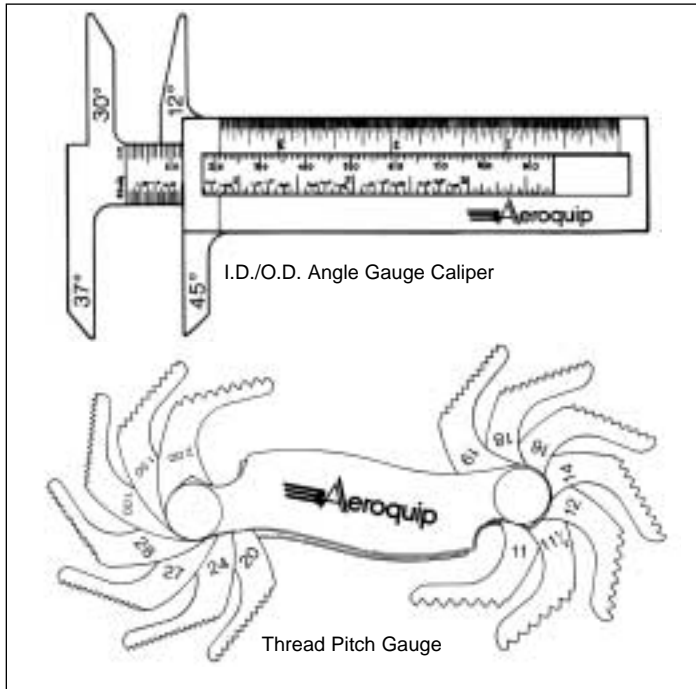

I.D./O.D. Angle Gauge Caliper

Thread Pitch Gauge

### How to Measure Threads

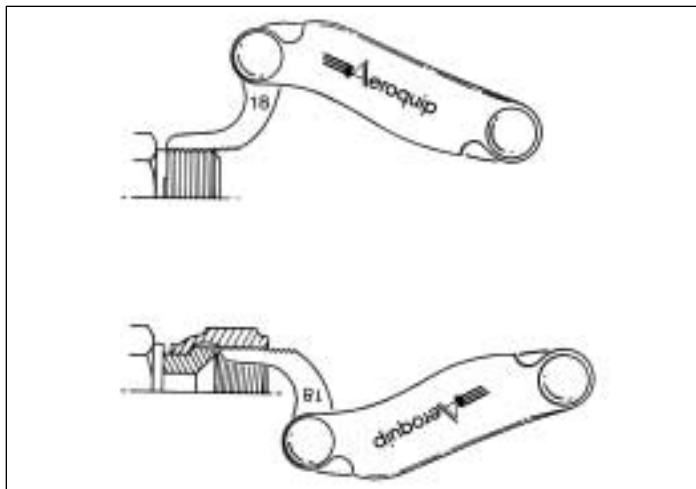

Use a thread pitch gauge to determine the number of threads per inch or the distance between threads in metric connections. Place the gauge on the threads until the fit is snug. Match the measurement to the charts.

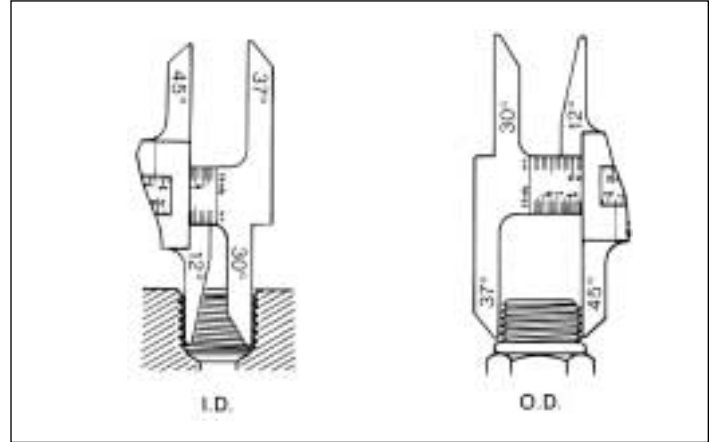

Measure the thread diameter with an I.D./O.D. caliper as shown. Match the measurements to the charts.

### How to Measure Sealing Surface Angles

Female connections are usually measured by inserting the gauge into the connection and placing it on the sealing surface. If the centerlines of the connection and gauge are parallel, the correct angle has been determined.

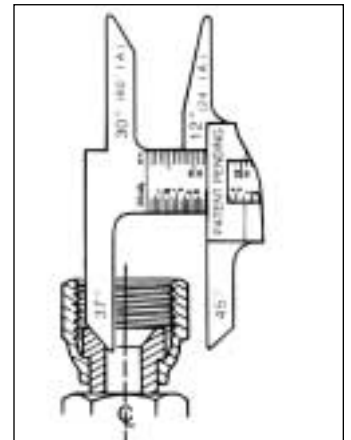

Male flare type connectors are usually measured by placing the gauge on the sealing surface. If the centerlines of the connection and gauge are parallel, the correct angle has been determined.

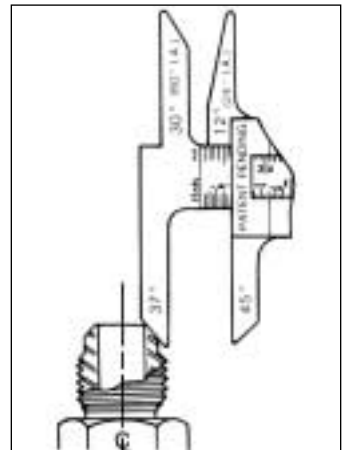

# Technical Data

## Thread Size

### Thread size chart

The following chart is intended as a quick reference guide for thread size by dash size.

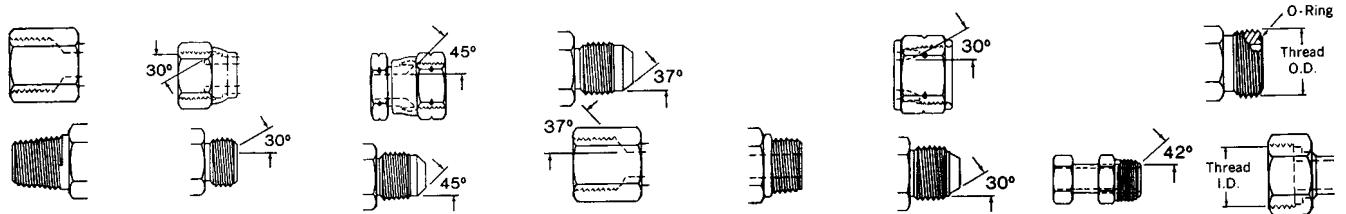

DASH SIZE	N.P.T.F.	N.P.S.M. APPROX. DIA.	SAE 45° AUTO. REFRIG.	SAE 37° (J.I.C.) HYDRAULIC	SAE O-RING BOSS	P.T.T. 30° SAE INVERT. AUTOMOTIVE FLARE	ORS
Ø02	1/8Ø27	1/8Ø27	5/16Ø24	5/16Ø24	5/16Ø24	5/16Ø24	
Ø03			3/8Ø24	3/8Ø24	3/8Ø24	3/8Ø24	
Ø04	1/4Ø18	1/4Ø18	7/16Ø20	7/16Ø20	7/16Ø20	7/16Ø24	9/16Ø18
Ø05			1/2Ø20	1/2Ø20	1/2Ø20	1/2Ø20	
Ø06	3/8Ø18	3/8Ø18	5/8Ø18	9/16Ø18	9/16Ø18	5/8Ø18	11/16Ø16
Ø07			11/16Ø24			11/16Ø18	
Ø08	1/2Ø14	1/2Ø14	3/4Ø16	3/4Ø16	3/4Ø16	3/4Ø18	13/16Ø16
Ø10			7/8Ø14	7/8Ø14	7/8Ø14	7/8Ø18	1Ø14
Ø12	3/4Ø14	3/4Ø14	7/16Ø14	7/16Ø12	7/16Ø12	7/16Ø16	7/16Ø12
Ø14				7/16Ø12	7/16Ø12		
Ø16	1Ø11/2	1Ø11/2		15/16Ø12	7/16Ø12	7/16Ø14	7/16Ø12
Ø20	11/4Ø11/2	11/4Ø11/2		15/8Ø12	7/8Ø12	7/8Ø14	7/8Ø12
Ø24	11/2Ø11/2	11/2Ø11/2		17/8Ø12	7/8Ø12	7/8Ø14	2Ø12
Ø32	2Ø11/2	2Ø11/2		21/2Ø12	21/2Ø12	21/2Ø12	
Ø40	21/2Ø8	21/2Ø8		3Ø12	3Ø12		
Ø48	3Ø8	3Ø8		1/2Ø12	3/2Ø12		

### Through hole dimensions

All dimensions are nominal. In jump size bodies, the minimum through hole dimensions will correspond to the smallest dash size.

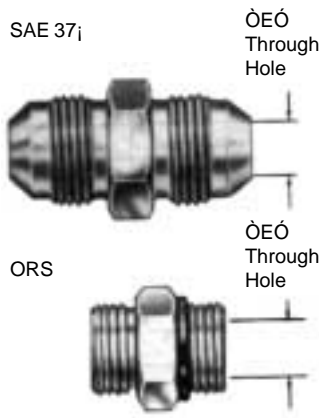

DASH SIZE	"E" THROUGH HOLE	"E" THROUGH HOLE SAE 37° ORS
Ø03	.12	
Ø04	.17	.17
Ø05	.23	
Ø06	.30	.26
Ø08	.39	.38
Ø10	.48	.48
Ø12	.61	.61
Ø16	.84	.81
Ø20	1.08	1.05
Ø24	1.31	1.31
Ø32	1.78	

# Technical Data

## How to Identify Fluid Connectors

### How to Measure Non-threaded connections

**Four Bolt Flange**—First measure the port hole diameter using the caliper. Next, measure the longest bolt hole spacing from center-to-center or measure the flange head diameter.

**Staplok®**—Measure the male diameter with the O.D. portion of the caliper. Measure the female half by inserting the I.D. portion of the caliper into the through hole.

### Dash Numbers

Most fluid piping system sizes in the United States are measured by dash numbers. These are universally used abbreviations for the size of the component expressed as the numerator of the fraction with the denominator always being 16. For example, a -04 port is  $\frac{4}{16}$  or  $\frac{1}{4}$ -inch. Dash numbers are usually nominal (in name only) and are abbreviations that make ordering of components easier.

### American connections NPTF (National Pipe Tapered Fuel)

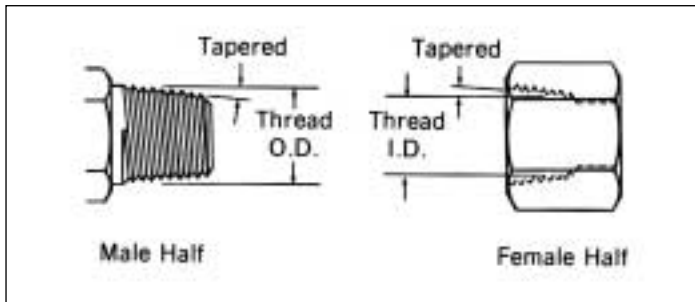

This connection is still widely used in fluid power systems, even though it is not recommended by the National Fluid Power Association (NFPA) for use in hydraulic applications. The thread is tapered and the seal takes place by deformation of the threads.

#### NPTF Threads

Measure thread diameter and subtract  $\frac{1}{4}$ -inch to find the nominal pipe size.

INCH SIZE	DASH SIZE	NOMINAL THREAD SIZE	MALE THREAD O.D. (INCH)		FEMALE THREAD I.D. (INCH)	
			FRACTION	DECIMAL	FRACTION	DECIMAL
$\frac{1}{8}$	02	$\frac{1}{8}$ -27	$\frac{13}{32}$	.41	$\frac{3}{8}$	.38
$\frac{1}{4}$	04	$\frac{1}{4}$ -18	$\frac{17}{32}$	.54	$\frac{1}{2}$	.49
$\frac{3}{8}$	06	$\frac{3}{8}$ -18	$\frac{11}{16}$	.68	$\frac{5}{8}$	.63
$\frac{1}{2}$	08	$\frac{1}{2}$ -14	$\frac{27}{32}$	.84	$\frac{25}{32}$	.77
$\frac{3}{4}$	12	$\frac{3}{4}$ -14	$\frac{11}{16}$	1.05	1	.98
1	16	1-1 $\frac{1}{2}$	$\frac{15}{16}$	1.32	$\frac{1}{4}$	1.24
1 $\frac{1}{4}$	20	1 $\frac{1}{4}$ -11 $\frac{1}{2}$	$\frac{121}{32}$	1.66	$\frac{11}{32}$	1.58
1 $\frac{1}{2}$	24	1 $\frac{1}{2}$ -11 $\frac{1}{2}$	$\frac{129}{32}$	1.90	$\frac{11}{16}$	1.82
2	32	2-1 $\frac{1}{2}$	$\frac{25}{8}$	2.38	$\frac{2}{16}$	2.30

### American connections NPSM (National Pipe Straight Mechanical)

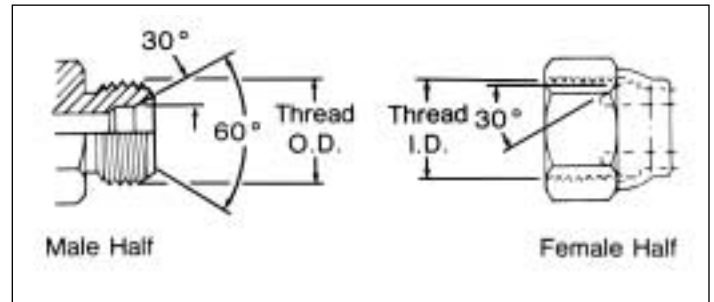

This connection is sometimes used in fluid power systems. The female half has a straight thread and an inverted 30° seat. The male half of the connection has a straight thread and a 30° internal chamfer. The seal takes place by compression of the 30° seat on the chamfer. The threads hold the connection mechanically.

**NOTE:** A properly chamfered NPTF male will also seal with the NPSM female.

INCH SIZE	DASH SIZE	NOMINAL THREAD SIZE	MALE THREAD O.D. (INCH)		FEMALE THREAD I.D. (INCH)	
			FRACTION	DECIMAL	FRACTION	DECIMAL
$\frac{1}{8}$	02	$\frac{1}{8}$ -27	$\frac{13}{32}$	.41	$\frac{3}{8}$	.38
$\frac{1}{4}$	04	$\frac{1}{4}$ -18	$\frac{17}{32}$	.54	$\frac{1}{2}$	.49
$\frac{3}{8}$	06	$\frac{3}{8}$ -18	$\frac{11}{16}$	.68	$\frac{5}{8}$	.63
$\frac{1}{2}$	08	$\frac{1}{2}$ -14	$\frac{27}{32}$	.84	$\frac{25}{32}$	.77
$\frac{3}{4}$	12	$\frac{3}{4}$ -14	$\frac{11}{16}$	1.05	1	.98
1	16	1-1 $\frac{1}{2}$	$\frac{15}{16}$	1.32	$\frac{1}{4}$	1.24
1 $\frac{1}{4}$	20	1 $\frac{1}{4}$ -11 $\frac{1}{2}$	$\frac{121}{32}$	1.66	$\frac{11}{32}$	1.58
1 $\frac{1}{2}$	24	1 $\frac{1}{2}$ -11 $\frac{1}{2}$	$\frac{129}{32}$	1.90	$\frac{11}{16}$	1.82
2	32	2-1 $\frac{1}{2}$	$\frac{25}{8}$	2.38	$\frac{2}{16}$	2.30

# Technical Data

## How to Identify Fluid Connectors

### American connections

#### SAE J1926 Straight Thread O-Ring Boss (ORB)

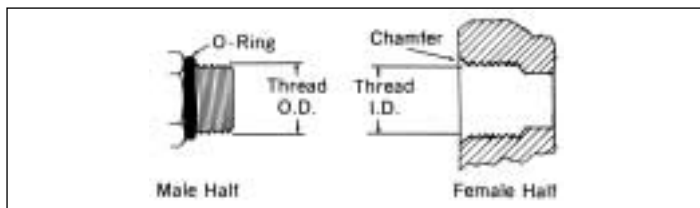

This port connection is recommended by the NFPA for optimum leakage control in medium and high pressure hydraulic systems. The male connector has a straight thread and an O-Ring. The female port has a straight thread, a machined surface (minimum spotface) and a chamfer to accept the O-Ring. The seal takes place by compressing the O-Ring into the chamfer. The threads hold the connection mechanically.

INCH SIZE	DASH SIZE	NOMINAL THREAD SIZE	MALE THREAD O.D. (INCH)		FEMALE THREAD I.D. (INCH)	
			FRACTION	DECIMAL	FRACTION	DECIMAL
1/8	02	5/16-24	5/16	.31	9/32	.27
3/16	03	3/8-24	3/8	.38	11/32	.34
1/2	04	7/16-20	7/16	.44	13/32	.39
5/16	05	1/2-20	1/2	.50	15/32	.45
3/8	06	9/16-18	9/16	.56	17/32	.51
1/2	08	3/4-16	3/4	.75	3/4	.69
5/8	10	7/8-14	7/8	.88	13/16	.81
3/4	12	1 1/16-12	1 1/16	1.06	1	.98
7/8	14	1 1/16-12	1 3/16	1.19	7/8	1.13
1	16	1 1/8-12	1 5/16	1.31	7/4	1.23
1 1/4	20	1 1/8-12	1 7/8	1.63	7/16	1.54
1 1/2	24	1 1/8-12	1 7/8	1.88	7/16	1.79
2	32	2 -12	2 1/2	2.50	2 1/16	2.42

### American connections

#### SAE J514i\* 37 Hydraulic

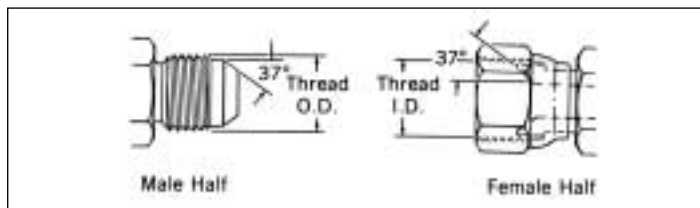

This connection is very common in fluid power systems. Both the male and female halves of the connections have 37° seats. The seal takes place by establishing a line contact between the male flare and the female cone seat. The threads hold the connection mechanically.

**CAUTION:** In the  $\text{D}02$ ,  $\text{D}03$ ,  $\text{D}04$ ,  $\text{D}05$ ,  $\text{D}08$  and  $\text{D}10$  sizes, the threads of the SAE 45i flare and the SAE 37i flare are the same. However, the sealing surface angles are not the same.

INCH SIZE	DASH SIZE	NOMINAL THREAD SIZE	MALE THREAD O.D. (INCH)		FEMALE THREAD I.D. (INCH)	
			FRACTION	DECIMAL	FRACTION	DECIMAL
1/8	02	5/16-24	5/16	.31	9/32	.27
3/16	03	3/8-24	3/8	.38	11/32	.34
1/4	04	7/16-20	7/16	.44	13/32	.39
5/16	05	1/2-20	1/2	.50	15/32	.45
3/8	06	5/8-18	5/8	.63	9/16	.57
1/2	08	3/4-16	3/4	.75	7/16	.69
5/8	10	7/8-14	7/8	.88	13/16	.81
3/4	12	1 1/16-14	1 1/16	1.06	1	.99
7/8	14	1 1/4-12	1 1/4	1.25	7/32	1.16
1	16	1 1/8-12	1 7/8	1.38	7/32	1.29

# Technical Data

## Thread Engagement Dimensions

### Thread engagement dimensions—Nominal

Dimensions may vary due to tolerance conditions.

Listed below are the thread engagement dimensions (B) which must be taken into consideration when making connections with ports or appropriate female adapters.

The "B" dimension must be subtracted from the overall length (a) to insure proper connection.

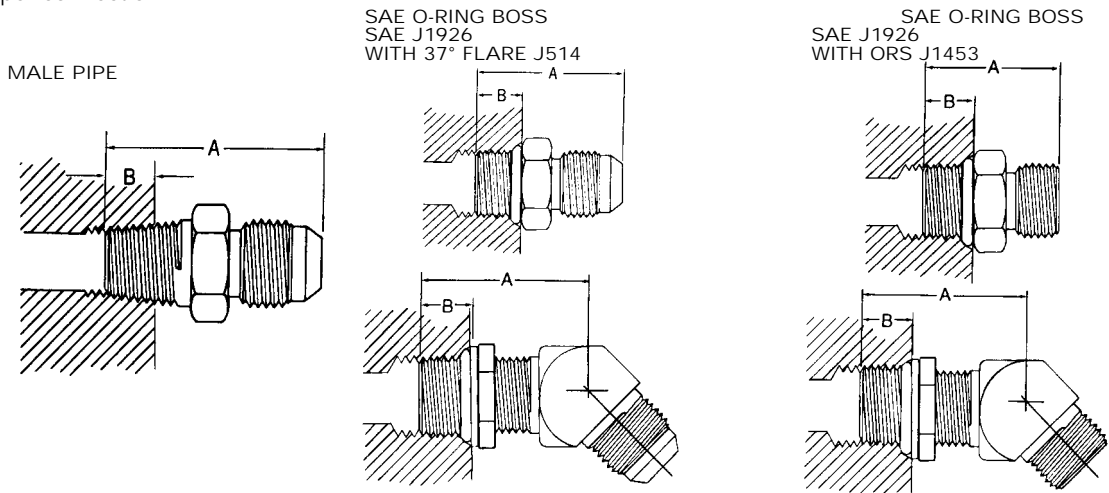

DASH SIZE	STRAIGHT AND ANGLED DIMENSION "B"	STRAIGHT AND ADJUSTABLE DIMENSION "B"	STRAIGHT AND ADJUSTABLE DIMENSION "B"
Ø02	.25		
Ø04	.38	.36	.43
Ø05		.36	.43
Ø06	.38	.39	.47
Ø08	.50	.43	.55
Ø10		.50	.63
Ø12	.62	.59	.73
Ø14		.59	
Ø16	.69	.59	.73
Ø20	.69	.59	.73
Ø24	.69	.59	.73
Ø32	.75	.59	

### Allowable bulkhead thickness For ORS:

DASH SIZE	HOLE DIAMETER	ORS BULKHEAD THICKNESS MIN	MAX
Ø04	.575 +.015/Ø.000	.195	.500
Ø06	.700 +.015/Ø.000	.200	.590
Ø08	.825 +.015/Ø.000	.220	.590
Ø10	1.015 +.015/Ø.000	.230	.590
Ø12	1.200 +.015/Ø.000	.245	.590
Ø16	1.450 +.015/Ø.000	.245	.600
Ø20	1.715 +.015/Ø.000	.245	.600
Ø24	2.030 +.015/Ø.000	.245	.600

### For 37<sub>i</sub> Flare:

DASH SIZE	HOLE DIAMETER	37° BULKHEAD THICKNESS STRAIGHTS MIN	MAX	SHAPES MIN	MAX
Ø03	.391 +.016/Ø.000	.047	.406	.125	.250
Ø04	.453 +.016/Ø.000	.047	.406	.125	.281
Ø05	.516 +.016/Ø.000	.047	.406	.125	.281
Ø06	.578 +.016/Ø.000	.047	.438	.125	.297
Ø08	.766 +.016/Ø.000	.047	.438	.156	.344
Ø10	.891 +.016/Ø.000	.047	.469	.156	.359
Ø12	1.076 +.016/Ø.000	.047	.469	.156	.375
Ø16	1.328 +.016/Ø.000	.047	.469	.156	.375
Ø20	1.656 +.031/Ø.000	.047	.469	.156	.375
Ø24	1.906 +.031/Ø.000	.047	.469	.156	.375

All dimensions in inches. Dimensions may vary due to tolerance conditions.

# Technical Data

## Assembly Torque

### Recommended parallel connection assembly torque

Eaton recommends that a torque wrench be used to assure proper fitting assembly of these connections.

#### STRAIGHT THREAD O-RING BOSS LOW PRESSURE WITH 37° (SAEJ514)

DASH SIZE METERS	THREAD SIZE (INCHES)	JAM NUT OR STRAIGHT FITTING TORQUE FT./LBS.	NEWTON
Ø03	3/8-24	8-9	12-13
Ø04	7/16-20	13-15	18-20
Ø05	1/2-20	14-15	19-21
Ø06	9/16-18	23-24	32-33
Ø08	3/4-16	40-43	55-57
Ø10	7/8-14	43-48	59-64
Ø12	1 1/16-12	68-75	93-101
Ø14	1 1/8-12	83-90	113-122
Ø16	1 1/4-12	112-123	152-166
Ø20	1 3/8-12	146-161	198-218
Ø24	1 7/8-12	154-170	209-230
Ø32	2-12	218-240	296-325

### Recommended parallel connection assembly torque

#### SAE 37° (JIC)

DASH SIZE	THREAD SIZE (INCHES)	SWIVEL NUT TORQUE FT./LBS.	NEWTON METERS
Ø04	7/16-20	11-12	15-16
Ø05	1/2-20	15-16	20-22
Ø06	9/16-18	18-20	24-28
Ø08	3/4-16	38-42	52-58
Ø10	7/8-14	57-62	77-85
Ø12	1 1/16-12	79-87	108-119
Ø16	1 1/8-12	108-113	148-154
Ø20	1 3/8-12	127-133	173-182
Ø24	1 7/8-12	158-167	216-227
Ø32	2-12	245-258	334-352

# Technical Data

## Tube Installation

### Proper tube installation

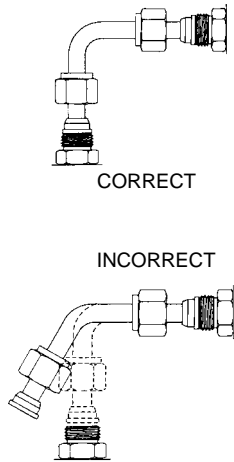

fig. 1

When compared to rigid pipe, hydraulic tubing offers the following advantages:

1. Size for size, tubing is lighter in weight, easier to handle and can be bent more easily than iron pipe.
2. Bent tubing reduces pressure drop and turbulence in the system because it eliminates sudden change in the direction of the fluid flow.
3. Hydraulic tubing reduces the number of connections required, thus reducing material and labor costs.
4. Fewer joints means lower costs and fewer points of potential leakage.
5. The use of tube fittings makes every joint a union which permits easier, faster maintenance and repair work.
6. The Eaton Aeroquip ORS-TF Tube Fitting eliminates the need for threading, brazing or welding.

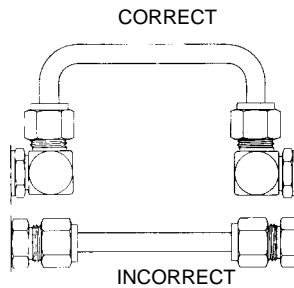

fig. 2

### Tube bending

To reduce the number of fittings in a tube assembly, bend the tubing whenever possible.

Steel tubing can be bent in many sizes by using a hand bender designed for steel tubing. For production quantities, or for larger sizes, a power bending tool is generally used. Contact Eaton for additional tube bending information.

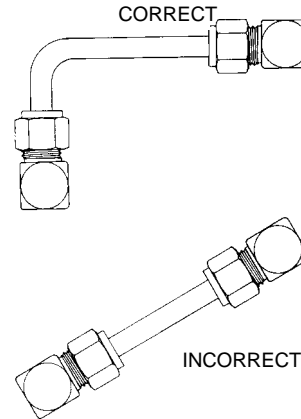

fig. 3

### Tube routing and installation

Tubing manufacturers will advise the correct radii for various types and wall thicknesses of tubing. Kinks, flattened bends, wrinkles and tube breakage can be avoided by the use of proper tube bending equipment.

Avoid straight line connections whenever possible, especially in short runs.

Fluid conveying systems (see figures 2, 3 and 4) should be designed to follow the contour of the equipment. They are easier to install and present a neater appearance. Long runs should be supported by brackets or clamps. All heavy systems components should be bolted or clamped to eliminate tubing fatigue.

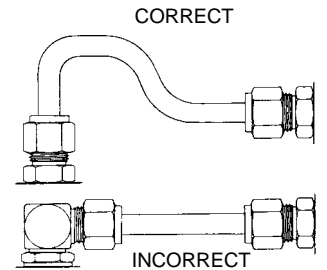

fig. 4

Inspect the tubing to see that it conforms to the required specifications before installation.

Tubes should align with the center line of the fittings, without distortion or tension. Tubing should not be sprung into position (see figure 1) to be assembled to the fitting. If this occurs the tubing has not been properly fabricated, and when installed and connected, places the tubing under stress.

# Technical Data

## Bend/Flexing Graphs

### Bend Radius vs. Operating Pressure

The charts below show graphically the variation in operating pressure when hose is subjected to various degrees of bend. When hose is subjected to bends smaller than recommended, hose operating pressure limits are reduced. Likewise, if hose is subjected to lower operating pressures a small bend radius may be used.

NOTE: Minimum bend radius is measured at inside of bend.

### Single Wire Braid Hose bend radius with no flexing AE369, AE372

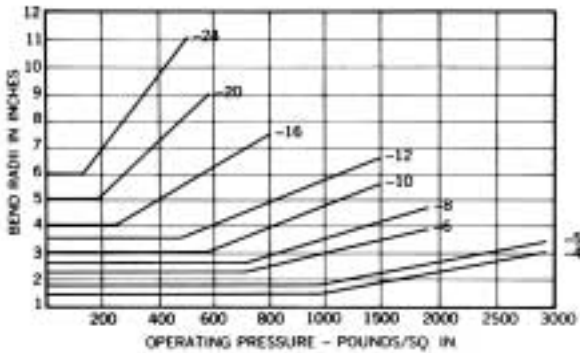

NOTE: Minimum bend radii for larger sizes at all pressure are as follows  
 -32 = 13 1/4 inches  
 -40 = 24 inches  
 -48 = 33 inches

### Double Wire Braid Hose bend radius with no flexing AE371, AE373, FC163

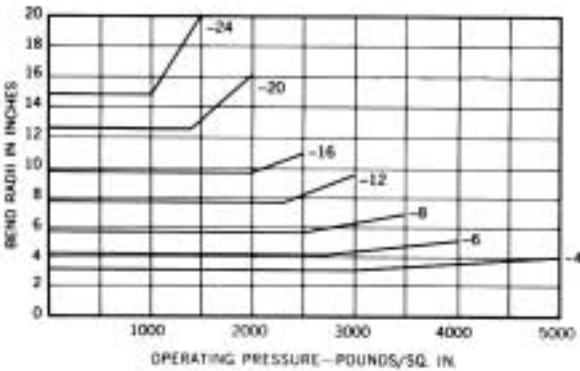

### Spiral Wrap Hose bend radius with no flexing AE374, FC162

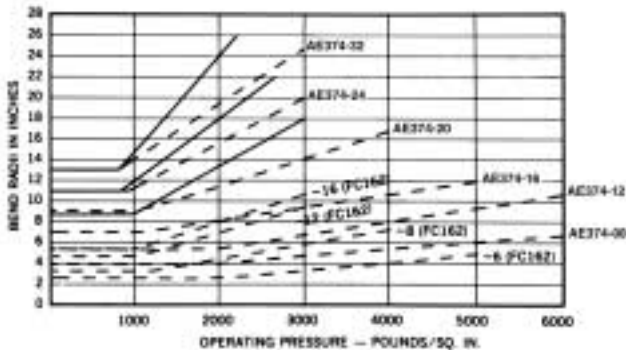

### Flexing

Minimum bend radius under flexing conditions = Bend factor "N" x Bend radius of the hose with no flexing

EXAMPLE: For AE369 Hose, -12 size at 1500 psi and with flexing range of 60°:

Minimum bend radius = 1.16 x 6.5 = 7 1/2 inches (measured at inside of bend).

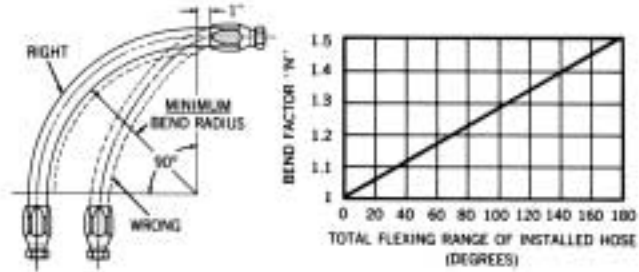

Free lengths of hose required for deflections of 10" or less  
 150901, AE37, AE373, FC163

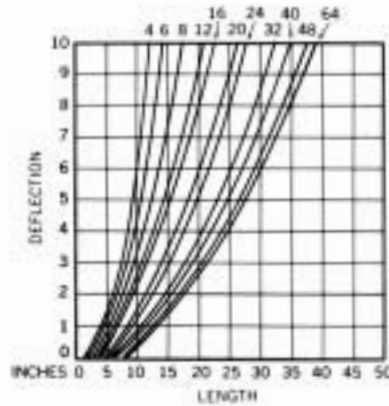

AE369, AE370, AE372, FC234

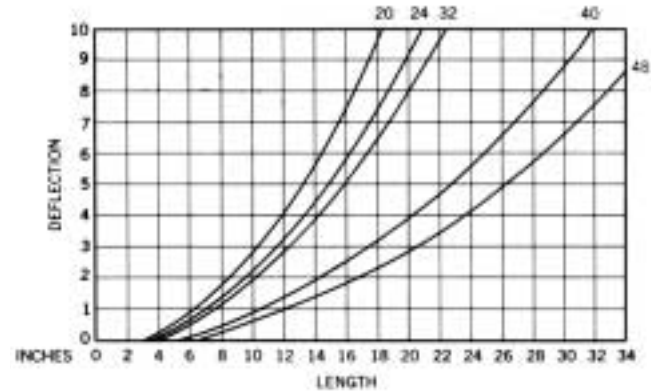

Example:  
 2" deflection of FC163-20 Hose requires 111 1/4" free length of hose

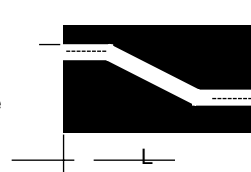

Example:  
 1" deflection of AE369-20 Hose requires 6" free length of hose

# Technical Data

## Conversion Tables

MULTIPLY	BY	TO OBTAIN
Atmospheres	14.70	Lbs./sq. inch
Atmospheres	1.013	Bars
Bars	0.9869	Atmospheres
Centimeters	0.3937	Inches
Feet	0.3048	Meters
Gallons	231	Cubic inches
Gallons, Imperial	1.20095	U.S. gallons
Gallons, U.S.	0.83267	Imperial gallons
Gallons, Water	8.3453	Pounds of water
Gallons/min	8.0208	Cu. ft./hr.
Horse-power	745.7	Watts
Inches of mercury	1.133	Feet of water
Kilometers	0.6214	Miles
Liters	0.03531	Cubic feet
Liters	61.02	Cubic inches
Liters	0.2642	Gallons
Meters	3.281	Feet
Meters	29.37	Inches
Microns	10 <sup>6</sup>	Meters
Miles	5280	Feet
Miles	1.609	Kilometers
Miles/hr	1.609	Kilometers/hr
Miles/hr	0.8684	Knots
Ounces	0.0625	Pounds
Ounces	28.349527	Grams
Ounces (fluid)	1.805	Cubic inches
Ounces (fluid)	0.02957	Liters
Pounds	453.5924	Grams
Pounds of water	0.1198	Gallons
Pounds/sq. inch	0.06804	Atmospheres
Temp. °C)	1.8	+32 Temp.°F)
Temp. °F)	5/9	Temp.°C)

Hydraulic (fluid power) horsepower:

$$HP = \text{PSI} \times \text{GPM} \div 1714$$

PSI is gauge pressure in pounds per square inch, GPM is oil flow in gallons per minute.

Thrust or force of any cylinder:

$$T = A \times \text{PSI}$$

T is thrust or force, in pounds.

A is piston net area in square inches.

PSI is gauge pressure.

$$S = V \div A$$

S = Travel speed, inches/minute

INCH/MILLIMETER CONVERSION TABLE

INCHES FRACTIONS	DECIMALS	MILLIMETERS DECIMALS
$\frac{1}{16}$	.016	.397
$\frac{1}{8}$	.031	.794
$\frac{3}{16}$	.047	1.191
$\frac{1}{4}$	.063	1.588
$\frac{5}{16}$	.078	1.984
$\frac{3}{8}$	.094	2.381
$\frac{7}{16}$	.109	2.778
$\frac{1}{2}$	.125	3.175
$\frac{9}{16}$	.141	3.572
$\frac{5}{8}$	.156	3.969
$\frac{11}{16}$	.172	4.366
$\frac{3}{4}$	.188	4.763
$\frac{13}{16}$	.203	5.159
$\frac{7}{8}$	.219	5.556
$\frac{15}{16}$	.234	5.953
$1\frac{1}{16}$	.250	6.350
$1\frac{1}{8}$	.266	6.747
$1\frac{1}{4}$	.281	7.144
$1\frac{3}{8}$	.297	7.541
$1\frac{5}{8}$	.313	7.938
$1\frac{3}{4}$	.328	8.334
$1\frac{7}{8}$	.344	8.731
$2\frac{1}{8}$	.359	9.128
$2\frac{1}{4}$	.375	9.525
$2\frac{3}{8}$	.391	9.922
$2\frac{1}{2}$	.406	10.319

### Computing Piston Area

The area of a piston or ram can be computed by this formula:

$$A = \frac{p \times d^2}{4}$$

A is area (square inches or square centimeters)

d is diameter of piston (inches or centimeters)

p/4 is 0.7854

These pressure, force and area relationships are sometimes illustrated as shown below to aid in remembering the equations.

$$F = P \times A$$

$$P = F/A$$

$$A = F/P$$

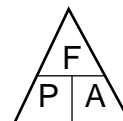

Eaton  
14615 Lone Oak Road  
Eden Prairie, MN 55344  
USA  
Tel: 952 937-9800  
Fax: 952 974-7722  
[www.hydraulics.eaton.com](http://www.hydraulics.eaton.com)

Eaton  
20 Rosamond Road  
Footscray  
Victoria 3011  
Australia  
Tel: (61) 3 9319 8222  
Fax: (61) 3 9318 5714

Eaton  
Dr.-Reckeweg-Str. 1  
D-76532 Baden-Baden  
Germany  
Tel: (49) 7221 682-0  
Fax: (49) 7221 682-788