



7270 & 7271 Series Circuit Breakers

Miniature Aircraft

Features

- Trip free
- Snap-acting thermal element
- Simplicity of design
- High rupture capacity – 3500 amps, 120 VAC, 400 Hz, 4000 amps, 30VDC
- Light weight
- Small size

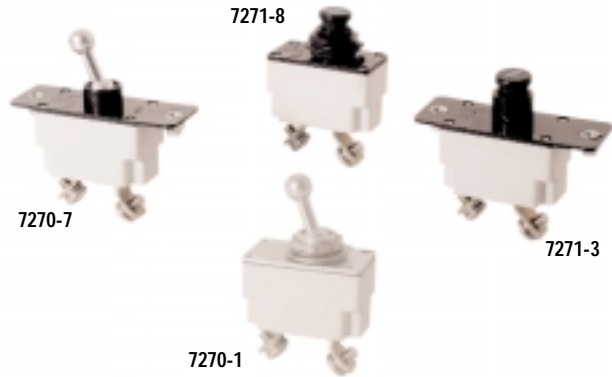

Overview

The Klixon 7270/7271 series circuit breakers were designed to utilize less space behind the panel space while protecting wire and cable in aircraft and ground support equipment on either 120 VAC, 400 Hz or 30 VDC systems. The units are available with neck mounting (7270-1 and 7271-8) or standard cover plate (7270-7 and 7271-3). In each of these Klixon circuit breakers, the bi-metallic element assures uniform current distribution throughout its responsive area. This design reduces current density at the critical areas, resulting in an element having a much higher interrupting capability than conventional design. Inherently resistant to shock and vibration, the Klixon disc element is capable of precise calibration settings and will retain the initial calibration within close tolerances throughout the service life of the breaker. Both circuit breakers have conventional actuator action; i.e., the toggle actuator on the 7270 moves to the OFF position for trip indication and the button of the 7271 pops out. A standard black button with a white collar is used.

Qualifications

TI Number	MS Number	TI Number	MS Number	TI Number	MS Number
7270-1-3	N/A	7270-7-10	MS 24509-B-10	7271-3-25	N/A
7270-1-5	MS 24509-A-5	7270-7-15	MS 24509-B-15	7271-3-30	N/A
7270-1-7½	MS 24509-A-7½	7270-7-20	N/A	7271-3-35	N/A
7270-1-10	MS 24509-A-10	7270-7-25	N/A	7271-8-3	N/A
7270-1-15	MS 24509-A-15	7270-7-30	N/A	7271-8-5	MS 24510-A-5
7270-1-20	N/A	7270-7-35	N/A	7271-8-7½	MS 24510-A-7½
7270-1-25	N/A	7271-3-3	N/A	7271-8-10	MS 24510 A-10
7270-1-30	N/A	7271-3-5	MS 24510-B-5	7271-8-15	MS 24510-A-15
7270-1-35	N/A	7271-3-7½	MS 24510-B-7½	7271-8-20	N/A
7270-7-3	N/A	7271-3-10	MS 24510-B-10	7271-8-25	N/A
7270-7-5	MS 24509-B-5	7271-3-15	MS 24510-B-15	7271-8-30	N/A
7270-7-7½	MS 24509-B-7½	7271-3-20	N/A	7271-8-35	N/A

Optional Covers

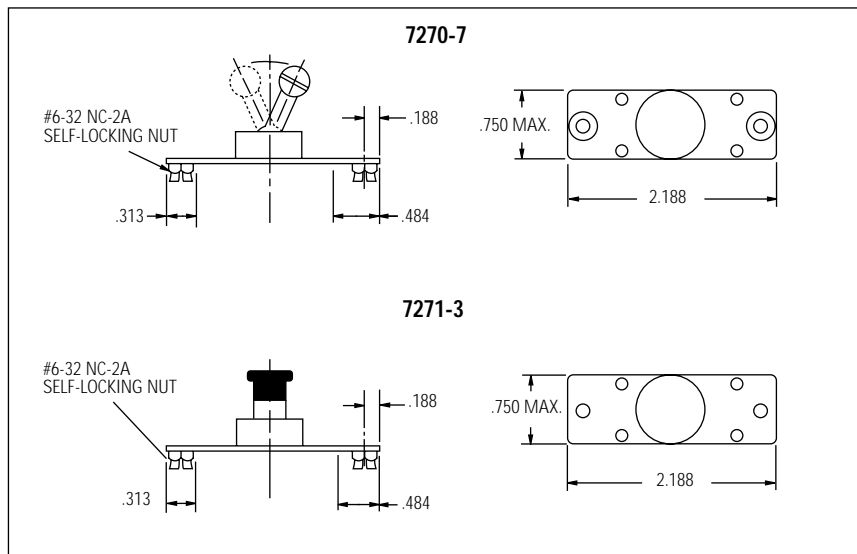

Characteristics

7270/7271

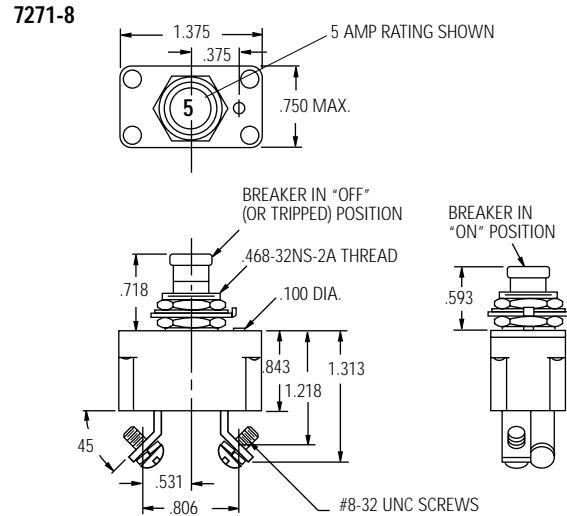
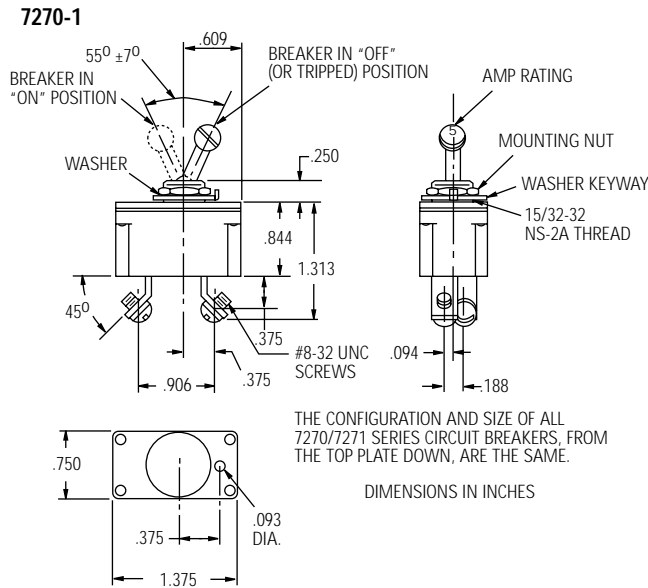

Calibration: 3-35 amps

Temp °C	Min ULT Trip	Max ULT Trip	Rating	Trip Time - Seconds		
				200%	400%	600%
+25	115%	145%	3 amps	40-120	3-26	1-12
			5 amps	40-100	3-22	1-10
			71/2-35	10-70	.75-7.0	.25-2.5
-40	138%	175%	-	-	-	-
+71	80%	125%	-	-	-	-

Vibration* 10 G's minimum, 50-500 Hz
 Mechanical Shock 30 G's
 Acceleration 10 G's
 Weight 7270-1 - 39 gm max.
 7271-8 - 39 gm max.

Interrupt Current

4000 amps, 30 VDC
 3500 amps, 120 VAC, 400 Hz

Endurance

200 cycles 30 VDC Inductive
 5000 cycles 120 VAC, 400 Hz Inductive
 5000 cycles 120 VAC, 400 Hz Resistive
 5000 cycles 30 VAC, 400 Hz Resistive
 10,000 cycles Mechanical, no load

TI Number 7270's	TI Number 7271's	Voltage Drop (Max.)**
7270-x-3	7270-x-3	0.75
7270-x-5	7270-x-5	0.65
7270-x-7½	7270-x-7½	0.5
7270-x-10	7270-x-10	0.5
7270-x-15	7270-x-15	0.5
7270-x-20	7270-x-20	0.5
7270-x-25	7270-x-25	0.5
7270-x-30	7270-x-30	0.5
7270-x-35	7270-x-35	0.5

**Max voltage drop at nominal rated current.

* Other vibration levels available. Contact factory for details.

Approximate Time-Current Curves 7270 and 7271 Circuit Breakers

