

# STANLEY®

Engineered Fastening



## Fastening Systems Product Overview



# Speed Fastening® Systems

## Benefits of assembly

POP Avdel Speed Fastening systems provide rapid and reliable assembly of metals, plastics, composites and passive electronic components. The fasteners are either magazine-fed or fed via a vibrating bowl to a wide choice of installation equipment. At the end of each assembly cycle, the next fastener is automatically delivered to the nose of the tool ready to repeat the assembly process. Speed Fastening offers many benefits over conventional mechanical assembly systems, including:

- High speed, blind sided assembly
- Consistent clamp and grip
- Good vibration resistance
- Highly controlled assembly
- Short cycle times
- Elimination of over-torquing

## Typical placing sequence

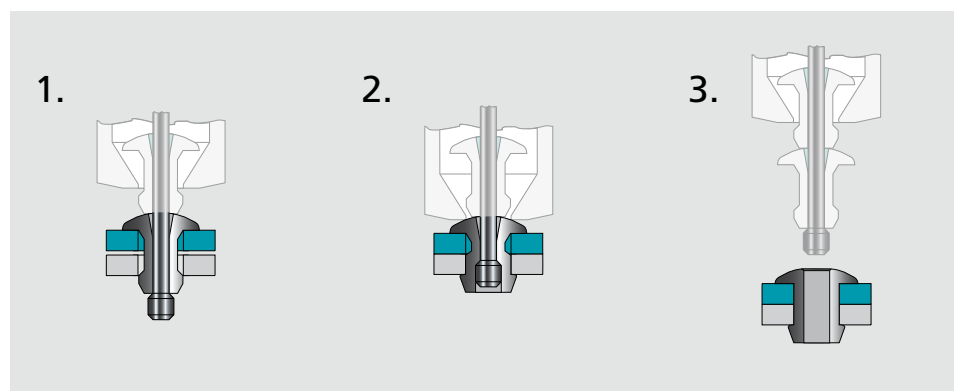

1. The mandrel with pre-loaded fastener is located in the hole.

2. Tool activation pulls the mandrel through the fastener, expanding it within the hole to provide high clamp and secure joints.

3. At the end of the installation cycle, the next fastener is automatically delivered to the nose of the tool, ready to repeat the assembly process.

Please visit our website [StanleyEngineeredFastening.com](http://StanleyEngineeredFastening.com) for fastener placing animations.

## Assembly applications

- Aluminium die-cast boxes
- Car bumpers and doors
- DIN connectors and heatsinks to PCB's
- Domestic appliances
- Electrical engineering
- Lighting equipment
- PCB's to chassis assemblies
- Switchgear
- Telecommunications equipment

Window hinge



Gas firing

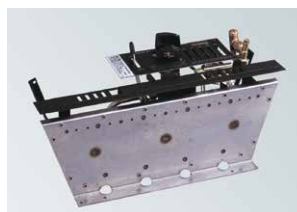

Computer chassis



Composite material latch for wheel cover



Vacuum pump for diesel engines







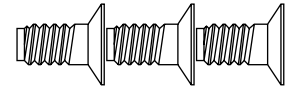



Automotive die-cast chassis with PCB





## Range Overview

NeoSpeed®		Wide grip range High joint clamp Hole filling Very high strength	Grovit®		Designed for blind hole applications Annular grooves on body For use in wood, plastics fibreglass and aluminium
Briv®		Bulbed tail form Large headform High joint clamp Good joint gap closure	Avtronic®		Attaches DIN 41612 connectors and other components to PCBs Annular grooves on body
Rivscrew®		Threaded fastener Removable with hex key and reusable Fastens into materials up to Vickers hardness 105 Hv5	Avsert®		Threaded stand-off pillars for PCBs Internally threaded bore Many stand-off heights
Chobert®		Internal tapered bore Controlled clamp High shear Ideal for soft and brittle materials	Avlug®		Solderable terminal posts for PCBs Rolled/knurled shank
Double Flush Chobert®		Flush surface on both sides of the joint Reduces excess space requirements within the chassis			

## Installation Equipment

7537



753



7535 Pantograph workstation



Mini-MAS



23 placing heads to assemble a computer chassis



70510 Underbench workstation



Twin head fixed pitch workstation

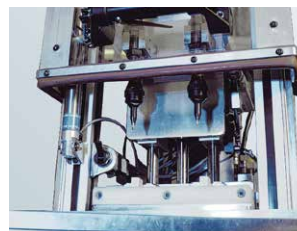

Customised systems

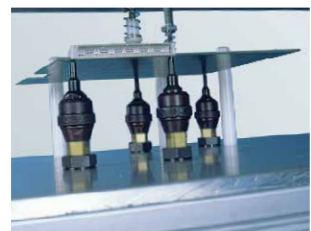

# Breakstem Riveting Systems

## Benefits of assembly

POP Avdel breakstem fasteners and installation tools are a premier fastening system offering multi-grip performance, consistent and reliable installation and high speed, high performance assembly. Used in all manufacturing industries throughout the world, there is an POP Avdel breakstem fastener and installation tool to suit virtually every assembly requirement. Key user benefits include:

- Blind sided assembly
- Multi-grip performance
- Complete hole fill
- High speed assembly
- Good clamp and vibration resistance
- Consistent high performance
- Positive stem retention
- Extensive product choice

## Typical placing sequence

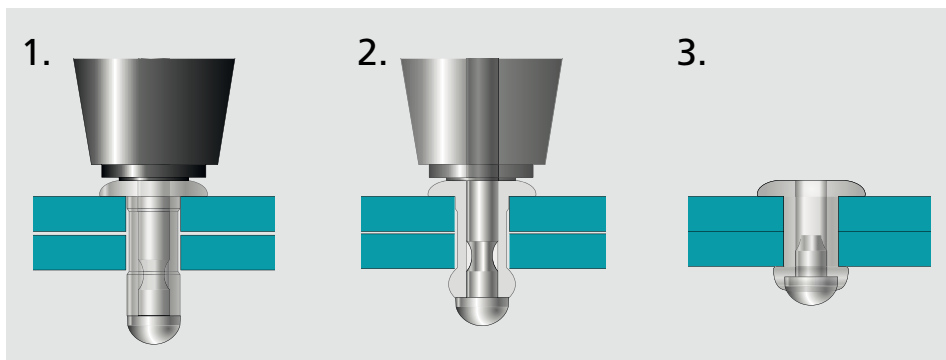

1. The fastener is located on the tool nose piece and inserted into the prepared hole in the workpiece.

2. On activating the tool, the fastener pulls the materials together and expands to fill the hole.

3. At a pre-determined load, the fastener stem breaks flush with the fastener head, leaving a locked stem.

Please visit our website [StanleyEngineeredFastening.com](http://StanleyEngineeredFastening.com) for fastener placing animations.

## Assembly applications

- Automotive components
- Boats and caravans
- Building and construction
- Cabinets and enclosures
- Commercial vehicles
- Domestic appliances
- Electrical components
- Garage doors
- Heating and ventilation
- Railway rolling stock
- Reefer cool containers
- Storage and warehousing

Domestic heating systems



Passenger air bag



Sliding luggage cover



Garage doors



Wood application







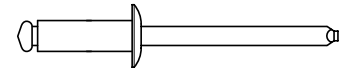

Telecommunications cabinets



# non-structural



## Range Overview

<p><b>Open End Rivets</b></p> 	<p>Cost effective standard rivet Installed quickly and easily Design of the stem head ensures positive retention after installation</p>	<p><b>Avibulb® / Avinox®</b></p> 	<p>High shear and tensile strength Retained stem Large blind side bearing area Stainless steel Avinox for high corrosion resistance</p>
<p><b>Soft Set</b></p> 	<p>Designed for soft or brittle materials Incorporates a special aluminum alloy Low clamping force</p>	<p><b>Bulbex®</b></p> 	<p>Split tail formation for thin sheet &amp; low strength materials Multi-grip capability Retained stem</p>
<p><b>Micro Rivet</b></p> 	<p>Smallest blind rivet available accommodates very small holes Very low secondary side clearance Soft set body will not damage work piece Ideal for thin metal and PCBs</p>	<p><b>Klamp-Tite® (non-structural)</b></p> 	<p>Split tail formation for thin sheet &amp; low strength materials Multi-grip capability Good clamp up</p>
<p><b>Pull-Thru (PT)</b></p> 	<p>Flush set on both sides of the application Insertion can be reversed improving rivet tool access No loose stem heads remain in the application Tight radial set provides increased structural rigidity</p>	<p><b>T-Lok®</b></p> 	<p>'Peel-type' tail formation for joining wood to metal Wide grip range Retained stem</p>
<p><b>Closed End Rivets</b></p> 	<p>Seals out moisture, air and other contaminants Higher tensile and shear strength than the equivalent open end rivet 100% stem retention</p>	<p><b>Avdelmate®</b></p> 	<p>Two piece fastener Extra wide grip range Large bearing area against both sides of the application Excellent hole fill</p>
<p><b>Avex®</b></p> 	<p>Multi-grip capability Good hole fill Retained stem Large blind side bearing area</p>	<p><b>Earth Tab Rivet</b></p> 	<p>Cost effective earthing point Paint piercing capability Twin tabs allow one or two connections</p>
<p><b>Stavex®</b></p> 	<p>Multi-grip capability Good hole fill Retained stem Large blind side bearing area</p>	<p><b>Avex® Splined</b></p> 	<p>Steel splines for electrical continuity in earthing applications Multi-grip capability</p>

## Installation Equipment

PB2500 battery tool



ProSet® XT1 - coming soon



ProSet® XT2 - coming soon



Genesis® nG2-S



# Breakstem Riveting Systems

## Benefits of assembly

POP Avdel structural breakstem systems are designed for rapid, blind sided assembly in load-bearing structural applications, where high shear and tensile strength is required. Key user benefits include:

- Blind sided assembly
- High shear and tensile strength
- Multi-grip performance
- Complete hole fill
- High speed assembly
- Good clamp and vibration resistance
- Consistent high performance
- Positive stem retention
- Extensive product choice

## Typical placing sequence

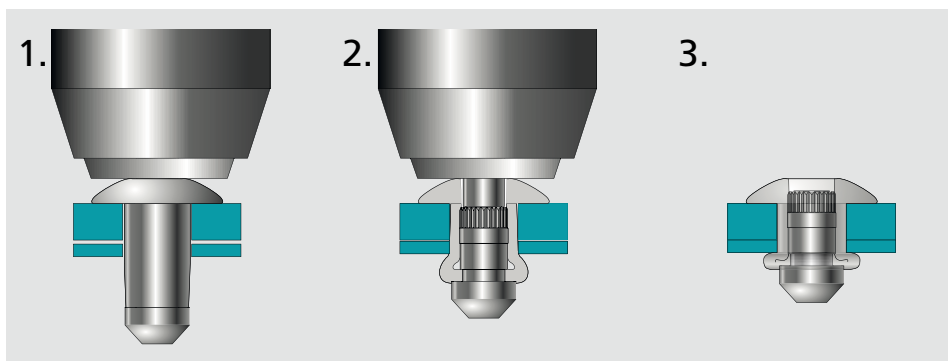

1. The fastener is located on the tool nose piece and inserted into the prepared hole in the workpiece.

2. On activating the tool, the fastener pulls the materials together and expands to fill the hole.

3. At a pre-determined load, the fastener stem breaks flush with the fastener head, leaving a locked stem.

Please visit our website [StanleyEngineeredFastening.com](http://StanleyEngineeredFastening.com) for fastener placing animations.

## Assembly applications

- Agricultural equipment
- Automotive assemblies and components
- Boats and caravans
- Building and construction
- Cabinets and enclosures
- Commercial vehicle bodies
- Domestic appliances
- Heating and ventilation
- Pallets and racking
- Roofing and cladding
- Railway rolling stock
- Reefer cool and dry freight containers

Product cooler



Column tail lifts



Car seat base



Step ladder



Vehicle panel



Heat exchanger



# structural

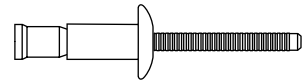

## Range Overview

Avibulb® XT & Avinox® XT



Multi-grip capacity  
High residual clamp load  
Good blind side footprint and bulb formation  
Avibulb® XT = steel  
Avinox® XT = stainless steel

Hemlok®



Very high shear & tensile strength  
Large blind side bearing area  
Interference lock via splined stem

Monobolt®



Multi-grip capability  
Fully sealed fastener  
Visible lock  
Excellent hole fill  
Mechanically locked stem  
Good sheet take-up performance

Interlock®



Multi-grip capability  
Fully sealed fastener  
Excellent hole fill  
Mechanically locked stem  
Good sheet take-up performance

Q Rivet



Interference lock via a splined stem  
Stem plugs entire shell length  
Weatherproof

Klamp-Tite® (structural)



Split tail formation for thin sheet and low strength materials  
Multi-grip capability  
Good clamp up  
Mechanically locked stem  
Visible lock

T Rivet



'Peel-type' tail formation  
High shear and tensile strength  
High clamp up  
Visible lock

## Lockbolt for blind sided assembly

Avbolt®



Use on blind sided application  
High residual clamp force  
High tensile and shear strength  
Speed of installation  
Vibration resistance  
High grip capability

## Avseal® Sealing Plug

Avseal® Sealing Plug



For both low-pressure and high-pressure hole sealing applications  
High leak resistance  
Exceptional hole fill  
Efficient stem locking device  
Wide choice of installation tools

## Applications

Engine blocks, transmissions, cylinders, brakes, gear box, pneumatic systems, hydraulic blocks, compressors, pumps



## Installation Equipment

Genesis® nG2-S



ProSet® XT3 - coming soon



ProSet® XT4 - coming soon



7287



# Lockbolt Systems

## Benefits of assembly

POP Avdel two piece lockbolt systems are designed for high strength assembly. Quick and simple to place, they provide tamper-proof joints and are the ideal solution where spot welding is not practical or not possible. They are widely used in demanding engineering industries such as vehicle body building, railways, construction and containers. Key user benefits include:

- High speed assembly
- High shear and tensile strength
- Consistent high clamp
- Excellent vibration resistance
- Tamper-proof joints
- Quick and simple to install

## Typical placing sequence

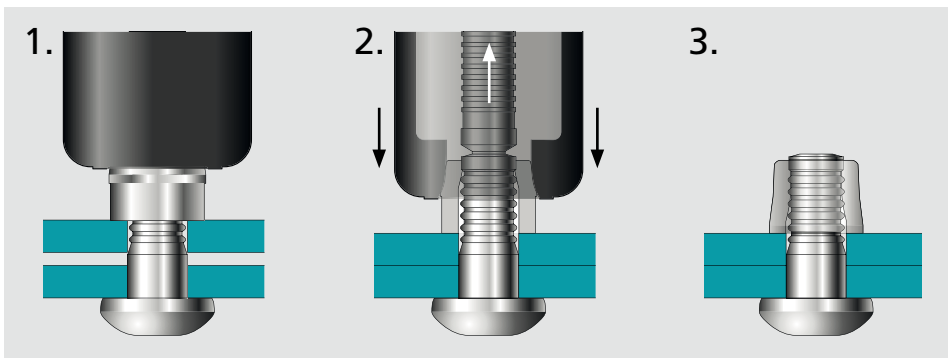

1. The fastener bolt is located in the hole and the collar placed over the stem. The tool is then located onto the stem.

2. Tool activation pulls the materials together and swages the collar into the grooves of the pin.

3. At a pre-determined load, the stem breaks flush with the top of the collar.

Please visit our website [StanleyEngineeredFastening.com](http://StanleyEngineeredFastening.com) for fastener placing animations.

## Assembly applications

- Agricultural equipment
- Automotive assemblies and components
- Building and construction
- Cabinets and enclosures
- Commercial vehicle bodies
- Domestic appliances
- Fencing
- Railway rolling stock
- Reefer cool and dry freight containers
- Solar & wind energy

Solar power plants



Steel construction



Commercial vehicles



Rail wagon for vehicle transportation



Ventilator frame



Container





## Range Overview

### NeoBolt®



No pin break  
High strength and superior vibration resistance  
Fast and consistent installation

### Avdelok®



High shear strength  
High controlled clamp

### Avdelok® XT



Exceptional shear and tensile strength  
Sizes from 12.7 mm (1/2") to 28.6 mm (1-1/8")

### Maxlok®



Wide grip range  
High shear strength

### Avtainer®



High shear strength  
Joins composite panels to metal  
Leak resistant  
High speed installation

## Lockbolt for blind sided assembly

### Avbolt®



Use on blind sided application  
High residual clamp force  
High tensile and shear strength  
Vibration resistance  
High grip capability

## Installation Equipment

73200



nG3 LB



7287



734 AV™

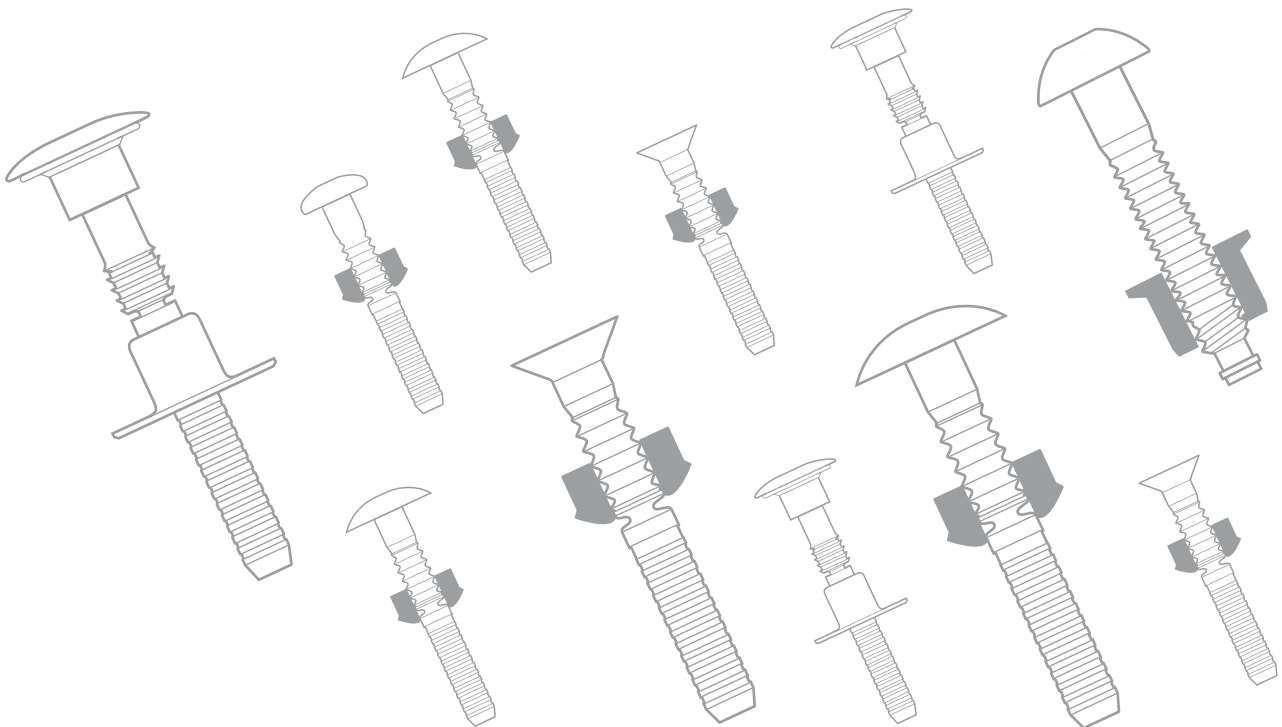

# Blind Rivet Nuts

## Benefits of assembly

POP Avdel blind rivet nuts and installation tools provide a quick, reliable and low cost system of inserting high quality, load bearing threads. The blind rivet nuts offer many benefits over weld nuts, self-tapping screws, pressed inserts and nuts & bolts. Key user benefits include:

- Blind sided assembly
- Reliable and secure thread installation
- No damage to surface coatings
- Reduced rework and wastage
- Lower cost of installation
- Suitable for use in stamped or drilled holes
- Designed for automation

## Typical placing sequence

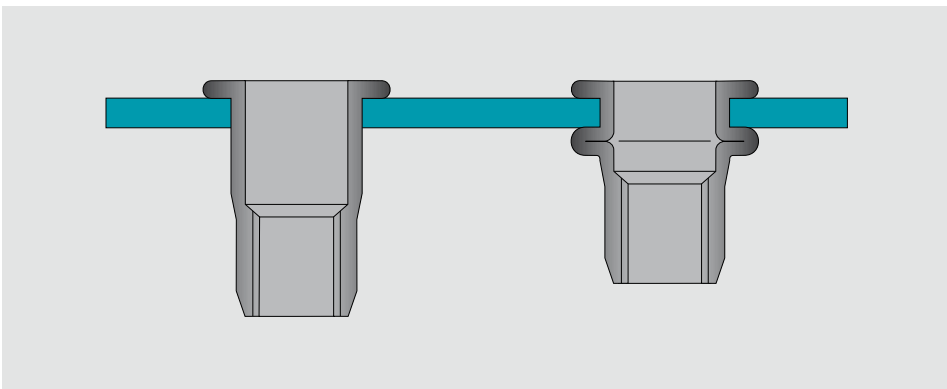

The rivet nut is threaded onto the drive screw of the installation tool and inserted into the prepared hole in the workpiece.

On activating the tool, the blind rivet nut is pulled towards the tool, forming the body wall radially outwards to clench tightly against the workpiece.

At a pre-determined torque, the drive screw of the tool reverses and is disengaged from the thread, leaving the rivet nut securely in position.

Please visit our website [StanleyEngineeredFastening.com](http://StanleyEngineeredFastening.com) for fastener placing animations.

## Assembly applications

- Adjustable feet/castors
- Automotive components
- Compressor units
- Computer chassis
- Door hinges
- Lawnmowers
- Lift cabins
- Number plates
- Radios
- Roof rack attachments
- Window frames

Suspension damper



Hydro formed cross beam



Handrail



Automotive crash structure



Washing machine



Gas burner



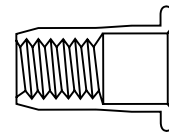

## Range Overview

POP Avdel blind rivet nuts are available in a variety of materials, head forms and body shapes and include well known brands like POP Nut®, Hexsert®, Eurosert®, Nutsert®, Squaresert®, Versa-Nut®, as well as Jack Nut® and Well-Nut®.

### Splined Body



Improves torque-to-turn resistance in softer materials such as aluminium when compared to plain body blind rivet nuts.

### Hexagonal Body



Improves torque-to-turn in components via form lock when compared to round and splined rivet nuts.

### Square Body



Improves torque-to-turn resistance in components via form lock due to even greater contact surface compared to round and splined blind rivet nus.

### Slotted Body



Slotted body forms four legs when placed. Extra large blind side bearing area. For use in composites and plastics.

### Closed End Body



Prevents the ingress of dirt and fluids into thread.

### Pipe POP Nut®



Designed to be installed in a pipe with the curved surface of a rear flange, creating a horizontal surface for subsequent component assembly.

### Large Flange



Provides a large load bearing surface to reinforce the hole and prevent push through.

### Low Profile



Allows near flush installation and clamp up without the need to prepare special holes.

### Countersunk



Allows flush installation and secure clamp up.

### Well Nut®



Rubber blind nuts ideal for isolating against vibration, electrical conductivity and galvanic corrosion and for selaing against ambient moisture and gases.

### Jack Nut®



Designed to be installed in soft or brittle materials such as plastic, cardboard or glass..

### Customised Designs



We can design and manufacture blind rivet nuts with a wide variety of forms and finishes:

- Special surface coatings
- Varying grip ranges, flange dimensions and nut lengths
- Closed end and sealed rivet ntus

## Installation Equipment

ProSert® XTN20



74200



74405



# STANLEY®

Engineered Fastening

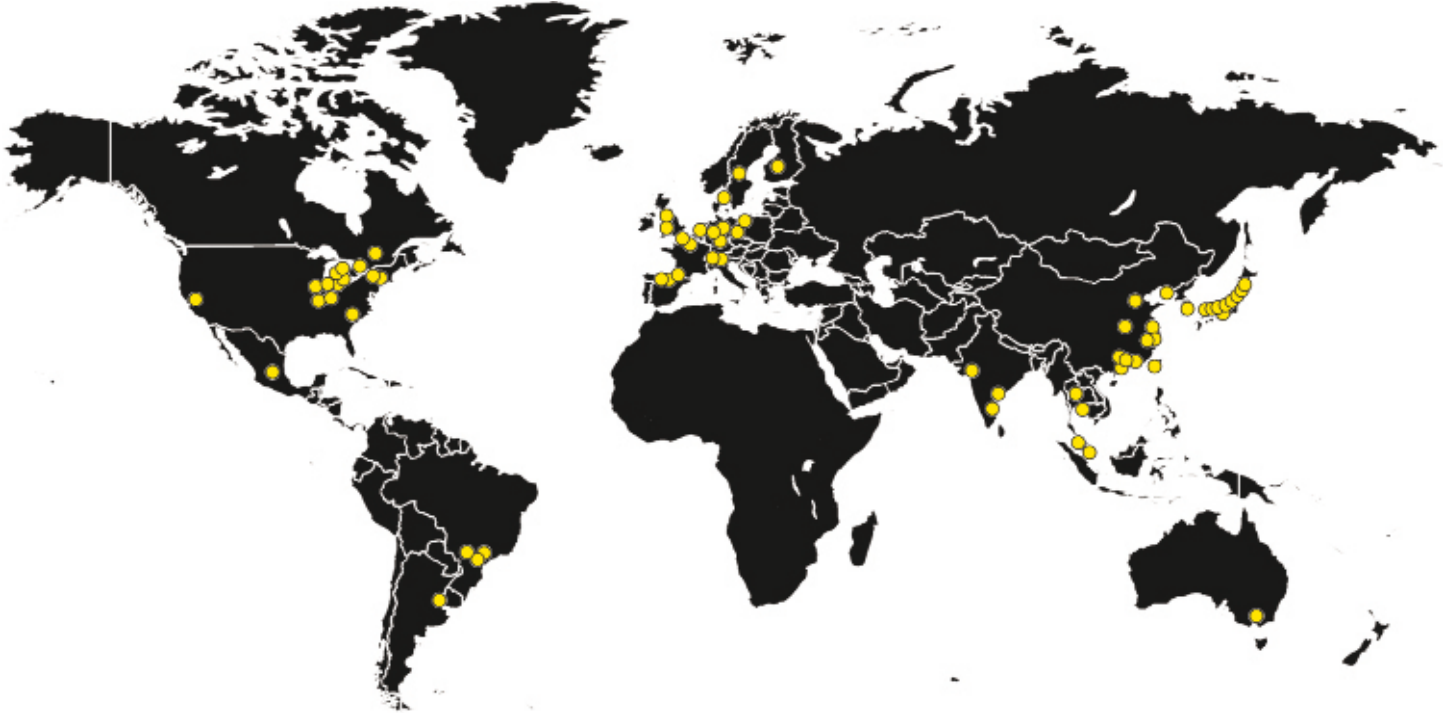

STANLEY Engineered Fastening, a Stanley Black & Decker Inc. Company has been revolutionizing fastening and assembly technologies for a variety of industries for more than 40 years.

For more information, please visit our website

**[StanleyEngineeredFastening.com](http://www.stanleyengineeredfastening.com)**

## Quick Links:

---

- ▶ Our locations  
<http://www.stanleyengineeredfastening.com/contact/global-locations>
- ▶ Request Information  
<http://www.stanleyengineeredfastening.com/econtact/request-information>
- ▶ Resource Center  
<http://www.stanleyengineeredfastening.com/resource-center>



© 2016 Stanley Black & Decker, Inc., Rev. 10.2016

Autosert®, AV™, Avbolt®, Avdel®, Avdelok®, Avdelmate®, Avex®, Avibulb®, Avinox®, Avimat®, Avlug®, Avseal®, Avsert®, Avtainer®, Avtronic®, Briv®, Bulbex®, Chobert®, Eurosert®, Genesis®, Grovit®, Hemlok®, Hexsert®, Interlock®, Jack Nut®, Klamp-Tite®, Maxlok®, Monobolt®, NeoBolt®, NeoSpeed®, Nutsert®, POP®, POP Nut®, ProSert®, ProSet®, Rivscrew®, Squaresert®, Stavex®, T-Lok®, Versa-Nut®, Well Nut®, and Holding your world together® are registered trademarks of Stanley Black & Decker, Inc. and its affiliates.

Data shown is subject to change without prior notice as a result of continuous product development and improvement policy. Your local STANLEY Engineered Fastening representative is at your disposal should you need to confirm latest information.