

# 3-Terminal Adjustable Output Positive Voltage Regulator

The PJ317 is adjustable 3-terminal positive voltage regulator capable of supplying in excess of 1.5 A over an output voltage range of 1.25 V to 37 V. This voltage regulator is exceptionally easy to use and require only two

external resistors to set the output voltage. Further, it employs internal current limiting, thermal shutdown and safe area compensation, making it essentially blow-out proof.

## FEATURES

- Output Adjustable between 1.25 V and 37 V
- Internal Thermal Overload Protection
- Internal Short-Circuit Current Limiting
- Constant with Temperature
- Output Transistor Safe-Area Compensation
- Floating Operation for High Voltage Applications
- Standard 3-lead Transistor Packages
- Eliminates Stocking Many Fixed Voltages

## ORDERING INFORMATION

Device	Operating Temperature	Package	Design Load Current
PJ317CZ	-20°C to 85°C	TO-220	1.5A
PJ317CM		TO-263	1.5A
PJ317CT		TO-92	0.1A
PJ317CP		TO-252	0.5A
PJ317CW		SOT-223	1A
PJ317CS		SOP-8	0.3A

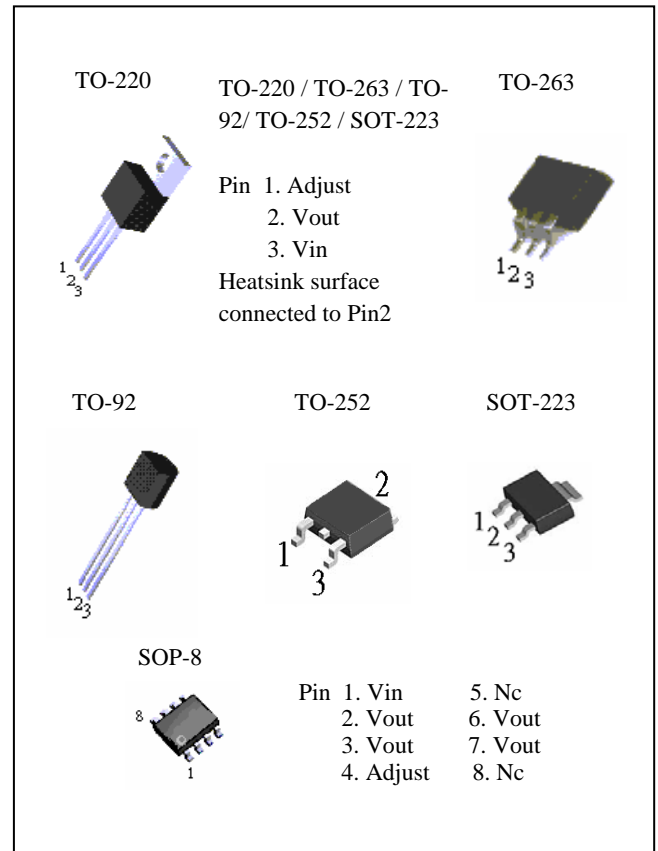

## CIRCUIT SCHEMATIC

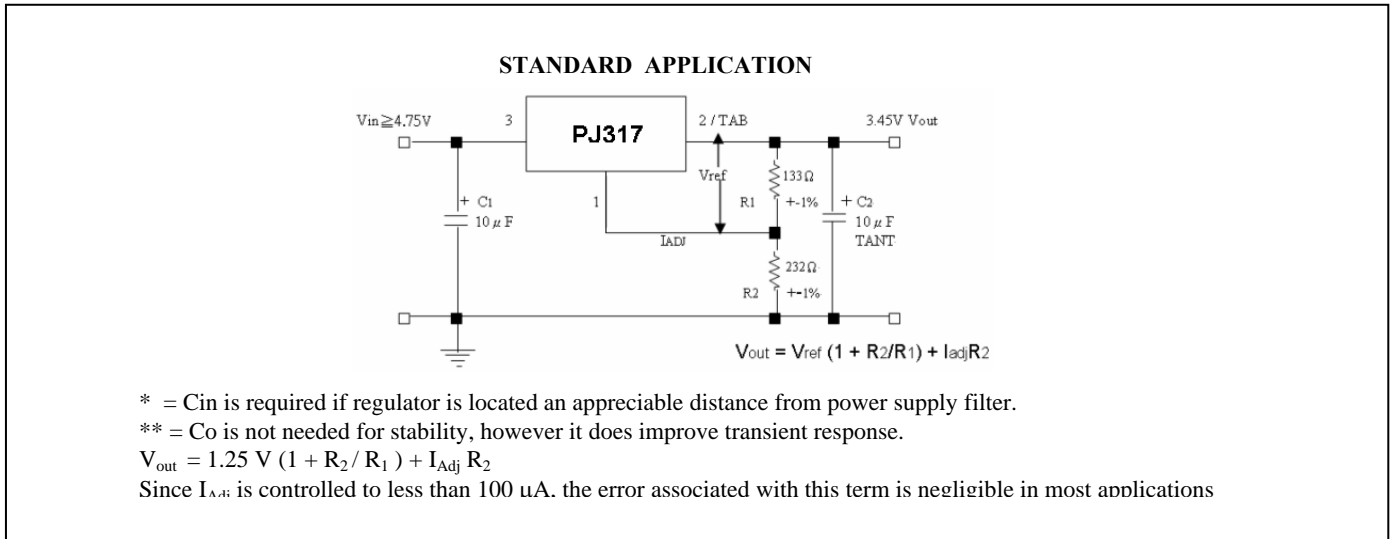

3-Terminal Adjustable Output Positive Voltage Regulator

**MAXIMUM RATINGS**

RATING	SYMBOL	VALUE	UNIT
Input-Output Voltage Differential	$V_I - V_O$	40	Vdc
Power Dissipation	$P_D$	Internally Limited	
Operating Junction Temperature Range	$T_J$	-20 to + 85	°C
Storage Temperature Range	$T_{stg}$	-65 to +150	°C

**PJ317 ELECTRICAL CHARACTERISTICS**

( $V_I - V_O = 5.0$  V;  $I_O = 0.5$ A for TO-220 packages;  $T_J = T_{low}$  to  $T_{high}$  [see Note 1];  $I_{max}$  and  $P_{max}$  per Note 2; unless otherwise specified.)

CHARACTERISTIC	FIGURE	SYMBOL	MIN.	TYP.	MAX.	UNIT
Line Regulation (Note 3) $T_A = 25^\circ\text{C}$ , $3.0\text{ V} \leq V_I - V_O \leq 40\text{ V}$	1	REGline	--	0.01	0.04	%/V
Load Regulation (Note 3) $T_A = 25^\circ\text{C}$ , $10\text{ mA} \leq I_O \leq I_{max}$ , $V_O \leq 5.0$ $V_O \geq 5.0$	2	REGload	--	5.0 0.1	25 0.5	mV %V
Thermal Regulation ( $T_A = 25^\circ\text{C}$ ) 20 ms Pulse			--	0.03	0.07	%W
Adjustment Pin Current	3	$\Delta I_{Adj}$	--	50	100	$\mu\text{A}$
Adjustment Pin Current Change, $P_D \leq P_{max}$ $10\text{mA} \leq I_L \leq I_{max}$ , $2.5\text{V} \leq V_I - V_O \leq 40\text{V}$	1.2	$I_{Adj}$	--	0.2	5.0	$\mu\text{A}$
Reference Voltage (Note 4), $P_D \leq P_{max}$ $10\text{mA} \leq I_O \leq I_{max}$ , $3.0\text{ V} \leq V_I - V_O \leq 40\text{ V}$	3	$V_{ref}$	1.20	1.25	1.30	V
Line Regulation (Note 3), $3.0\text{ V} \leq V_I - V_O \leq 40\text{V}$	1	REGline	--	0.02	0.07	%V
Current Limit ( $V_{IN} - V_{OUT}) \leq 15\text{V}$ Package CZ,CM Package CW Package CP Package CS Package CT				1.5 1 0.5 0.3 0.1		A
Temperature Stability ( $T_{low} \leq T_J \leq T_{high}$ )	3	$T_S$	--	1	--	%
Minimum Load Current to Maintain Regulation, ( $V_I - V_O = 40\text{ V}$ )	3	$I_{Lmin}$	--	3.5	10	mA
RMS Noise, % of $V_O$ $T_A = 25^\circ\text{C}$ , $10\text{ Hz} \leq f \leq 10\text{ KHz}$	--	N	--	0.003	--	%
Long-Term Stability, $T_J = T_{high}$ (Note 6) $T_A = 25^\circ\text{C}$ for Endpoint Measurements, 1000hrs	3	S	--	0.3	1.0	%
Thermal Resistance Junction to Case	--	$R_{\theta JC}$	--	5.0	--	°C /W

NOTES:

- (1)  $T_{low} = -20^\circ\text{C}$        $T_{high} = + 85^\circ\text{C}$
- (2)  $I_{max} = 1.5\text{ A}$        $P_{max}$ : TO-220=20W, TO-263=3W, TO-252=2W, SOP-8=0.625W, TO-92=0.625W, SOT-23=0.625W
- (3) Load and line regulation are specified at constant junction temperature. Changes in  $V_O$  due to heating effects must be taken into account separately. Pulse testing with low duty cycle is used.
- (4) Selected devices with tightened tolerance reference voltage available.
- (5)  $C_{Adj}$ , when used, is connected between the adjustment pin and ground.
- (6) Since Long-Term Stability cannot be measured on each device before shipment, this specification is an engineering estimate of average stability from lot to lot.

3-Terminal Adjustable Output Positive Voltage Regulator

SCHEMATIC DIAGRAM

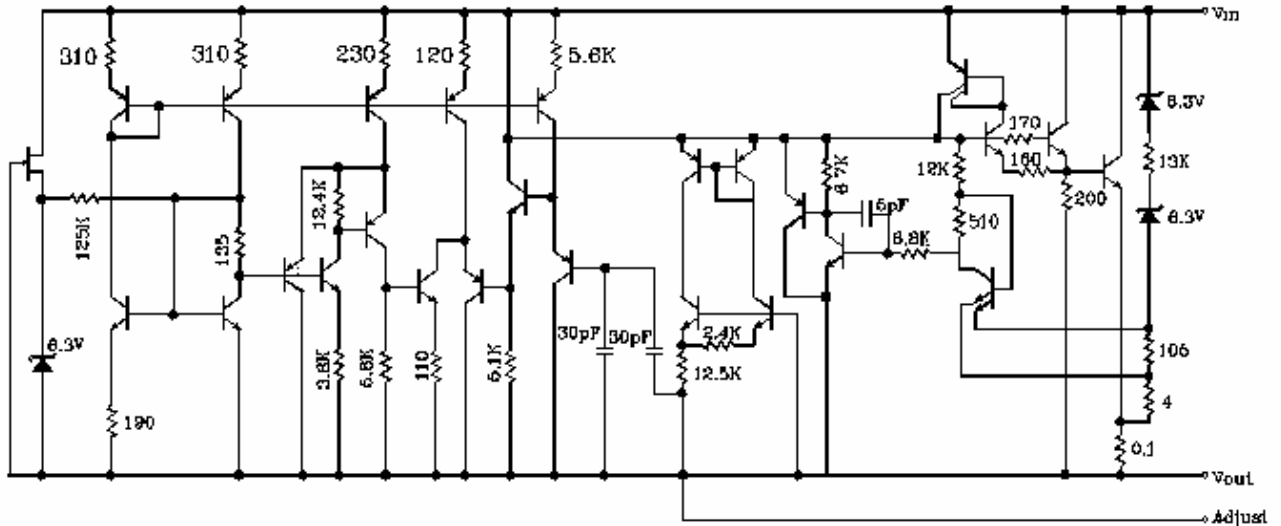
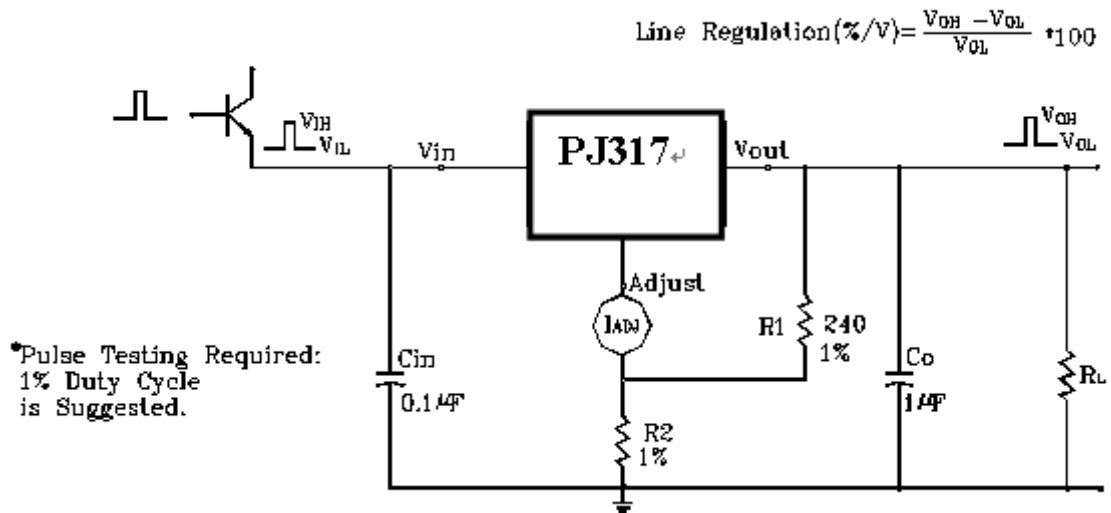

FIGURE 1- LINE REGULATION AND LINE TEST CIRCUIT



3-Terminal Adjustable Output Positive Voltage Regulator

FIGURE 2 - LOAD REGULATION AND  $\Delta L_{adj}$ /LOAD TEST CIRCUIT

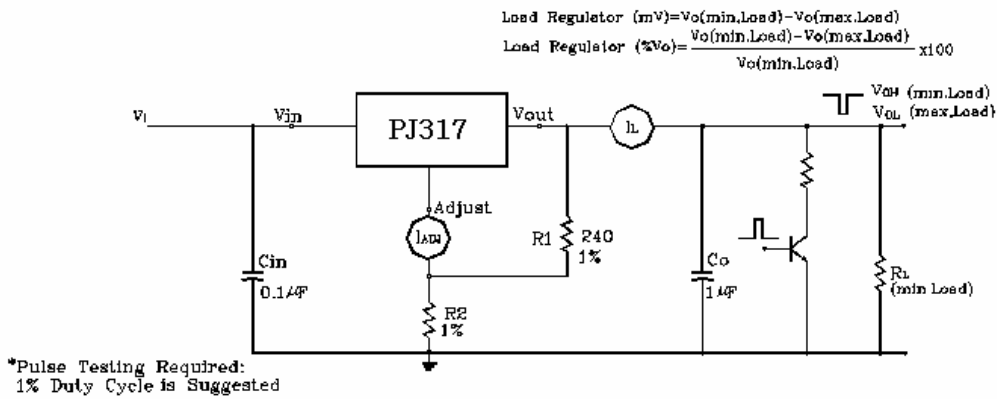

FIGURE 3 - STANDARD TEST CIRCUIT

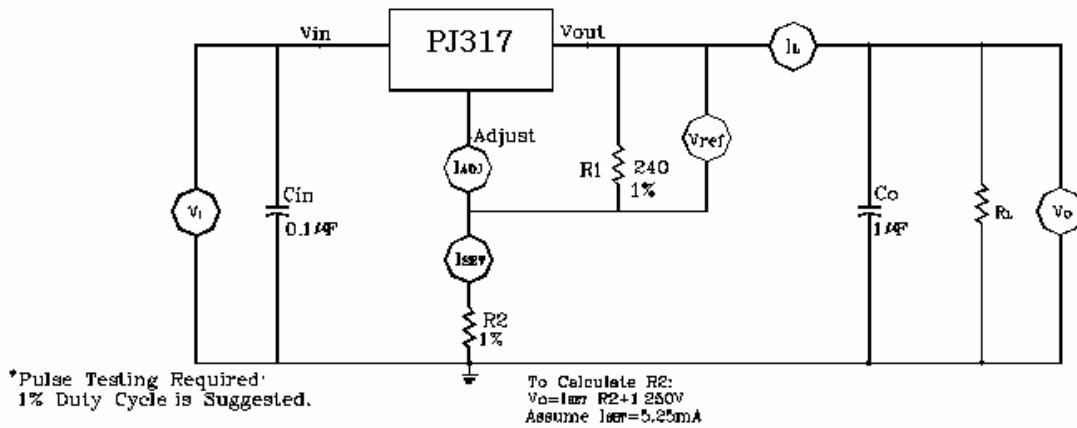
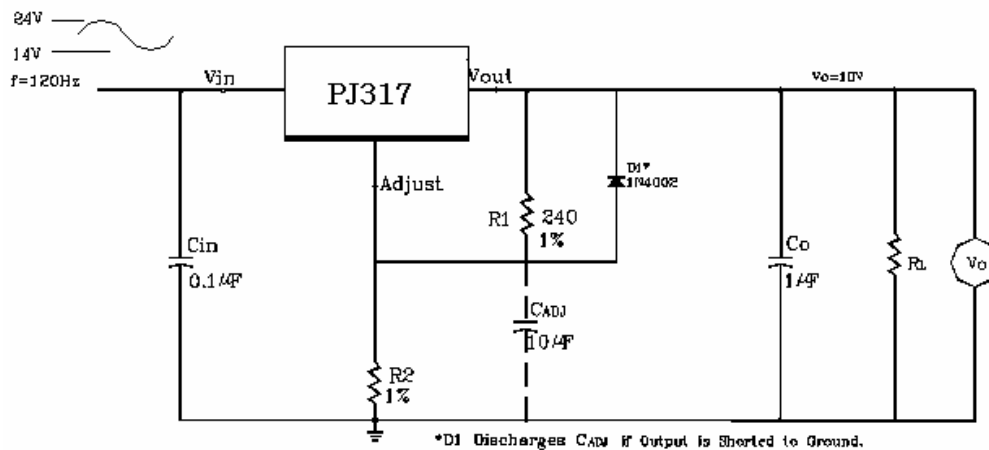

FIGURE 4 - RIPPLE REJECTION TEST CIRCUIT



3-Terminal Adjustable Output Positive Voltage Regulator

FIGURE 5-LOAD REGULATION

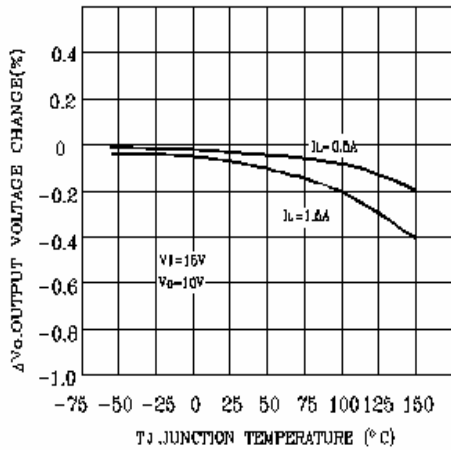

FIGURE 6-CURRENT LIMIT

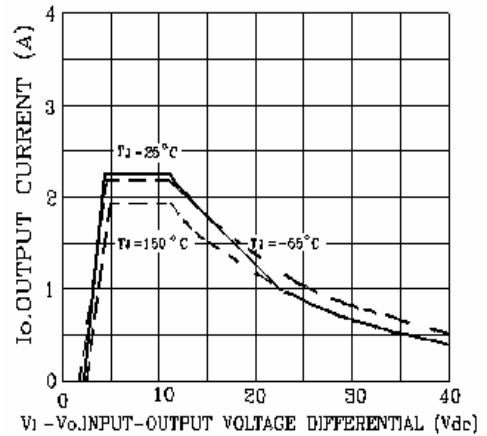

FIGURE 7-ADJUSTMENT PIN CURRENT

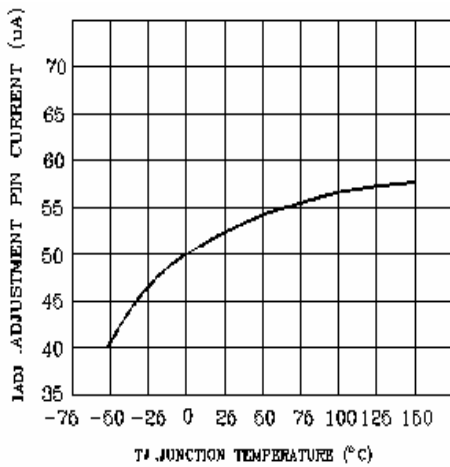

FIGURE 8-DROPOUT VOLTAGE

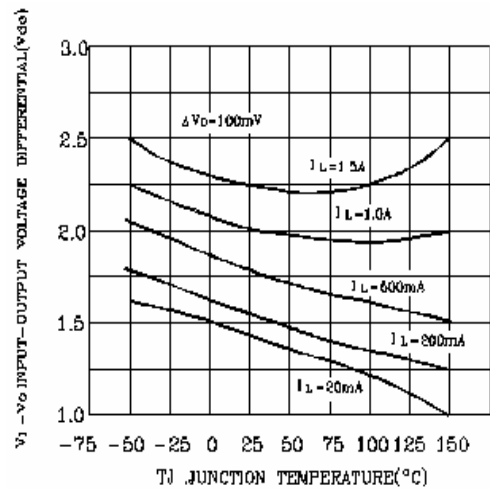

FIGURE 9-TEMPERATURE STABILITY CURRENT

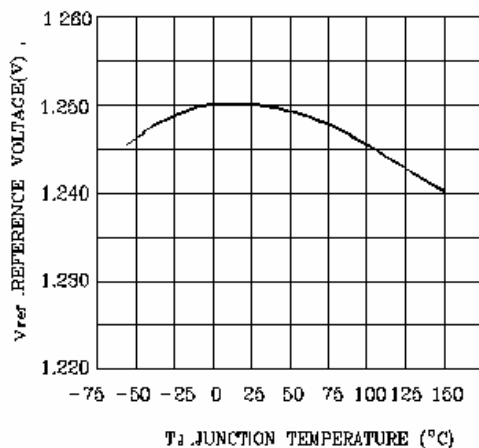
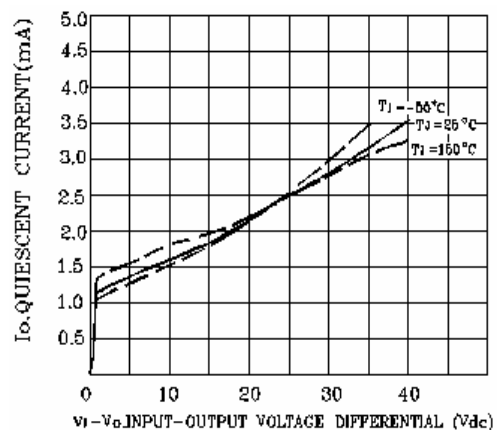

FIGURE 10-MINIMUM OPERATING



3-Terminal Adjustable Output Positive Voltage Regulator

FIGURE 11-RIPPLE REJECTION versus OUTPUT VOLTAGE

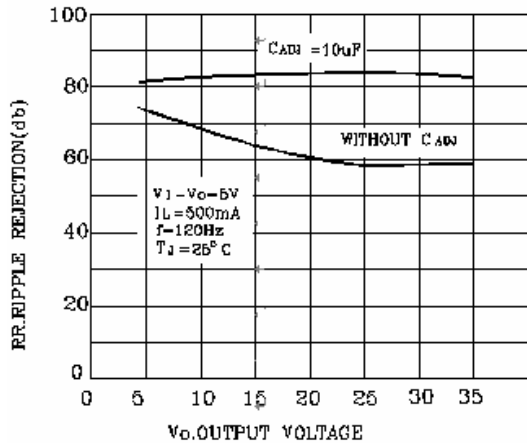

FIGURE 12-RIPPLE REJECTION versus OUTPUT CURRENT

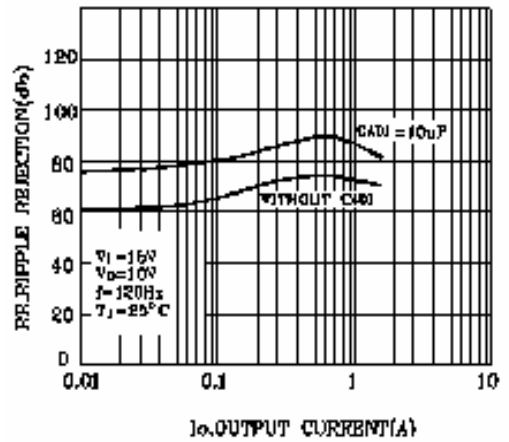

FIGURE 13-RIPPLE REJECTION versus FREQUENCY

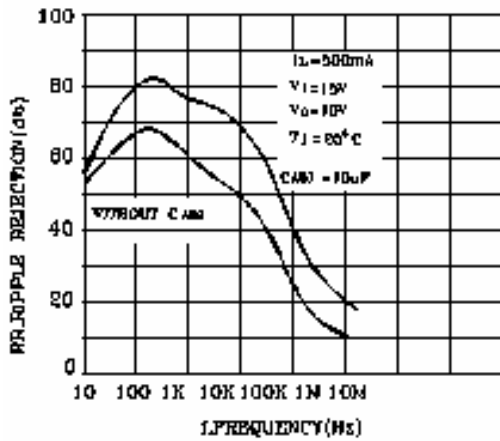

FIGURE 14-OUTPUT IMPEDANCE

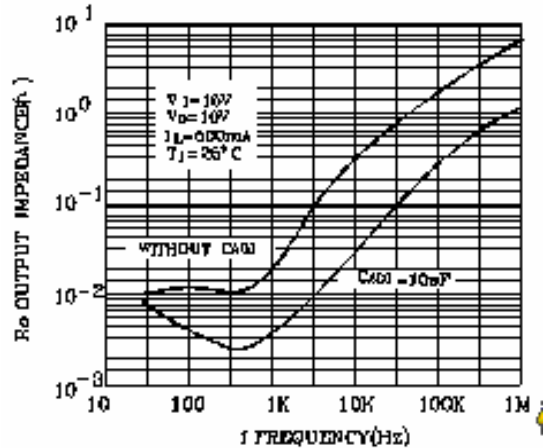

FIGURE 9-TEMPERATURE STABILITY

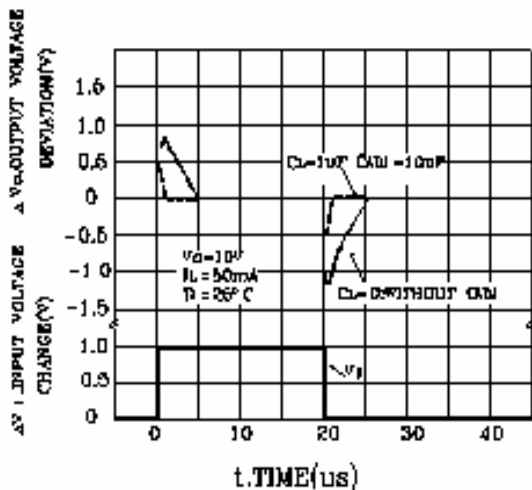
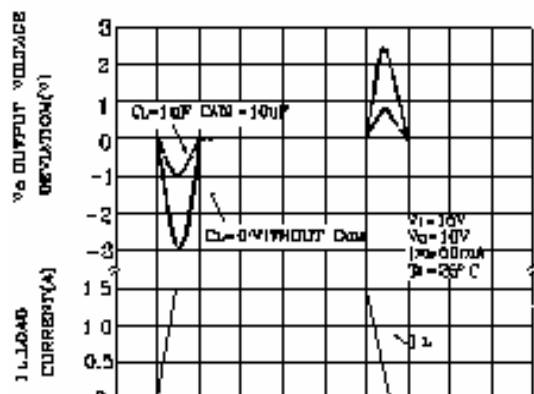

FIGURE 16-LOAD TRANSIENT RESPONSE



### 3-Terminal Adjustable Output Positive Voltage Regulator

#### BASIC CIRCUIT OPERATION

The PJ317 is a 3-terminal floating regulator. In operation, the PJ317 develops and maintains a nominal 1.25 volt reference ( $V_{ref}$ ) between its output and adjustment terminals. This reference voltage is converted to a programming current ( $I_{PROG}$ ) by  $R_1$  (see Figure 17), and this constant current flows through  $R_2$  to ground. The regulated output voltage is given by:

$$V_{out} = V_{ref} (1 + R_2 / R_1) + I_{Adj} R_2$$

Since the current from the adjustment terminal ( $I_{adj}$ ) represents an error term in the equation, the PJ317 was designed to control  $I_{adj}$  to less than 100  $\mu$ A and keep it constant. To do this, all quiescent operating current is returned to the output terminal. This imposes the requirement for a minimum load current. If the load current is less than this minimum, the output voltage will rise.

Since the PJ317 is a floating regulator, it is only the voltage differential across the circuit which is important to performance, and operation at high voltages with respect to ground is possible.

FIGURE 17 -BASIC CIRCUIT CONFIGURATION

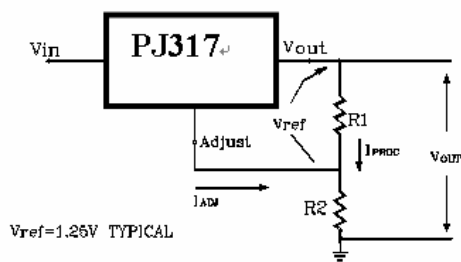

#### EXTERNAL CAPACITORS

A 0.1 $\mu$ F disc or 1 $\mu$ F tantalum input bypass capacitor ( $C_{in}$ ) is recommended to reduce the sensitivity to input line impedance.

The adjustment terminal may be bypassed to ground to improve ripple rejection. This capacitor ( $C_{ADJ}$ ) prevents ripple from being amplified as the output voltage is rejection about 15dB at 120 Hz in a 10 volt application.

Although the PJ317 is stable with no output capacitance, like any feedback circuit, certain values of external capacitance can cause excessive ringing. An output increased. A 10 $\mu$ F capacitor should improve ripple capacitance ( $C_O$ ) in the form of a 1  $\mu$ F tantalum or 25  $\mu$ F aluminum electrolytic capacitor on the output swamps this effect and insures stability.

#### PROTECTION DIODES

When external capacitors are used with any I.C. regulator it is sometimes necessary to add protection diodes to prevent the capacitors from discharging through low current points into the regulator.

Figure 18 shows the PJ317 with the recommended protection diodes for output voltages in excess of 25 V or high capacitance values ( $C_O > 25 \mu$ F,  $C_{ADJ} > 10\mu$ F). Diode  $D_1$  prevents  $C_O$  from discharging thru the I.C. during an input short circuit. Diode  $D_2$  protects against capacitor  $C_{ADJ}$  discharging through the I.C. during an output short circuit. The combination of diodes  $D_1$  and  $D_2$  prevents  $C_{ADJ}$  from discharging through the I.C. during an input short circuit.

FIGURE 18 - VOLTAGE REGULATOR WITH PROTECTION DIODES

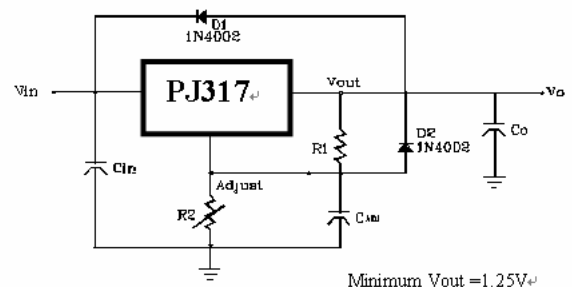

D1 Protects the device during an input short circuit

The PJ317 is capable of providing extremely good load regulation, but a few precautions are needed to obtain maximum performance. For best performance, the programming resistor ( $R_1$ ) should be connected as close to the regulator as possible to minimize line drops which effectively appear in series with the reference, thereby degrading

### 3-Terminal Adjustable Output Positive Voltage Regulator

regulation . The ground end of R<sub>2</sub> can be returned near the load ground to provide remote ground sensing and improve load regulation.

FIGURE 19 - "LABORATORY" POWER SUPPLY WITH ADJUSTABLE CURRENT LIMIT AND OUTPUT VOLTAGE

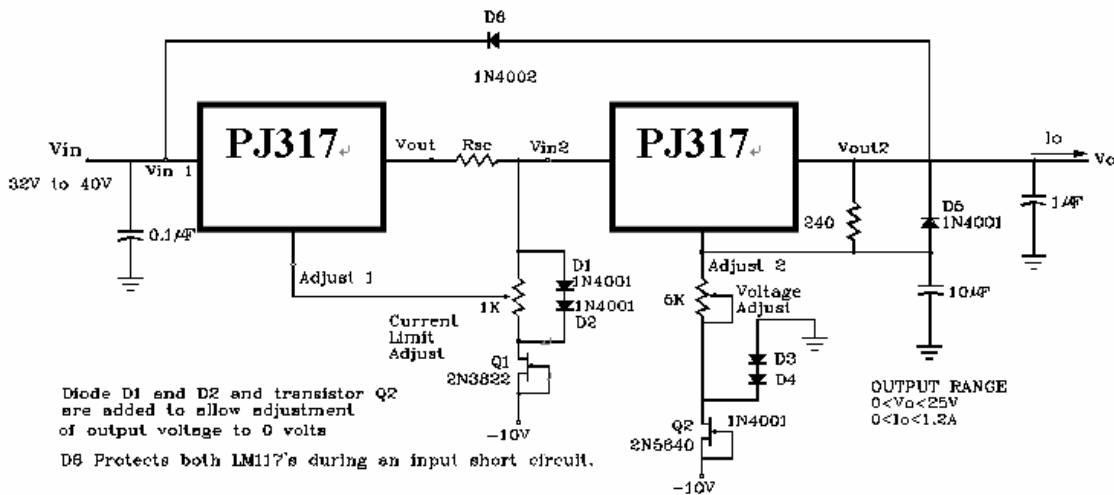

FIGURE 20-ADJUSTABLE CURRENT LIMITER

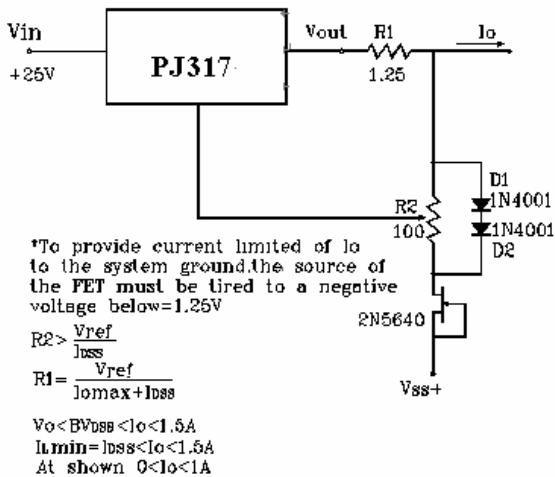
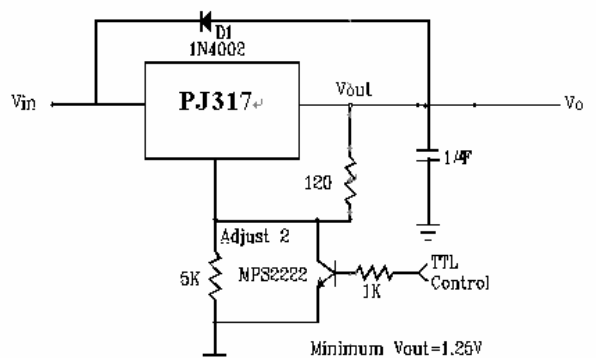

FIGURE 21-5V ELECTRONIC SHUT DOWN REGULATOR



D1 protects the device during an input short circuit

FIGURE 22-SLOW TURN-ON REGULATOR

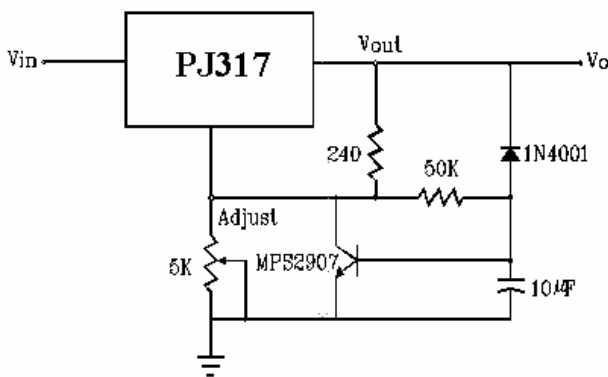
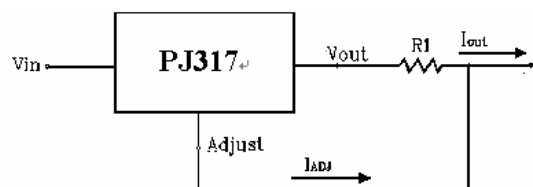
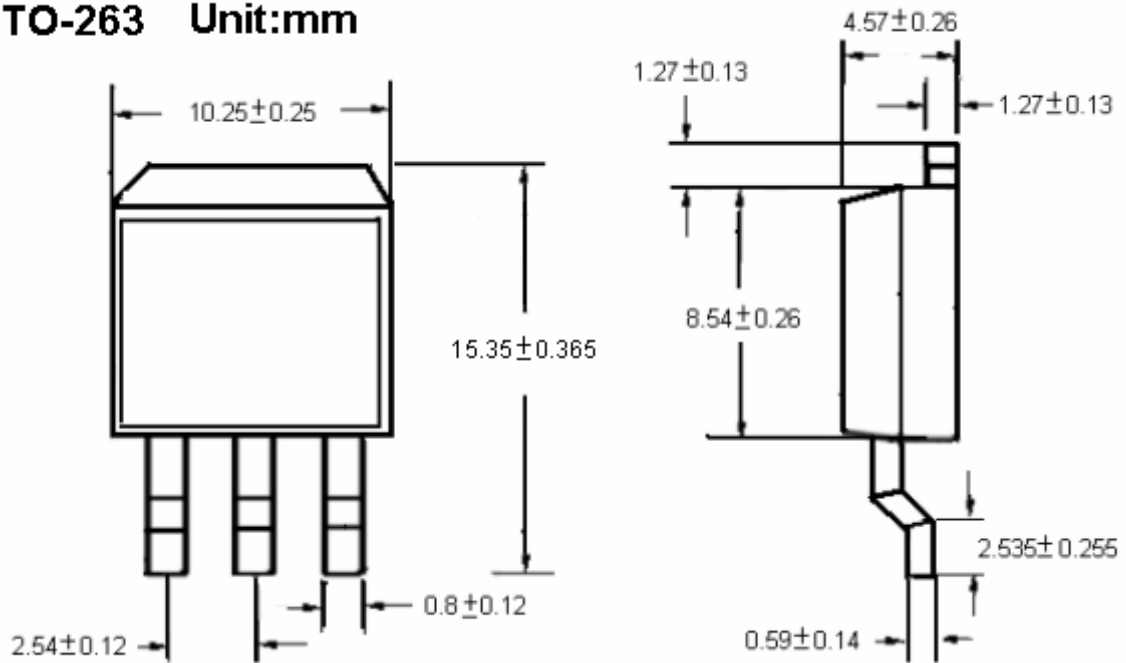

FIGURE 23-CURRENT REGULATOR



3-Terminal Adjustable Output Positive Voltage Regulator

TO-263 Unit:mm



TO-252 Unit:mm

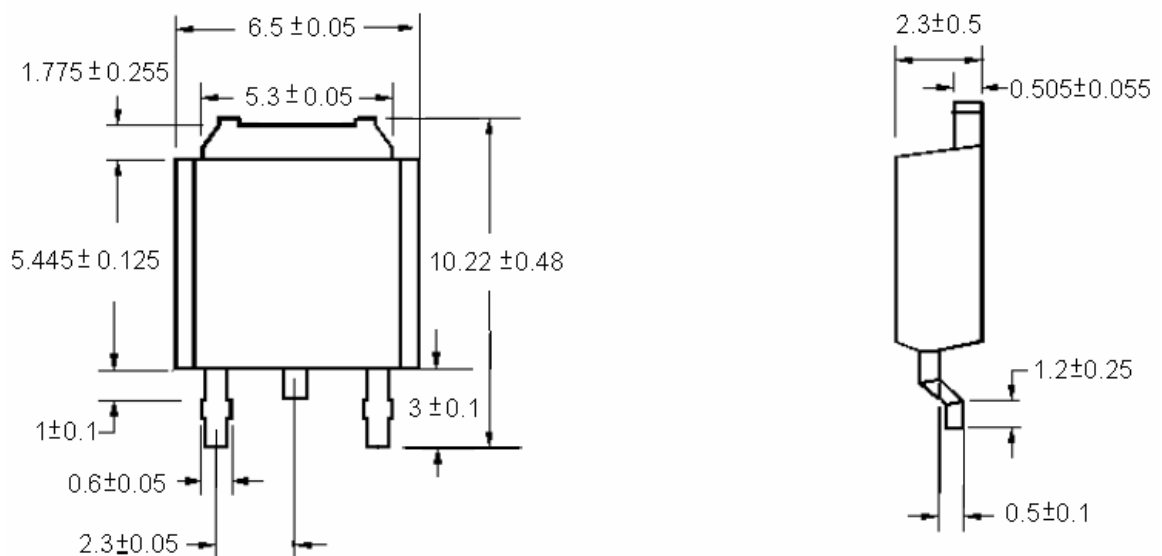

3-Terminal Adjustable Output Positive Voltage Regulator

TO-220 Unit:mm

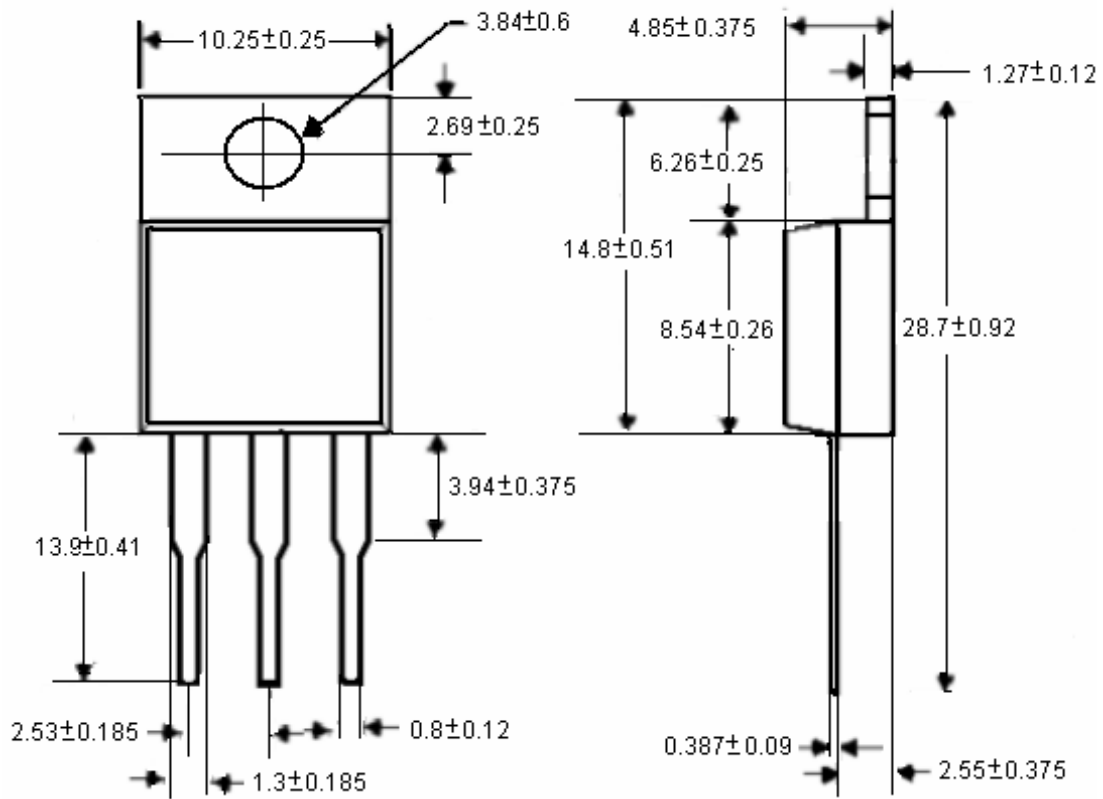

TO-92 Unit:mm

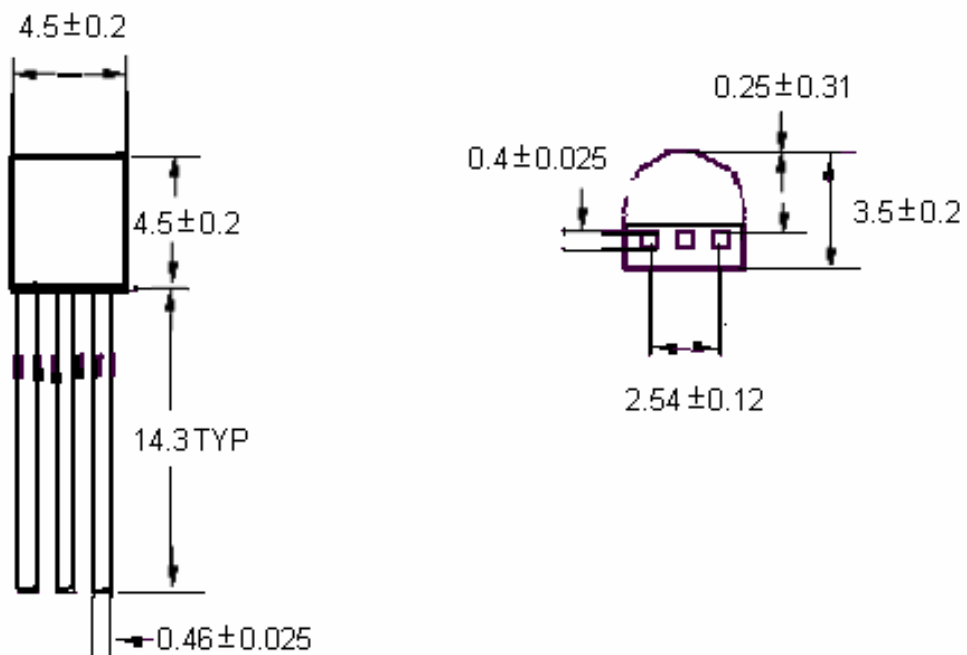

3-Terminal Adjustable Output Positive Voltage Regulator

SOT-223 Unit:mm

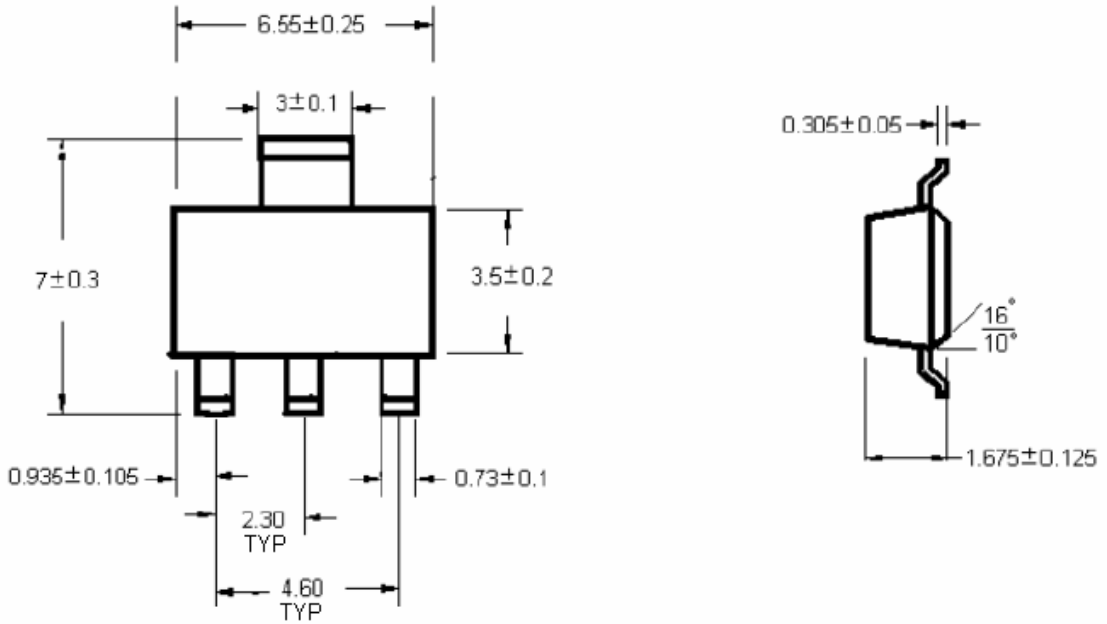

SOP-8

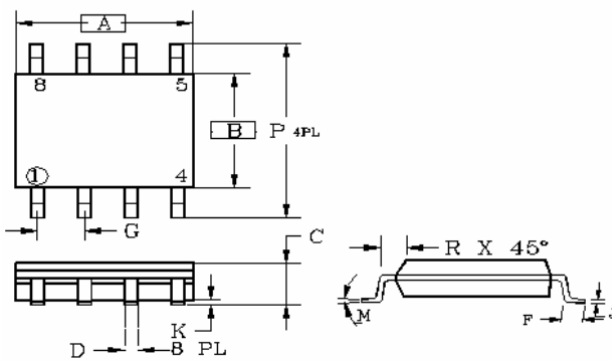

DIM	MILLIMETERS		INCHES	
	MIN	MAX	MIN	MAX
A	4.80	5.00	0.189	0.196
B	3.80	4.00	0.150	0.157
C	1.35	1.75	0.054	0.068
D	0.35	0.49	0.014	0.019
F	0.40	1.25	0.016	0.049
G	1.27BSC		0.05BSC	
K	0.10	0.25	0.004	0.009
M	0°	7°	0°	7°
P	5.80	6.20	0.229	0.244
R	0.25	0.50	0.010	0.019