

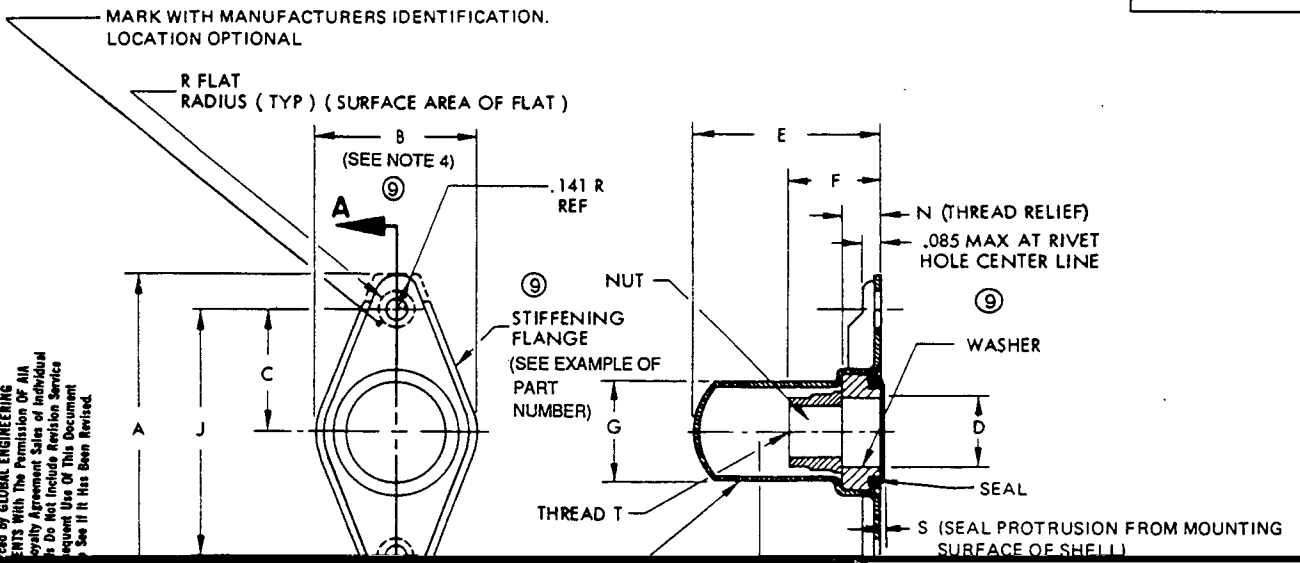

FED SUP CLASS 5310



AEROSPACE INDUSTRIES ASSOCIATION OF AMERICA, INC. 150 EYE STREET, N.W. WASHINGTON, D.C. 20005

Read by GLOBAL ENGINEERING FIRMS With The Permission of AIA. No Responsibility is assumed for any errors. Do Not include Revision Services subsequent Use of This Document. See if it has been Revised.

June 1981 9 Dec. 1992

AEROSPACE INDUSTRIES ASSOCIATION OF AMERICA, INC.
1260 EYE STREET, N.W.
WASHINGTON, D.C. 20005

THIS DRAWING SUPERSEDES ALL ANTECEDENT STANDARD DRAWINGS FOR THE SAME PRODUCT AND SHALL BECOME EFFECTIVE NO LATER THAN SIX MONTHS FROM THE LAST DATE OF APPROVAL SHOWN HEREON.

- MATERIAL:**
- NUT** - STEEL, SEE PROCUREMENT SPECIFICATION. NONMAGNETIC A-286 CRES (UNS S66286) PER AMS5525 OR AMS5732.
 - SHELL** - STEEL, SEE PROCUREMENT SPECIFICATION. NONMAGNETIC A-286 CRES (UNS S66286) PER AMS5525.
 - WASHER** - ALUMINUM ALLOY OR STEEL, SEE PROCUREMENT SPECIFICATION. NONMAGNETIC A-286 CRES (UNS S66286) PER AMS5525 OR AMS5732.
 - SEAL** - 225 DEGREES F: RUBBER, MIL-R-6855, CLASS 1, GRADE 60, DUROMETER A60, COLOR BLACK
- 350 DEGREES F: FLUROSILICONE RUBBER, MIL-R-25988, TYPE II, CLASS 1, DUROMETER A70, COLOR BLUE
- 450 DEGREES F: SILICONE RUBBER, AMS3304, DUROMETER A70, COLOR RED

FINISH: STEEL NUT, SHELL AND WASHER-CADMIUM PLATE PER QQ-P-416, TYPE II, CLASS 2.
CRES NUT, SHELL AND WASHER-CLEAN AND PASSIVATE PER MIL-S-5002. WHEN CODED C (SEE EXAMPLE OF PART NUMBER, NUT-SILVER PLATE PER MIL-N-25027 TO A MINIMUM THICKNESS ON SURFACES WHICH CAN BE TOUCHED BY A .7500(3/4- INCH) BALL. THREADS SHALL SHOW COMPLETE COVERAGE BUT THICKNESS REQUIREMENT ON THREADS IS WAIVED
ALUMINUM ALLOY WASHER - ANODIZE OR CHEMICAL FILM PER MIL-N-25027, EXCEPT ANODIZE SHALL BE LIMITED TO TYPE 1 OR TYPE II. APPROVED DRY FILM LUBRICANT ON NUTS WHEN CODED AS EXPLAINED ON SHEET 2

EXAMPLE OF PART NUMBER

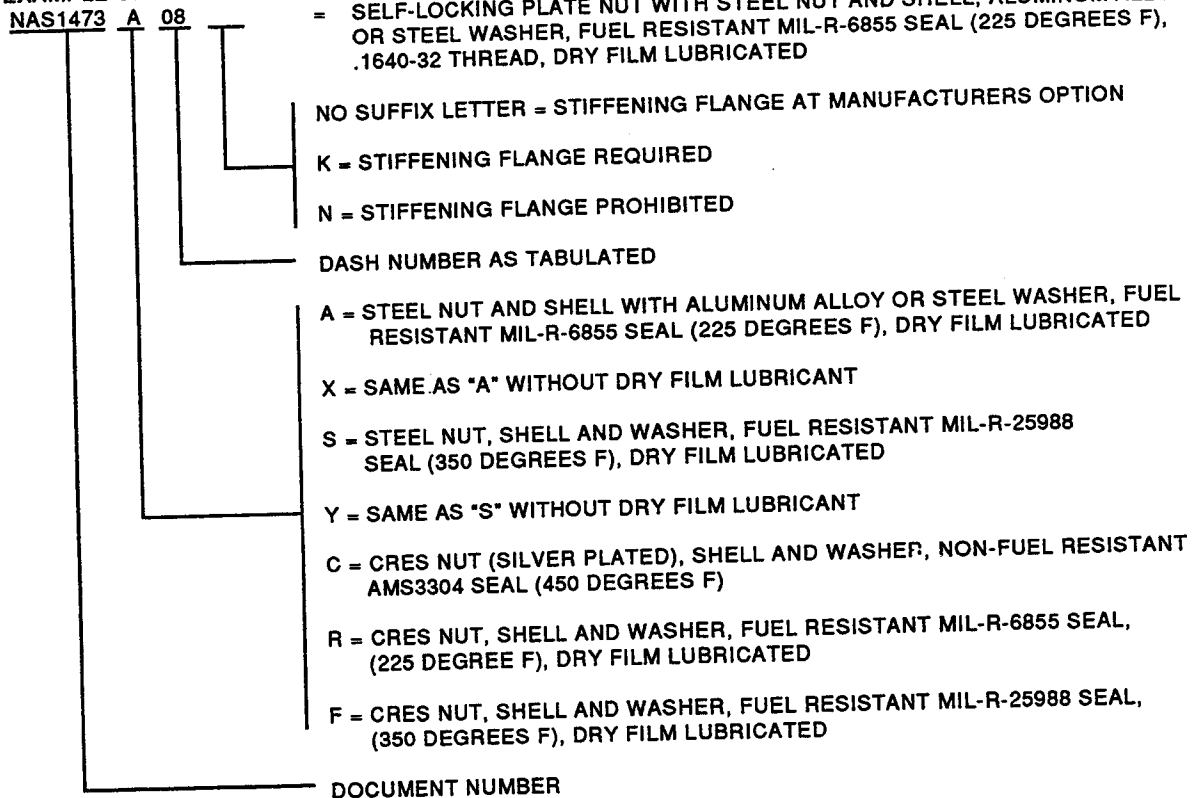

- FLOAT:** MINIMUM RADIAL FLOAT .020.
MAXIMUM AXIAL FLOAT .030.
- PRESSURE RANGE:** 0 TO 50 PSIG.
- TEMPERATURE RANGE:** MIL-R-6855 RUBBER (-65 DEGREES F TO 225 DEGREES F).
MIL-R-25988 FLUROSILICONE RUBBER (-65 DEGREES F TO 350 DEGREES F).
AMS3304 RUBBER (-65 DEGREES F TO 450 DEGREES F).
- THREADS:** THREADS IN ACCORDANCE WITH MIL-S-8879 BEFORE LUBRICATION.
- MARKING:** THE SMALLEST CONTAINER USED TO PACKAGE "A", "X" AND "R" CODED PARTS SHALL BE MARKED WITH THE CURE DATE(QUARTER AND YEAR) OF THE OLDEST RUBBER SEAL CONTAINED THEREIN. THE AGE OF RUBBER SEALS SHALL NOT EXCEED 20 QUARTERS AT THE TIME OF DELIVERY TO THE CONTRACTOR.

⑧ COMPLETELY REVISED

NAS1473

SHEET 2 OF 3

APPROVAL DATE JUNE 1960 REVISION ③ 15 APRIL 1968 ④ 31 DEC. 1968 ⑤ 16 DEC. 1974 ⑥ 15 JUNE 1976 ⑦ 8 JUNE 1981 ⑧ 9 Dec. 1992



NOTES:

1. THREAD ELEMENT SHALL BE CAPABLE OF ENGAGEMENT WITH A BOLT IN THE MAXIMUM MISALIGNED POSITION.
2. NUT AND SHELL SHAPE OPTIONAL, WITHIN SPECIFIED MAXIMUM DIMENSIONS.
3. MAGNETIC PERMEABILITY OF CRES NUTS SHALL BE LESS THAN 2.0 (AIR = 1,0) FOR A FIELD STRENGTH H = 200 OERSTEDS. MAGNETIC PERMEABILITY INDICATOR PER MIL-I-17214 OR EQUIVALENT.
4. B DIMENSION MAY BE .015 LARGER THAN MAX VALUES SHOWN IN TABLE FOR ITEMS WITH STIFFENING FLANGE.

PERFORMANCE: QUALIFICATION TEST

- 1.0 ALL REQUIREMENTS OF MIL-N-25027 PERTAINING TO STEEL FLOATING PLATE NUTS INCLUDING AXIAL STRENGTH REQUIREMENTS OF TABLE I FOR REGULAR STEEL NUTS, SHALL APPLY TO THIS PART EXCEPT THE MAXIMUM TEMPERATURE SHALL BE 225 DEGREES F, 350 DEGREES F AND 450 DEGREES F, AS APPLICABLE. A POSITIVE SEAL SHALL BE REQUIRED AFTER TESTING PER PARAGRAPH 3.9 (PUSH OUT) AND 3.8.3 (TORQUE OUT) OF MIL-N-25027. THE PUSH OUT AND TORQUE OUT TESTS SHALL BE CARRIED TO A PROOF LOAD EQUAL TO THE REQUIREMENTS FOR THE APPLICABLE SIZE. ALL TESTS SHALL BE PERFORMED ON A SINGLE SHEET OF 2024-T3 OR 7075-T6 ALUMINUM ALLOY, NOMINAL THICKNESS OF .312 INCHES, AND HAVING A MINIMUM OF TEN (10) INCHES SQUARE (100 SQUARE INCHES) UNSUPPORTED AREA.

SIX (6) NUTS SHALL BE EQUALLY SPACED ON A CIRCLE HAVING A DIAMETER OF SEVEN AND ONE HALF (7-1/2) INCHES. THE NUTS SHALL BE ATTACHED TO THE PLATE BY SOCKET HEAD CAP SCREWS THREADED INTO BLIND HOLES TAPPED TO A DEPTH OF APPROXIMATELY .218 INCHES. #3-48 SCREWS SHALL BE USED FOR PARTS WITH .098 INCH DIAMETER RIVET HOLES AND #5-40 SOCKET HEAD CAP SCREWS SHALL BE USED FOR PARTS WITH .130 INCH DIAMETER RIVET HOLES. THE #3-48 SCREWS SHALL BE SEATED TO FOURTEEN (14) INCH-POUNDS AND THE #5-40 SCREWS TO EIGHTEEN (18) INCH-POUNDS. INSTALL BOLTS IN NUTS USING A SEATING TORQUE THREE (3) TIMES THE MAXIMUM LOCKING TORQUE OF MIL-N-25027. THREE (3) NUTS SHALL BE TESTED WITH BOLTS INSTALLED AND THREE (3) WITH BOLTS REMOVED.

- 2.0 A POSITIVE SEAL SHALL BE CONSIDERED TO MEAN NO LEAKAGE BY VISUAL EXAMINATION, USING DYED LIQUID, WHEN SUBJECTED TO A STATIC DIFFERENTIAL PRESSURE OF 50 PSI +2 -0 PSI FOR A PERIOD OF FIVE (5) MINUTES MINIMUM. THE LIQUIDS USED SHALL BE FUELS CONFORMING TO MIL-J-5624 OR TT-S-735, TYPE III FOR 225 DEGREES F AND 350 DEGREES F SEALS, AND METHYL ALCOHOL FOR 450 DEGREES F SEALS. IN ADDITION, A CYCLING TEST SHALL BE PERFORMED CONSISTING OF A CYCLING PRESSURE OF BETWEEN 0 AND 50 PSI FOR 1000 CYCLES, A CYCLE BEING COMPLETED APPROXIMATELY EVERY TWELVE (12) SECONDS.
- 2.1 A POSITIVE SEAL SHALL BE PROVIDED AFTER AGING AN EMPTY TEST FIXTURE WITH NUTS MOUNTED IN A HOT AIR FURNACE AT 450 DEGREES F +/- 10 DEGREES F, 350 DEGREES F +/- 10 DEGREES F, 225 DEGREES F +/- 10 DEGREES F, AS APPLICABLE FOR A PERIOD OF 4 HOURS +/- 10

AEROSPACE INDUSTRIES ASSOCIATION OF AMERICA, INC.
1250 EYE STREET, N.W.
WASHINGTON, D.C. 20005

IS SAME PRODUCT AND
E OF APPROVAL SHOWN

1968 5 8 June 1981 6 9 Dec. 1992

