

# CHERRY® NUT PLATE RIVETS



CHERRY

**CHERRY®**  
**AEROSPACE**

*SPS Fastener Division, a PCC Company*

## LIMITED WARRANTY

Seller warrants that the goods conform to applicable specifications and drawings and will be manufactured and inspected according to generally accepted practices of companies manufacturing industrial or aerospace fasteners. In the event of any breach of the foregoing warranty, Buyer's sole remedy shall be to return defective goods (after receiving authorization from Seller) for replacement or refund of the purchase price, at the Seller's option. Seller agrees to any freight costs in connection with the return of any defective goods, but any costs relating to removal of the defective or nonconforming goods or installation of replacement goods shall be Buyer's responsibility. SELLER'S WARRANTY DOES NOT APPLY WHEN ANY PHYSICAL OR CHEMICAL CHANGE IN THE FORM OF THE PRODUCT IS MADE BY BUYER. THE FOREGOING EXPRESS WARRANTY AND REMEDY ARE EXCLUSIVE AND ARE IN LIEU OF ALL OTHER WARRANTIES AND REMEDIES; ANY IMPLIED WARRANTY AS TO QUALITY, FITNESS FOR PURPOSE, OR MERCHANTABILITY IS HEREBY SPECIFICALLY DISCLAIMED AND EXCLUDED BY SELLER. This warranty is void if seller is not notified in writing of any rejection of the goods within one (1) Year after initial use by buyer of any power Riveter or ninety (90) days after initial use of any other product. Seller shall not be liable under any circumstances for incidental, special or consequential damages arising in whole or in part from any breach by Seller, AND SUCH INCIDENTAL, SPECIAL, OR CONSEQUENTIAL DAMAGES ARE HEREBY EXPRESSLY EXCLUDED.

Our policy is one of continuous development. Specifications shown in this document may be subject to changes introduced after publication.

CHERRY® is a trademark of Cherry Aerospace.

# CHERRY® NUT PLATE RIVETS

CCR244/264/274 (INCH)

CCMR244/264/274 (METRIC)

## CONTENTS

### Features and Specifications

Cherry Nut-Plate Blind Rivet Description .....	2
Technical Data .....	3

### Standard Pages

#### Inches

Universal Head .....	4
100° Flush Head .....	5
NAS1097 100° Flush Head .....	6

#### Metric

Universal Head .....	7
100° Flush Head .....	8
NAS1097 100° Flush Head .....	9

### Tooling

Hole Preparation and Tool Selection .....	10
Installation Tooling .....	11
Pulling Heads .....	12

## NOTE

The properties, strengths, dimensions, installed characteristics and all other information in this catalog is for guidance only to aid in the correct selection of the products described herein and is not intended or implied as part of the warranty. All applications should be evaluated for functional suitability and available samples of the described parts can be requested for installed tests, suitability and evaluations.

## ATTENTION

Blind rivets are not always a suitable substitute for solid rivets. Maintenance personnel are reminded that AC 43.13-1A chapter 2, section 3, stipulates: "Do not substitute hollow rivets for solid rivets in load carrying members without specific approval of the application by a representative of the Federal Aviation Administration. Blind rivets may be used in blind locations in accordance with the conditions listed in Chapter 5, provided the edge distances and spacings are not less than the minimum listed in paragraph 99d."

# CHERRY® NUT PLATE RIVETS

## FEATURES AND SPECIFICATIONS

- Low Cost
- Wide Grip Range
- Meets NASM25027
- Three Head Styles
- Single Action Tooling



The Cherry Nut-Plate family of fasteners offers an extensive range of head styles in a low cost, pull through style rivet. Rivet heads include the CCR/CCMR274, "Universal", CCR/CCMR264, 100° Flush, and the CCR/CCMR244, 100° Reduced Flush head (NAS 1097). Sleeve materials include C1018 steel or A-286 CRES stainless steel. Single action installation tools are all that is required to complete this low cost fastening system. Recommended installation tools include the G29 hand tool, which is sold complete with pulling head, or the G902/G902-15 lightweight power tool with pulling heads sold separately.

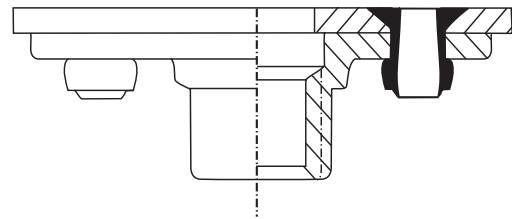

## NUMBERING SYSTEM

Cherry Part Number Example (Inch):

**CCR 264 CS -4 -04 PR**

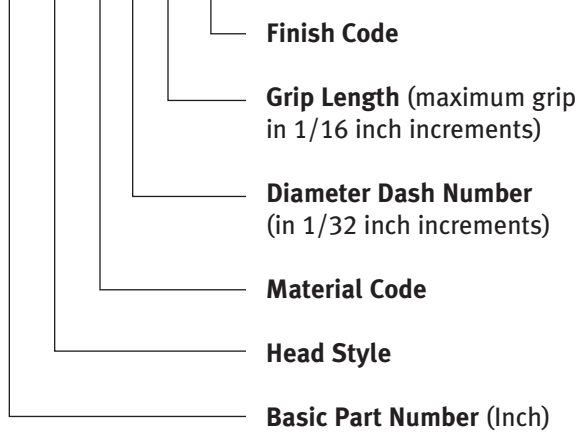

Cherry Part Number Example (Metric):

**CCMR 244 CS -25 -020 PR**

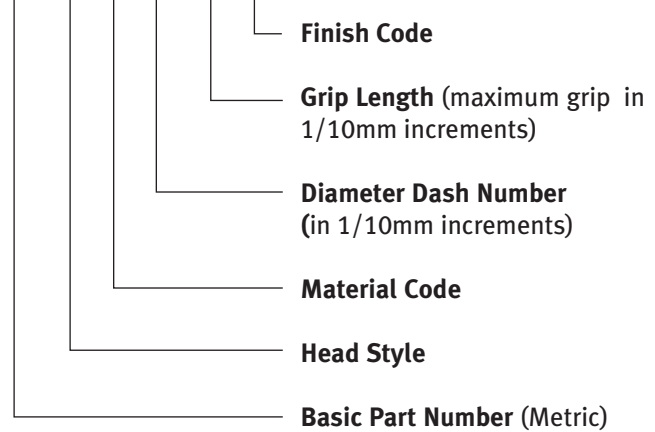

# CHERRY® NUT PLATE RIVETS

## TECHNICAL DATA

### FINISHES

FINISH CODE	SLEEVE	STEM
<b>STAINLESS STEEL PRODUCTS</b>	<b>A-286 CRES PER AMS 5731</b>	<b>305 CRES PER ASTM A-493</b>
NONE (NO SUFFIX)	SOLID FILM LUBE PER AS5272 PASSIVATE PER AMS 2700	PASSIVATE PER AMS 2700
IPR	CAD PLATE PER AMS QQ-P-416 TYPE II CL.2 GREEN PAR 90	PASSIVATE PER AMS 2700 PAR 90
P1	ALUMINUM COAT PER NAS 4006	PASSIVATE PER AMS 2700
PR	PASSIVATE PER AMS 2700 PAR 90 OR BARE	PASSIVATE PER AMS 2700 PAR 90 OR BARE
RK	RIVET KOTE® ICS201	PASSIVATE PER AMS 2700 PAR 90
T2	PASSIVATE PER AMS 2700 TIOLUBE 460	PASSIVATE PER AMS 2700 TIOLUBE 460
XL	PASSIVATE PER AMS 2700	PASSIVATE PER AMS 2700 LUBECO 905
ZN	NON LUBRICATED ZINC NICKEL PLATE PER BAC5637 TYPE II, CLASS 2 OR AMS2417 TYPE 2	PASSIVATE PER AMS 2700
<b>STEEL PRODUCTS</b>	<b>C1018 STEEL PER ASTM A-510 ANNEALED</b>	<b>CARBON STEEL PER ASTM A-510</b>
NONE (NO SUFFIX)	CAD PLATE PER AMS QQ-P-416 TYPE II CL.2	AS REQUIRED FOR CORROSION PROTECTION
P1	ALUMINUM COAT PER NAS4006	AS REQUIRED FOR CORROSION PROTECTION
C	CAD PLATE PER AMS QQ-P-416 TYPE II CL.2	CAD PLATE PER AMS QQ-P-416 , TYPE II CL.2
CPR	CAD PLATE PER AMS QQ-P-416 TYPE II CL.2 GREEN PAR 90	CAD PLATE PER AMS QQ-P-416 , TYPE II CL.2 PAR 90 OR BARE

**TABLE 1**

Strength requirements – CCR274 (Class 1), CCR264 (Class 2), CCR244 (Class 3)

Rivet Material	Head Class	Minimum Shear (lbs.)		Minimum Tensile (lbs.)		Minimum Torque Out (in-lbs.)		Minimum Push Out (lbs.)	
		-3	-4	-3	-4	-3	-4	-3	-4
SS (1018 Steel)	1 & 2	105	185	155	270	100	240	125	125
	3	105	185	100	225	100	240	125	125
CS (A-286)	1 & 2	105	185	155	270	100	240	125	125
	3	105	185	155	270	100	240	125	125

**TABLE 2**

Strength values – CCMR274 (Class 1),  
CCMR264 (Class 2), CCMR244 (Class 3)

Nominal Diameter Size	Minimum Shear Strength (all classes)		Minimum Tensile Strength (all classes)	
	(Pounds)	(Newtons)	(Pounds)	(Newtons)
	-25	115	510	168
-30	166	735	242	1075
-35	225	1000	329	1460

**TABLE 3**

Nut Plate Materials

Part Number	CS		SS	
	Sleeve	Stem	Sleeve	Stem
CCR274 CCR264 CCR244 CCMR274 CCMR264 CCMR244	A-286 PER AMS 5731	305 CRES PER ASTM A-493	C-1018 STEEL PER ASTM A-510	CARBON STEEL PER ASTM A-510

# CHERRY® NUT PLATE RIVETS

## CCR274/NASM20470 UNIVERSAL HEAD

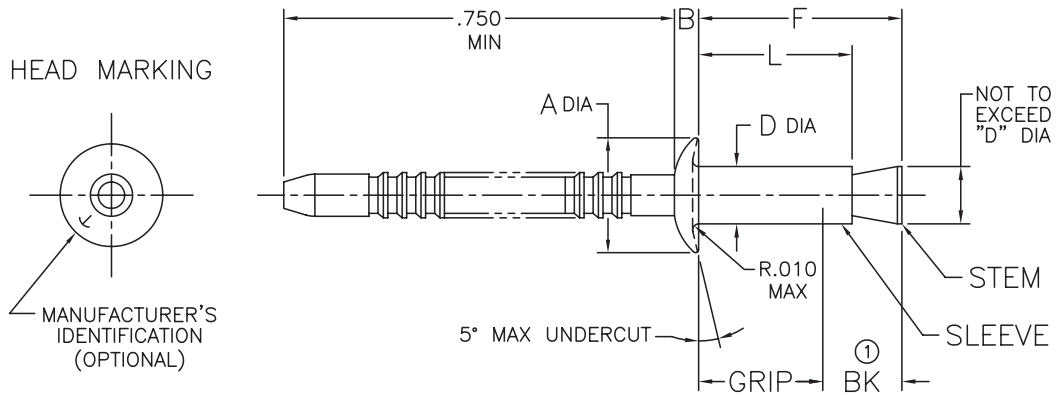

Diameter Dash No.	A		B		D		BK <sup>①</sup>	Hole Size	
	Min	Max	Min	Max	Min	Max		Min	Max
-3	.178	.196	.040	.050	.092	.097	.140	.097	.101
-4	.238	.262	.054	.064	.123	.128	.170	.129	.132

Grip Dash Number	Grip range		-3 Diameter				-4 Diameter			
			L Max	F Max	Installed Weight per 1000 pcs		L Max	F Max	Installed Weight per 1000 pcs	
	Min	Max			kgs	lbs			kgs	lbs
-01	.015	.062	.140	.218	.100	.22	.170	.256	.390	.86
-02	.063	.125	.203	.281	.132	.29	.232	.318	.440	.97
-03	.126	.187	.265	.343	.163	.36	.295	.381	.480	1.08
-04	.188	.250	.328	.405	.195	.43	.357	.443	.540	1.19
-05	.251	.312	.390	.468	.227	.50	.420	.506	.590	1.30
-06	.313	.375	.453	.530	.259	.57	.482	.568	.640	1.41
-07	.376	.437	.515	.592	.290	.64	.544	.630	.689	1.52
-08	.438	.500	.578	.655	.322	.71	.607	.693	.739	1.63
-09 <sup>②</sup>	.501	.562	.640	.718	.353	.78	.670	.755	.789	1.74
-10 <sup>②</sup>	.563	.625	.703	.780	.385	.85	.732	.818	.839	1.85
-11 <sup>②</sup>	.626	.687	.765	.843	.417	.92	.795	.899	.889	1.96
-12 <sup>②</sup>	.688	.750	.828	.905	.449	.99	.857	.961	.938	2.07

① "BK" is the minimum blind side clearance needed for satisfactory installation.

② Available on special order only.

# CHERRY® NUT PLATE RIVETS

## CCR264/NASM20426 100° FLUSH HEAD

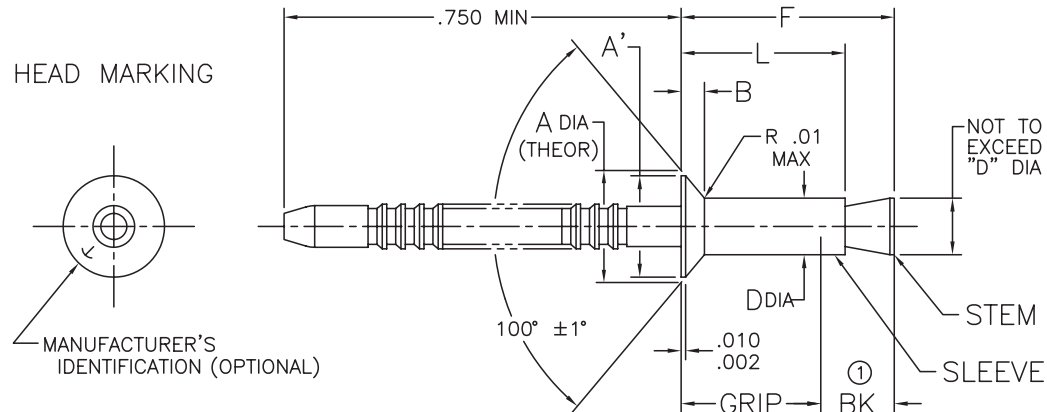

Diameter Dash No.	A Max	A' Actual Min	B Ref	D		BK <sup>①</sup>	Hole Size	
				Min	Max		Min	Max
-3	.179	.151	.036	.092	.097	.140	.097	.101
-4	.225	.197	.042	.123	.128	.170	.129	.132

Grip Dash Number	Grip range		-3 Diameter				-4 Diameter			
			L Max	F Max	Installed Weight per 1000 pcs		L Max	F Max	Installed Weight per 1000 pcs	
	kgs	lbs			kgs	lbs				
-01	.046	.062	.140	.218	.068	.15	.170	.256	.231	.51
-02	.063	.125	.203	.281	.100	.22	.232	.318	.281	.62
-03	.126	.187	.265	.343	.132	.29	.295	.381	.331	.73
-04	.188	.250	.328	.405	.163	.36	.357	.443	.381	.84
-05	.251	.312	.390	.468	.195	.43	.420	.506	.431	.95
-06	.313	.375	.453	.530	.227	.50	.482	.568	.476	1.05
-07	.376	.437	.515	.592	.259	.57	.544	.630	.526	1.16
-08	.438	.500	.578	.655	.290	.64	.607	.693	.576	1.27
-09 <sup>②</sup>	.501	.562	.640	.718	—	—	.670	.755	—	—
-10 <sup>②</sup>	.563	.625	.703	.780	—	—	.732	.818	—	—
-11 <sup>②</sup>	.626	.687	.765	.843	—	—	.795	.899	—	—
-12 <sup>②</sup>	.688	.750	.828	.905	—	—	.857	.961	—	—

① "BK" is the minimum blind side clearance needed for satisfactory installation.

② Available on special order only.

# CHERRY® NUT PLATE RIVETS

## CCR244/NAS1097 100° REDUCED FLUSH HEAD

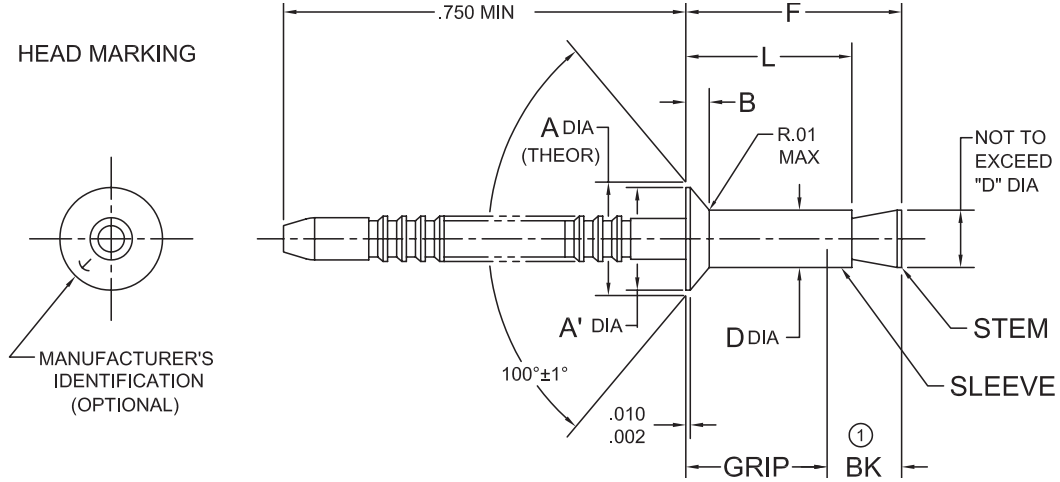

Diameter Dash No.	A Max	A' Actual Min	B Ref	D		BK <sup>①</sup>	Hole Size	
				Min	Max		Min	Max
-3	.148	.126	.021	.092	.097	.140	.097	.101
-4	.196	.174	.028	.123	.128	.170	.129	.132

Grip Dash Number	Grip range		-3 Diameter				-4 Diameter			
			L ±.010	F Max	Installed Weight per 1000 pcs		L ±.010	F Max	Installed Weight per 1000 pcs	
	Min	Max			kgs	lbs			kgs	lbs
-01	.046	.062	.130	.250	.059	.13	.160	.343	.222	.49
-02	.063	.125	.193	.313	.091	.20	.222	.406	.272	.60
-03	.126	.187	.255	.375	.122	.27	.285	.468	.322	.71
-04	.188	.250	.318	.437	.154	.34	.347	.531	.372	.82
-05	.251	.312	.380	.500	.186	.41	.410	.593	.422	.93
-06	.313	.375	.443	.562	.218	.48	.472	.656	.472	1.04
-07	.376	.437	.505	.625	.249	.55	.535	.718	.517	1.14
-08	.438	.500	.568	.688	.281	.62	.597	.781	.567	1.25

① "BK" is the minimum blind side clearance needed for satisfactory installation.

HEAD MARKING

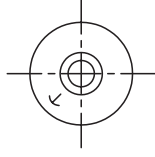

MANUFACTURER'S  
IDENTIFICATION  
(NOT REQUIRED FOR -.25 DIA)

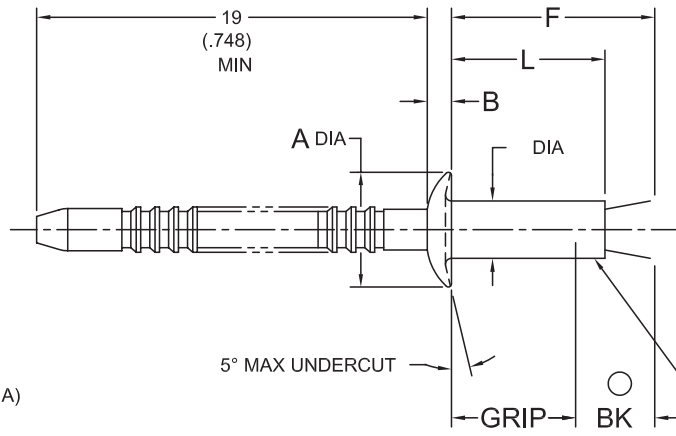

# METRIC NUT-PLATE RIVETS®

## CCMR264/NASM20426 100° FLUSH HEAD

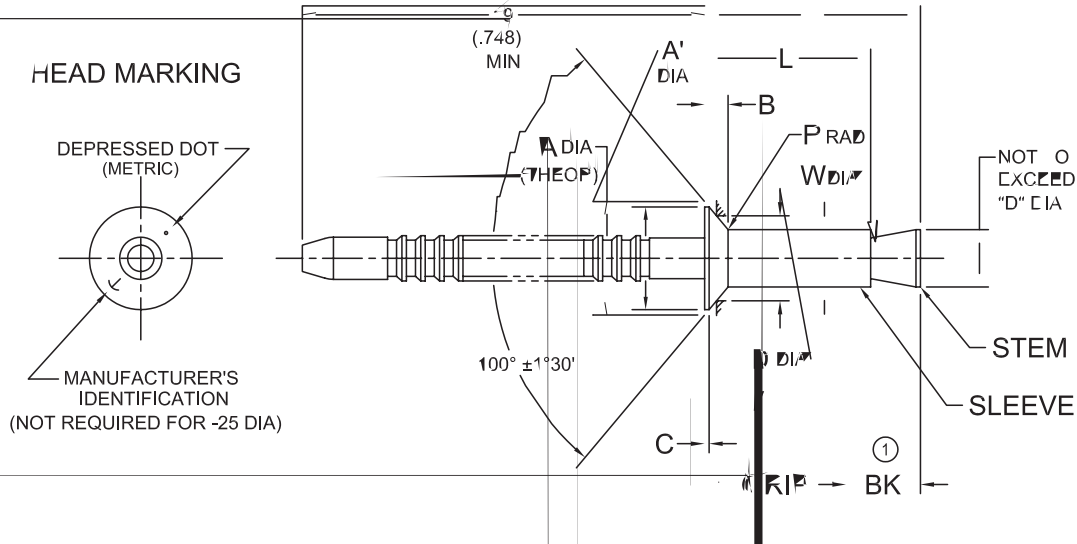

Diameter Dash No.	Nominal Diameter	A' Max	A' Actual Min	B Ref	BK <sup>①</sup>	C Min	D		R		V Protruding	W	Hole Size
							Min	Max	Min	Max	+0,00 (.000) -0,08 (.003)	Gage	
-25	2,5 (.098)	4,65 (.183)	4,15 (.163)	0,91 (.036)	4,2 (.165)	0,05 (.0020)	2,420 (.095)	2,480 (.098)	0,1 (.004)	0,3 (0.1)	0,32 (.013)	3,86 (.152)	2,560-2,500 mm (.101-.098")
-30	3,0 (.118)	5,55 (.219)	4,95 (.195)	1,07 (.042)	4,6 (.181)	0,06 (.0025)	2,920 (.115)	2,980 (.117)	0,2 (.008)	0,4 (0.1)	0,44 (.017)	4,50 (.177)	3,060-3,000 mm (.120-.118")
-35	3,5 (.138)	6,50 (.256)	5,80 (.228)	1,26 (.050)	4,9 (.193)	0,07 (.0028)	3,400 (.134)	3,470 (.137)	0,2 (.008)	0,4 (0.1)	0,56 (.022)	5,14 (.202)	3,575-3,500 mm (.141-.138")

Grip range		Grip Dash Number	-25 (2.5 mm) Diameter			-30 (3.0 mm) Diameter			-35 (3.5 mm) Diameter		
Min	Max		L Max	F Max	Weight kgs per 1000 pcs	L Max	F Max	Weight kgs per 1000 pcs	L Max	F Max	Weight kgs per 1000 pcs
1,17 (.046)	2,00 (.079)	-020	3,76 (.148)	5,99 (.236)	0,114	4,19 (.165)	6,38 (.251)	0,187	4,52 (.178)	7,42 (.292)	0,293
2,01 (.079)	4,00 (.157)	-040	5,74 (.226)	7,95 (.313)	0,154	6,10 (.240)	8,33 (.328)	0,245	6,48 (.255)	9,37 (.369)	0,376
4,01 (.158)	6,00 (.236)	-060	7,72 (.304)	9,96 (.392)	0,194	8,13 (.320)	10,34 (.407)	0,302	8,48 (.344)	11,38 (.448)	0,458
6,01 (.237)	8,00 (.315)	-080	9,75 (.384)	11,99 (.472)	0,234	10,16 (.400)	12,37 (.487)	0,360	10,52 (.414)	13,41 (.528)	0,541
8,01 (.315)	10,00 (.394)	-100	11,79 (.464)	14,02 (.552)	0,273	12,19 (.480)	14,40 (.567)	0,418	12,55 (.494)	15,44 (.608)	0,624
10,01 (.394)	12,00 (.472)	-120	13,82 (.544)	16,05 (.632)	0,313	14,22 (.560)	16,43 (.647)	0,476	14,58 (.574)	17,48 (.688)	0,707
12,01 (.473)	14,00 (.551)	-140	15,85 (.624)	18,08 (.712)	0,353	16,26 (.640)	18,47 (.727)	0,533	16,61 (.654)	19,51 (.768)	0,789
14,01 (.552)	16,00 (.630)	-160	17,88 (.704)	20,12 (.792)	0,393	18,29 (.720)	20,50 (.807)	0,591	18,64 (.734)	21,54 (.848)	0,872
16,01 (.631)	18,00 (.709)	-180	19,91 (.784)	22,15 (.872)	0,433	20,32 (.800)	22,53 (.887)	0,649	20,68 (.814)	23,57 (.928)	0,955
18,01 (.710)	20,00 (.788)	-200	21,95 (.864)	24,18 (.952)	0,473	22,35 (.880)	24,56 (.967)	0,706	22,71 (.894)	25,60 (1.008)	1,037

① "BK" is the minimum blind side clearance needed for satisfactory installation.

# METRIC NUT-PLATE RIVETS®

## CCMR244/NAS1097 100° REDUCED FLUSH HEAD

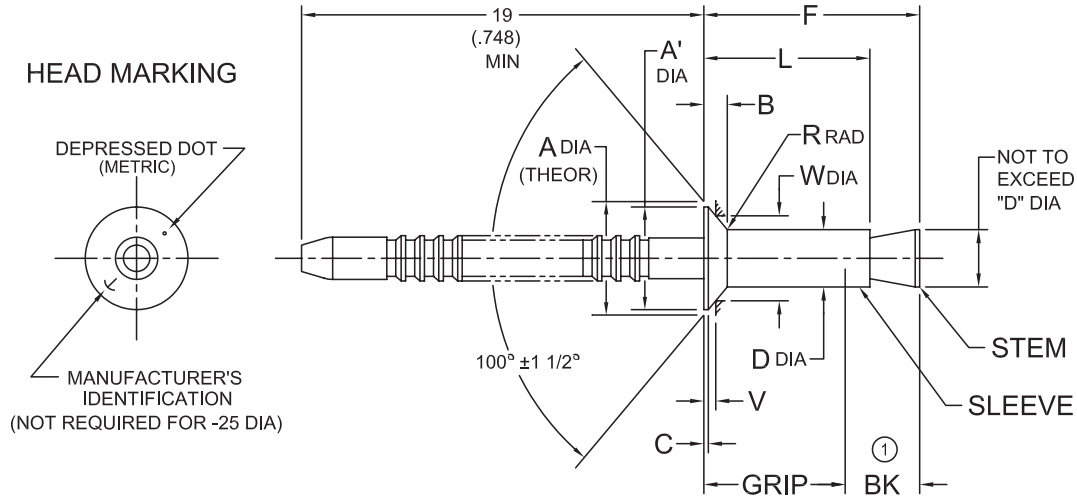

Diameter Dash No.	Nominal Diameter	A' Max	A' Actual Min	B Ref	BK <sup>①</sup>	C Min	D Coated		D Uncoated		R	V Protruding		W	Hole Size
							Max	Min	Max	Min		Coated +0,00 (.000) -0,08 (.003)	Uncoated +0,00 (.000) -0,10 (.004)		
-25	2,5 (.098)	3,90 (.154)	3,40 (.134)	0,60 (.024)	4,2 (.165)	0,05 (.0020)	2,480 (.098)	2,420 (.095)	2,480 (.098)	2,407 (.095)	0,5 (.020)	0,42 (.017)	0,42 (.017)	2,89 (.114)	2,560-2,500 mm (.101-.098")
-30	3,0 (.118)	4,70 (.185)	4,10 (.161)	0,73 (.029)	4,6 (.181)	0,06 (.0025)	2,980 (.117)	2,920 (.115)	2,980 (.117)	2,907 (.114)	0,5 (.020)	0,49 (.019)	0,49 (.019)	3,54 (.139)	3,060-3,000 mm (.120-.118")
-35	3,5 (.138)	5,50 (.217)	4,80 (.189)	0,85 (.033)	4,9 (.193)	0,07 (.0028)	3,470 (.137)	3,400 (.134)	3,470 (.137)	3,457 (.136)	0,5 (.020)	0,55 (.022)	0,55 (.022)	4,18 (.165)	3,575-3,500 mm (.141-.138")

Grip range 2 mm Range		Grip Dash Number	-25 (2.5 mm) Diameter			-30 (3.0 mm) Diameter			-35 (3.5 mm) Diameter		
Min	Max		L Max	F Max	Weight kgs per 1000 pcs	L Max	F Max	Weight kgs per 1000 pcs	L Max	F Max	Weight kgs per 1000 pcs
1,17 (.046)	2,00 (.079)	-020	3,76 (.148)	5,99 (.236)	0,087	4,19 (.165)	6,38 (.251)	0,148	4,52 (.178)	7,42 (.292)	0,230
2,01 (.079)	4,00 (.157)	-040	5,74 (.226)	7,95 (.313)	0,128	6,10 (.240)	8,3 (.328)	0,206	6,48 (.255)	9,37 (.369)	0,313
4,01 (.158)	6,00 (.236)	-060	7,72 (.304)	9,96 (.392)	0,168	8,13 (.320)	10,34 (.407)	0,263	8,48 (.344)	11,38 (.448)	0,395
6,01 (.237)	8,00 (.315)	-080	9,75 (.384)	11,99 (.472)	0,209	10,16 (.400)	12,37 (.487)	0,321	10,52 (.414)	13,41 (.528)	0,478
8,01 (.315)	10,00 (.394)	-100	11,79 (.464)	14,02 (.552)	0,249	12,19 (.480)	14,40 (.567)	0,379	12,55 (.494)	15,44 (.608)	0,561
10,01 (.394)	12,00 (.472)	-120	13,82 (.544)	16,05 (.632)	0,290	14,22 (.560)	16,43 (.647)	0,437	14,58 (.574)	17,48 (.688)	0,644
12,01 (.473)	14,00 (.551)	-140	15,85 (.624)	18,08 (.712)	0,330	16,26 (.640)	18,47 (.727)	0,494	16,61 (.654)	19,51 (.768)	0,726
14,01 (.552)	16,00 (.630)	-160	17,88 (.704)	20,12 (.792)	0,371	18,29 (.720)	20,50 (.807)	0,552	18,64 (.734)	21,54 (.848)	0,809

① "BK" is the minimum blind side clearance needed for satisfactory installation.

# CHERRY® NUT PLATE RIVETS

## HOLE PREPARATION AND TOOL SELECTION

### HOLE PREPARATION

Rivet Type	B Dimension (Min in inches)					D Dimension (Min/Max in inches)				
	-3	-4	2.5mm	3.0mm	3.5mm	-3	-4	2.5mm	3.0mm	3.5mm
CCR244	.021	.028	—	—	—	.097/.101	.129/.132	—	—	—
CCR264	.036	.042	—	—	—	.097/.101	.129/.132	—	—	—
CCR274	—	—	—	—	—	.097/.101	.129/.132	—	—	—
CCMR244	—	—	.024	.029	.033	—	—	.098/.101	.118/.120	.138/.141
CCMR264	—	—	.036	.042	.050	—	—	.098/.101	.118/.120	.138/.141
CCMR274	—	—	—	—	—	—	—	.098/.101	.118/.120	.138/.141

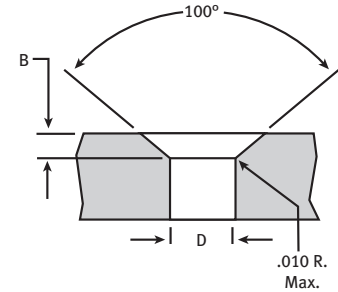

### TOOL SELECTION

Tools shown in the chart below will install the diameter rivets indicated by the shaded areas.

Tool	Pulling Head	-3(3/32"), 2.5mm	-4(1/8"), 3mm, 3.5mm
G29	INCLUDED		
G902	H902-3NPR		
	H902-4NPR		
G902-15	H9015-3C		
	H9015-4C		
G746A	H902-3NPR		
	H902-4NPR		
	H9015-3C ①		
	H9015-4C ①		
G702A	H702-3NPR ②		

① Uses 704A9 adapter, sold separately.

② Uses 728A9-104 & 728A9-3 nosepiece, included with pulling head.

# CHERRY® NUT PLATE RIVETS

## INSTALLATION TOOLING

### G29 HAND RIVETER

The Cherry G29 Hand Riveter is designed as an efficient, compact, lightweight tool for installing Cherry Nut-plate Rivets where access or power limitations prevent the use of power tools. It comes equipped with a 728A9-3 nosepiece for installing 3/32" rivets and a 728A9-104 nosepiece for installing 1/8 rivets. Overall length of the G29 is 9 1/4", and weighs just 13 oz. The pulling head is an integral part of the tool.

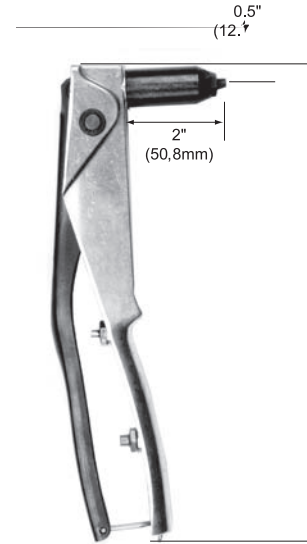

### G902 POWER RIVETER

The Cherry G902 is a pneumatic tool designed specifically for the most efficient installation of Cherry Nut-plate Rivets. It weighs just over 2 lbs. and can be operated in any position with one hand. It has a 3/4" stroke and a rated pull load of 550 lbs. on 90psi and 730 lbs. on 120psi air pressure at the air inlet. Stems feed through this tool system.

Pulling heads are not furnished with this riveter and must be ordered separately.

### G902-15 POWER RIVETER

The Cherry G902-15 is a pneumatic tool designed specifically for the most efficient installation of Cherry Nut-plate Rivets. It weighs just over 2 lbs. and can be operated in any position with one hand. It has a 3/4" stroke and a rated pull load of 550 lbs. on 90psi and 730 lbs. on 120psi air pressure at the air inlet. Stems are side ejected with this tool system.

Pulling heads are not furnished with this riveter and must be ordered separately.

# CHERRY® NUT PLATE RIVETS

## PULLING HEADS



### H9015 SERIES PULLING HEADS

Flush style pulling heads will install both universal and countersunk rivets. These pulling heads fit directly onto Cherry G902-15 riveters. Adapters are available for other Cherry power riveters.

Rivet Diameter		Pulling Head No.
Inches	Metric	
-3 (3/32")	2,5mm	H9015-3C
-4 (1/8")	3,0mm 3,5mm	H9015-4C



### H902 SERIES PULLING HEADS

These pulling heads fit directly onto Cherry G902 and G746A Power Riveters.

Rivet Diameter		Pulling Head No.
Inches	Metric	
-3 (3/32")	2,5mm	H902-3NPR
-4 (1/8")	3,0mm 3,5mm	H902-4NPR



### H702-3NPR PULLING HEAD

The H702-3NPR pulling head fits directly on the G702A power riveter. It comes equipped with a 728A9-3 nosepiece for installing 3/32" rivets and a 728A9-104 nosepiece for installing 1/8" rivets.



### 728A9-3 NOSEPIECE

For installing 3/32" and 2,5mm rivets. Fits H702-3NPR pulling head and G29 riveter.



### 728A9-104 NOSEPIECE

For installing 1/8" 3,0mm and 3,5mm rivets. Fits H702-3NPR pulling head and G29 riveter.



