

## D.C. Hydraulic Power Systems

Compact designs, integrated and manifold valve circuits

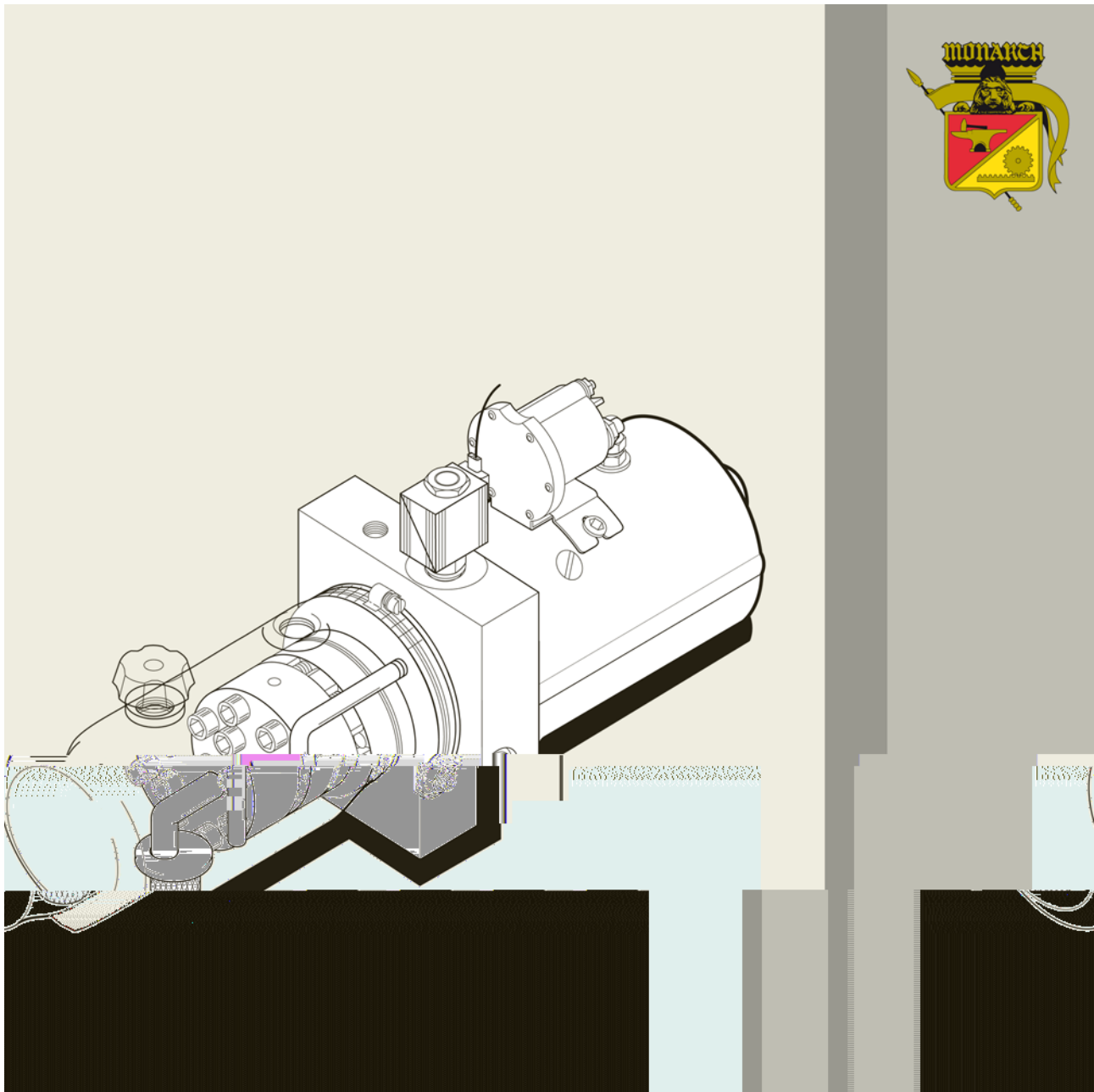

**motion and progress**



# Contents

Page

1	General information .....	7
1.1	Introduction .....	7
1.2	Mission Statement .....	7
1.3	Quality Policy .....	7
1.4	Bucher Hydraulics Value Statement .....	7
1.5	Prototype Policy .....	7
1.6	Features and Benefits .....	7
<hr/>		
2	How to Use This Product Guide .....	8
2.1	M Series D.C. Power System Selection Guide .....	9
<hr/>		
3	D.C. Hydraulic Power Systems .....	11
3.1	Model M-3226 Mini System (Formerly M-255) .....	11
3.2	Model M-3326 Dyna-Jack® (Formerly M-326) .....	12
3.3	Model M-3304 Dyna-Jack® (Formerly M-304) .....	13
3.4	Model M-3504 Dyna-Jack® .....	14
3.5	Model M-3301 Dyna-Jack® (Formerly M-301) .....	15
3.6	Model M-3311 Dyna-Jack® (Formerly M-311) .....	16
3.7	Model M-3313 Dyna-Jack® (Formerly M-313) .....	17
3.8	Model M-721 Dyna-Chute® .....	18
3.9	Model M-3219 W/PCFC Mini System (Formerly M-258) .....	19
3.10	Model M-3219 Mini System (Formerly M-259) .....	20
3.11	Model M-3319 Dyna-Jack® (Formerly M-319) .....	21
3.12	Model M-3519 Dyna-Jack® .....	22
3.13	Model M-3519-HF Dyna-Jack® .....	23
3.14	Model M-3505 Dyna-Jack® (Formerly M-3515) .....	24
3.15	Model M-3506 Dyna-Jack® (Formerly M-3516) .....	25
3.16	Model M-3314 Dyna-Jack® (Formerly M-314) .....	26
3.17	Model M-3303 Dyna-Jack® (Formerly M-303) .....	27
3.18	Model M-719 Dyna-Jack® .....	28
3.19	Model M-3310 Dyna-Jack® (Formerly M-310) .....	29
3.20	Model M-3541 Dyna-Jack® .....	30
3.21	Model M-3542 Dyna-Jack® .....	31
3.22	Model M-3534 Dyna-Jack® .....	32
3.23	Model M-3547 Dyna-Jack® .....	33
3.24	Model M-3551 Dyna-Jack® .....	34
3.25	Model M-3551-HF Dyna-Jack® (High Flow) .....	35
3.26	Model M-3554 Dyna-Jack® .....	36
3.27	Model M-3552 Dyna-Jack® .....	37
3.28	Model M-642 Dyna Ramic® .....	38

3.29	Model M-500-4W/3W Dyna-Jack ®	39
3.30	Model M-683 Dyna Ramic ®	40
3.31	Model M-3528 Dyna-Jack ®	41
3.32	Model M-3529 Dyna-Jack ®	42
3.33	Model M-3593 Dyna-Jack ®	43
3.34	Modular Power Units	44
3.35	How to Order Your Modular Power Unit	47
3.36	S-326 Pump/Motor Units	48
3.37	Dimensional Information for S-326 Pump/Motor Units	49
3.38	SAE AA Pump Data	50
3.39	SAE A Pump Data	50
3.40	How to Order S-326 Pump/Motor Units	50
3.41	M Series D.C. Pump Data	51
3.42	Performance Curve AA	52
3.43	Performance Curve AB	52
3.44	Performance Curve AC	53
3.45	Performance Curve AD	53
3.46	Performance Curve AE	54
3.47	Performance Curve AF	54
3.48	Performance Curve AG	55
3.49	Performance Curve AH	55
3.50	Performance Curve AI	56
3.51	Performance Curve AJ	56
3.52	Performance Curve AK	57
<hr/>		
4	Biorotational Hydraulic Power Systems	58
4.1	Biorotational i - Pump	58
4.2	Model M-3504	59
4.3	Model M-3530	60
4.4	Model M-3547	61
<hr/>		
5	Dim. Information for Standard D.C. Motors with Performance Curves	62
5.1	M Series D.C. Motor Information	62
5.2	08053 D.C. Motor Information	63
5.3	08111 D.C. Motor Information	64
5.4	08058 D.C. Motor Information	65
5.5	18442 D.C. Motor Information	66
5.6	08196 D.C. Motor Information (Replaces 08100)	67
5.7	08050 D.C. Motor Information	68
5.8	08163 D.C. Motor Information	69
5.9	08164 D.C. Motor Information	70
5.10	08045 D.C. Motor Information	71

5.11	08030 D.C. Motor Information .....	72
5.12	08004 D.C. Motor Information .....	73
5.13	08189 D.C. Motor Information .....	74
5.14	08066 D.C. Motor Information .....	75
5.15	08051 D.C. Motor Information .....	76
5.16	08120 D.C. Motor Information .....	77
5.17	08035 D.C. Motor Information .....	78
5.18	08195 D.C. Motor Information .....	79
5.19	08168 D.C. Motor Information .....	80
5.20	08055 D.C. Motor Information .....	81
5.21	08040 D.C. Motor Information .....	82
5.22	08055 D.C. Motor Information .....	83
5.23	08174 D.C. Motor Information .....	84
5.24	Motor Thermal Performance Data .....	85
<hr/>		
6	M Series Reservoirs .....	86
6.1	M-Series Reservoirs Steel .....	86
6.2	M-Series Reservoirs Poly .....	89
6.3	M-Series Reservoirs Poly 5.5"x6.5" Top .....	90
6.4	M-Series Reservoirs Poly 6" Centered .....	91
6.5	M-Series Reservoirs Poly 6" Offset .....	92
6.6	M-Series Reservoirs Poly 6.75"x6.75" .....	93
6.7	M-Series Reservoirs Poly 9"x10" .....	94
6.8	Reservoirs for Mini Units Poly 3.5"x3.5" MINI .....	95
6.9	Reservoirs for Mini Units Poly 3.5"x5.38" MINI .....	96
6.10	Valves for DC Systems .....	97
6.11	Motor Start Switches for D.C. Power Systems .....	99
6.12	Control Boxes .....	100
6.13	Mounting Brackets .....	101
6.14	Popular Accessories For DC Power Systems .....	102
6.15	Monarch Hand Pumps .....	103
6.16	Standard Hand Pumps .....	103
6.17	High Pressure - Low Displacement Hand Pump .....	104
6.18	High Pressure - Heavy Duty Hand Pump .....	105
6.19	Heavy Duty Remote Hand Pump .....	106
6.20	Model H-100 Series Hand Pumps With Reservoirs .....	106
6.21	Battery Cables .....	107
6.22	Limited 1 Year Warranty .....	108



# 1 General information

## 1.1 Introduction

This catalogue illustrates the technical specifications for Bucher Hydraulic's D.C. range of Hydraulic Power Units. Designed for compactness and durability, millions of M Series systems have been sold worldwide for actuating mobile, material handling, transport, construction, defense, access, machine tool, ergonomic, and other labor saving devices.

The Bucher Hydraulic name is synonymous with precise and cost efficient designs, robust construction and rapid backup service. For over 150 years the company continues to strive for your confidence by offering personal, reliable service and "Quality Machinery Since 1856" to customers in over 37 countries.

## 1.2 Mission Statement

Bucher Hydraulics designs, manufactures and delivers innovative fluid power solutions and provides unparalleled support for its customers.

## 1.3 Quality Policy

Bucher Hydraulics will provide its customers with products and services of continually improving quality to the mutual satisfaction of all parties.

## 1.4 Bucher Hydraulics Value Statement

- Bucher Hydraulics will be honest, moral and ethical.
- Bucher Hydraulics will accept responsibility for its actions.
- Bucher Hydraulics will treat people with equality.
- Bucher Hydraulics will make a profit.

## 1.5 Prototype Policy

We invite you to try our prototype program for solutions to Your special hydraulic needs.

While Bucher Hydraulics offers a broad line of hydraulic systems and components, it is impossible to anticipate the needs of every customer, especially those developing new products. Our unique prototype program allows us to respond to your specific needs when an existing catalogue model" does not fit your application.

To participate in this program, simply submit a print, schematic or sketch of the hydraulic power pack that you need along with a purchase order. We will review the system requirements with you and then manufacture the system that we believe will satisfy your objectives. The unit will be invoiced at an agreed upon price an marked Prototype.

You have 90 days free use of this product for testing an evaluation from the date of invoice. At the end of this period you can (1) extend the testing and evaluation period for an additional 90 days or (2) purchase the unit as invoiced (and order more if needed) or (3) return the unit via prepaid transportation for full credit

There is no risk to you. Just the opportunity to solve your hydraulic problem with the performance and quality of Bucher Hydraulics



### ATTENTION!

- Always wear eye protection and protective clothing.
- Remove jewelry and objects that might conduct electricity while working on power units.
- Hydraulic fluid does pose a fire hazard, can cause burning or skin irritation if not properly handled.
- Fluid under pressure can pierce the skin and enter the bloodstream causing death or serious injury.
- Devices being operated by the hydraulic system should be immobilized so they cannot move and cause injury while being inspected or repaired.  
Disconnect from electrical source.
- Prior to performing any maintenance make sure the equipment is turned off and that any stored energy, for example pressure, is released. Also, extended equipment or cylinders should be lowered and mechanically locked as required.
- Bucher Hydraulics is not responsible for misuse or misapplication of product. If you have any questions about application, please contact local dealer.
- Fluids should be contained and disposed of properly.

## 1.6 Features and Benefits

Standard M-3200, M-3300 and M3500 series:

- Wide selection of power unit sizes and performance to satisfy most O.E.M. applications.
- Hardcoated pump end plates for unmatched durability in demanding environments and severe duty applications
- Bucher Hydraulics prototype program: Purchase or return within 90 days of shipment.
- 1 year limited warranty on pump & motor.
- Bucher Hydraulics personal customer service.
- 24 Hour shipment on most parts orders
- Over five million M pumps sold

### Options

- Custom motors, valves, reservoirs, control stations and circuits.
- Valve manifolds - remote of mounted directly to the power unit.

## 2 How to Use This Product Guide

- Select the Circuit that will satisfy your design objectives (refer to page 9/110). Contact the factory if you require assistance.
- Select the Model that will provide the desired Valve Activation (Manual or Solenoid) listed in the Power System Selection Guide (refer to page 9/110).
- Follow the "How To Order Your M-3200, M-3300, or S-326 Power System" provided after each, model description. Only the most popular combinations are listed for the particular system. Custom configurations are available and should be discussed with the factory.
- The operating and design characteristics for all of the basic components are listed on pages 51-103 of this guide.

Select Pump on Page 51

Select Motor on Page 62

Select Reservoir on Page 86-96

Select Valve(s) on Page 97

Select Motor Starting Switch on Page 99

Select Control Boxes on Page 100

Select Mounting Bracket on Page 101

Select Popular Accessories on Page 102

Select Hand Pump on Page 103

- Nominal Dimensions are shown for all basic components. Dimensions may be found for your particular system by deleting the component shown on the unit drawing and adding the dimension for the same item you have selected. Note: Dimensions may vary slightly and should be confirmed by the factory if unit is to be installed in space with minimum clearance.
- When selecting a reservoir, consideration should be given to dissipating heat, separating air from the oil, and settling out contamination in the oil. There must always be a reserve of oil in the reservoir when all cylinders are fully extended and not overflow when all cylinders are fully retracted. Monarch reservoirs must be vented. Contact the factory for proper reservoir sizing for your application.
- Motor Thermal Data. Determine that the motor selected is thermally suited for the "run time" required by consulting the Motor Thermal Performance Data located on page 85

Note: Not all options are available on every D.C. System. Contact the Factory for assistance.

## 2.1 M Series D.C. Power System Selection Guide

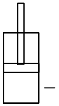
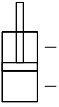
Circuit	Description	Model	Page
	Pump + Motor	M-3226	11
		M-3326	12
		S-326	49
	Pump + Motor + Reservoir	M-3304	13
		M-3504	14
		M-3598*	
		M-3204	59
Operates Single Acting Cylinder			
	Pump + Motor + Reservoir + Manual Valve	M-3301	15
		M-3311	16
		M-3313	17
		M-721	18
		M-3513*	
	Pump + Motor + Reservoir + Solenoid Valve	M-3219-w/PCFC	19
		M-3219	20
		M-3319	21
		M-3519*	22
		M-3519-HF	23
		M-3314	26
		M-3303	27
		M-719	28
	Operates Double Acting Cylinder		
	Pump + Motor + Reservoir + Manual Valve	M-3310	29
	Pump + Motor + Reservoir + Solenoid Valve	M-3551	34
		M-3551-HF	35
		M-642	38
		M-3515*	24
		M-3516	25
		M-3541	30
		M-3542	31

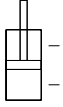
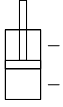
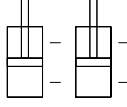
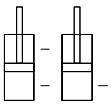
Circuit	Description	Model	Page
	Pump + Motor + Reservoir + Solenoid Valve	M-3534	32
		M-3552*	37
		M-3554	36
		M-3530*	44
		M-3547*	33
	Pump + Motor + Reservoir Bi Rotational Units	M-3504	59
		M-3530	60
		M-3547	61
Operates 2 Double Acting Cylinder			
	Pump + Motor + Reservoir + Solenoid Valves	M-3528*	41
		M-3529*	42
Operates 1 Double Acting and 1 Single Acting Cylinder			
	Pump + Motor + Reservoir + Manual Valves	M-500-4W/3W	39
	Pump + Motor + Reservoir + Solenoid Valves	M-683	40
		M-3593*	43

\* = Modular

Many other circuits are available. Please contact Monarch direct so we can design a special circuit for your requirements.

### 3 D.C. Hydraulic Power Systems

#### 3.1 Model M-3226 Mini System (Formerly M-255)

**Description**

- Pump Motor Unit
- Check Valve
- Externally Adjustable Relief Valve
- .375 Inch NPT Suction
- 7/16-20 SAE Outlet Port

**Schematic**

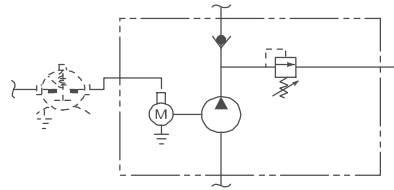

**Popular Options**

- Motor Start Solenoid and Cable

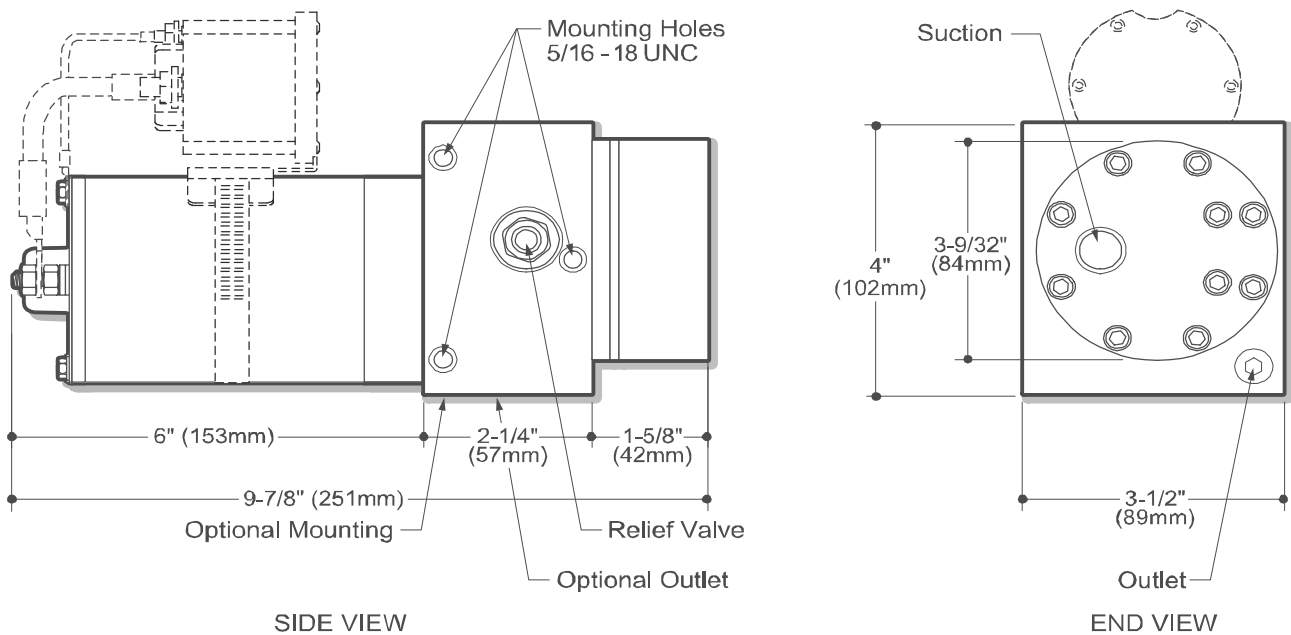

**How to Order Your M-3226 Mini System**

Comprehensive information may be found on the page referenced below each selection category.

Shown as standard with:

Pump	Motor	Voltage	Motor Start Switch	Accessories
i-pump (req'd.)	08053	12		
Ref. Page 51	Ref. Page 62		Ref. Page 99	Ref. Page 102

### 3.2 Model M-3326 Dyna-Jack<sup>®</sup> (Formerly M-326)

#### Description

- Pump Motor Unit
- Check Valve
- Externally Adjustable Relief Valve
- .375 Inch NPT Suction
- #6 SAE Outlet
- .125 Inch NPT Relief Valve Return Port

#### Popular Options

- Suction and Outlet on Pump End Plate
- Motor Start Solenoid and Bus Bar

#### Schematic

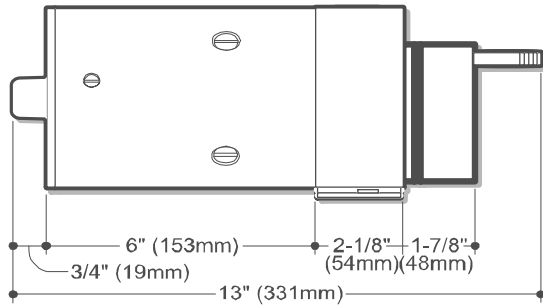
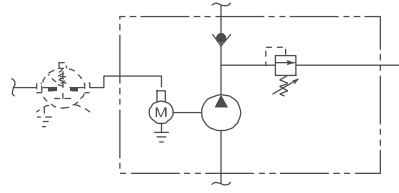

SIDE VIEW

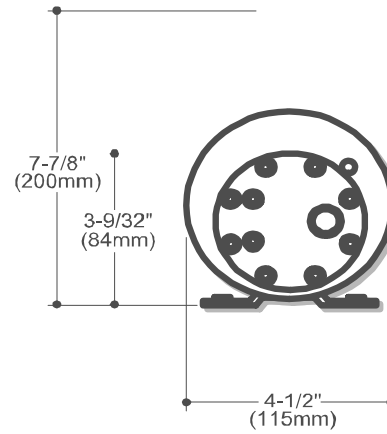

END VIEW

### 3.3 Model M-3304 Dyna-Jack<sup>®</sup> (Formerly M-304)

#### Description

- Pump / Motor / Reservoir / Unit
- Check Valve
- Externally Adjustable Relief Valve
- #6 SAE Outlet
- .250 NPT Return
- Horizontal Mounting Standard

#### Popular Options

- Vertical Mounting / Motor Up

#### Schematic

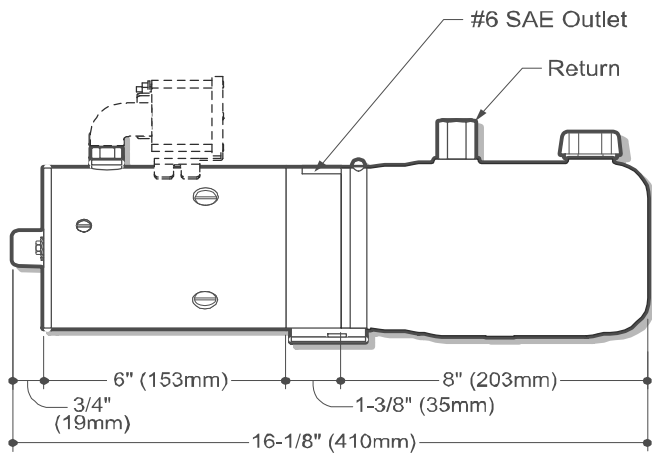
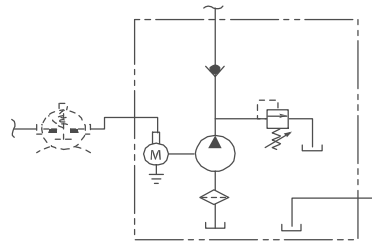

SIDE VIEW

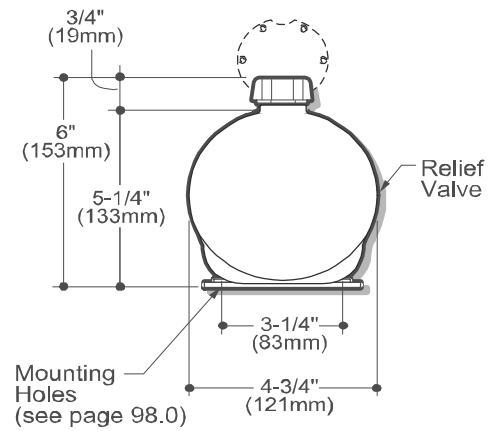

END VIEW

#### How to Order Your M-3304 Dyna-Jack<sup>®</sup>

Comprehensive information may be found on the page referenced below each selection category.

Shown as standard with:

Pump	Motor	Voltage	Reservoir (Length)	Motor Start Switch	Mounting Bracket	Mounting Position	Accessories
	08111	12	06102		04560	Horizontal	
Ref. Page 51	Ref. Page 62		Ref. Page 86-96	Ref. Page 99	Ref. Page 101		Ref. Page 102

### 3.4 Model M-3504 Dyna-Jack®

**Description**

- Pump / Motor / Reservoir / Unit
- Check Valve
- Externally Adjustable Relief Valve
- #6 SAE Outlet
- #6 SAE Return
- Horizontal Mounting Standard

**Popular Options**

- Vertical Mounting / Motor Up

**Schematic**

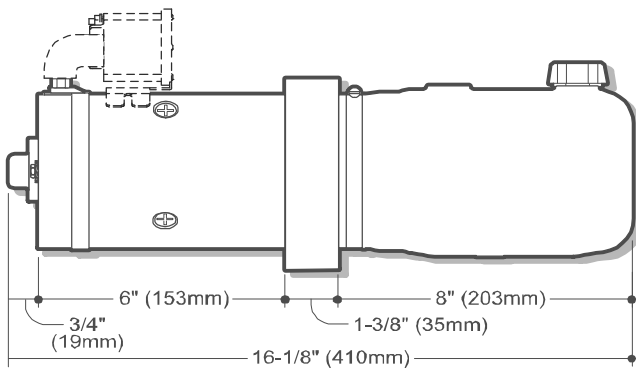
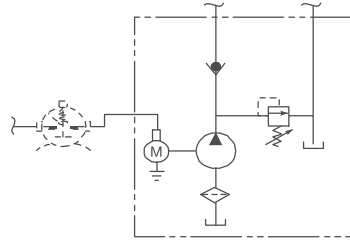

SIDE VIEW

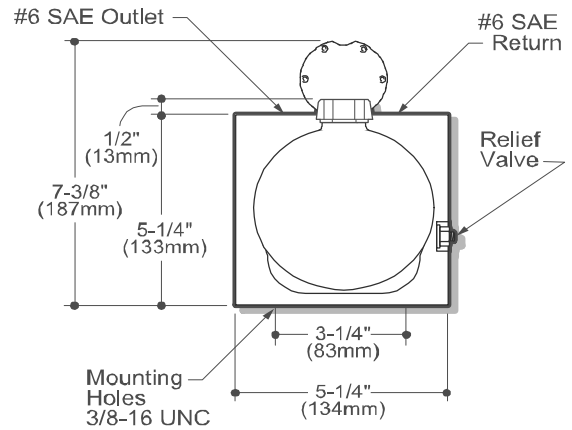

END VIEW

### How to Order Your M-3504 Dyna-Jack®

Comprehensive information may be found on the page referenced below each selection category.

Shown as standard with:

Pump	Motor	Voltage	Reservoir (Length)	Motor Start Switch	Mounting Position	Accessories
	08111	12	06102		Horizontal	
Ref. Page 51	Ref. Page 62		Ref. Page 86-96	Ref. Page 99		Ref. Page 102

### 3.5 Model M-3301 Dyna-Jack® (Formerly M-301)

#### Description

- Pump / Motor / Reservoir / Unit
- Manually Operated 2-Way/2-Position Normally Closed Valve With Motor Start Switch
- Check Valve
- Externally Adjustable Relief Valve
- #4 SAE Outlet
- Horizontal Mounting Standard

#### Schematic

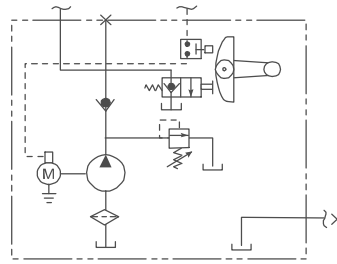

#### Popular Options

- Vertical Mounting / Motor Up

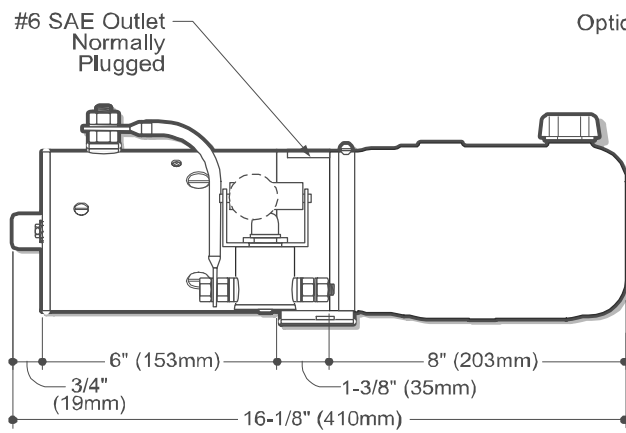

SIDE VIEW

Optional Eye-Bolt

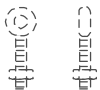

Optional Handle Location

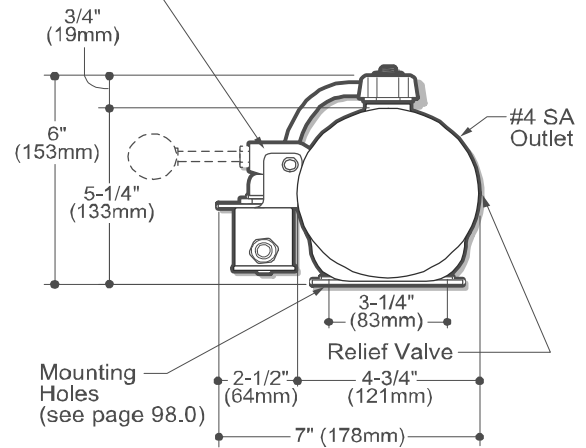

END VIEW

#### How to Order Your M-3301 Dyna-Jack®

Comprehensive information may be found on the page referenced below each selection category.

Shown as standard with:

Pump	Motor	Voltage	Reservoir (Length)	Mounting Bracket	Mounting Position	Accessories
	08111	12	06102	04560	Horizontal	
Ref. Page 51	Ref. Page 62		Ref. Page 86-96	Ref. Page 101		Ref. Page 102

### 3.6 Model M-3311 Dyna-Jack<sup>®</sup> (Formerly M-311)

#### Description

- Pump / Motor / Reservoir / Valve
- Manually Operated 2-Way/2-Position Normally Closed Valve With Motor Start Switch
- Metered Spool for Fine Control of Lowering Speed
- Check Valve
- Externally Adjustable Relief Valve
- #4 SAE Outlet
- Horizontal Mounting Standard

#### Popular Options

- Non-Metered Lowering Spool
- Vertical Mounting / Motor Up

#### Schematic

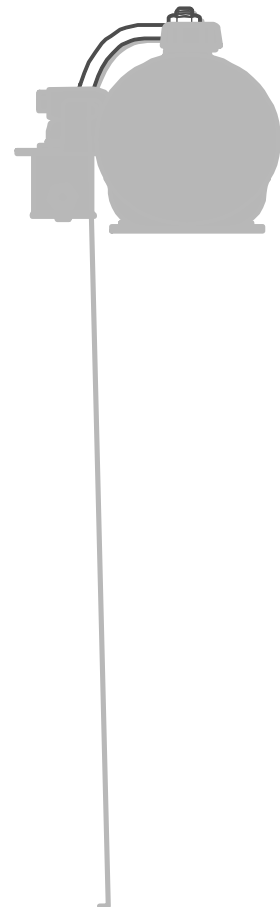
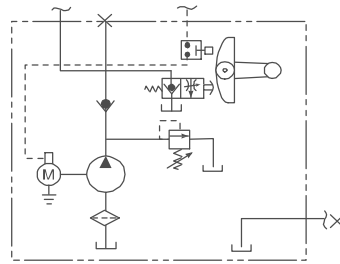

### 3.7 Model M-3313 Dyna-Jack<sup>®</sup> (Formerly M-313)

#### Description

- Pump / Motor / Reservoir / Valve
- Manually Operated 2-Way/2-Position Normally Closed Valve With Motor Start Switch. Valve Handle Travel Is Inline With Motor
- Check Valve
- Externally Adjustable Relief Valve
- #6 SAE Outlet
- Horizontal Mounting Standard

#### Schematic

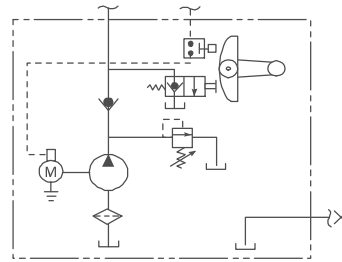

#### Popular Options

- Metered Lowering Valve Housing For Fine Control of Lowering Speed
- .250 Inch NPT Outlet
- Vertical Mounting / Motor Up

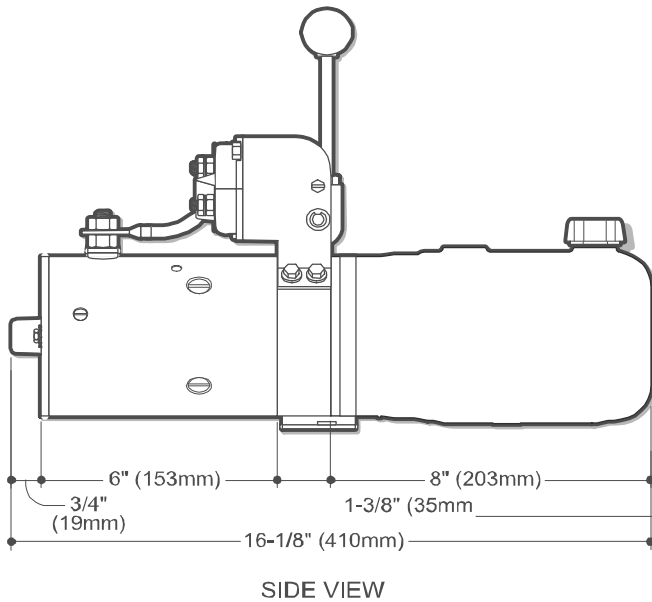

### 3.8 Model M-721 Dyna-Chute®

**Description**

- Pump / Motor / Reservoir / Valve
- Manually Operated 2-Way/2-Position Normally Closed Valve With Motor Start Switch
- Externally Adjustable Relief Valve
- .250 Inch NPT and .375 Inch NPT Outlets
- Vertical Mounting Only
- Includes Protective Steel Cover

**Schematic**

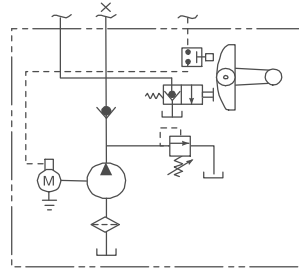

**Typical Application:**

- Controls Discharge Chute on Cement Delivery Truck

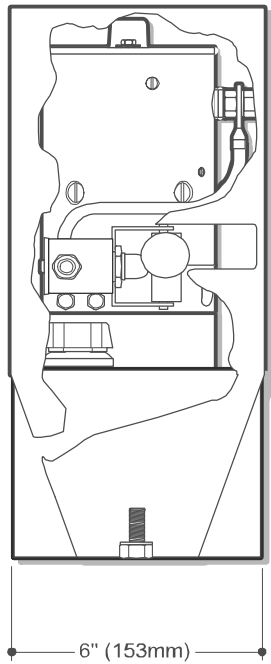

SIDE VIEW

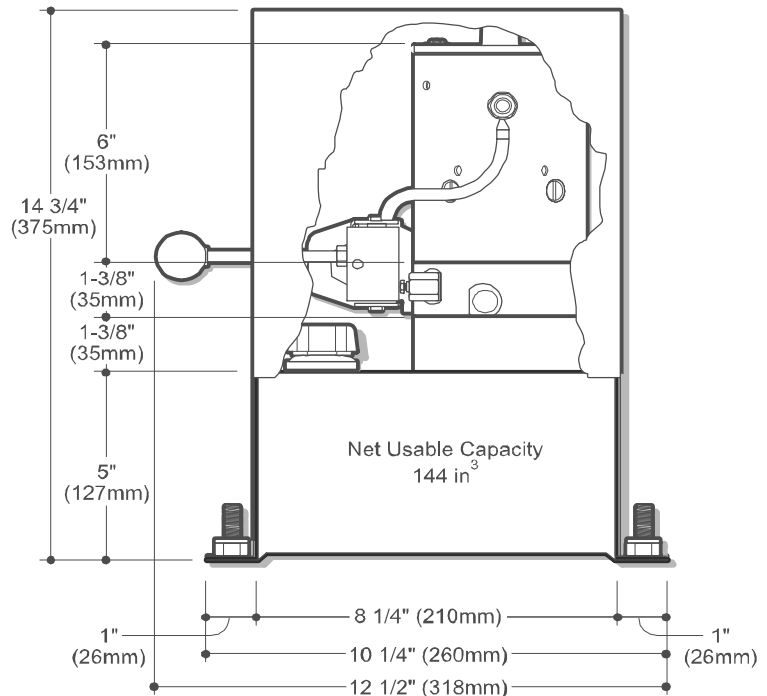

END VIEW

**How to Order Your M-721 Dyna-Chute®**

Comprehensive information may be found on the page referenced below each selection category.

Shown as standard with:

Pump	Motor	Voltage	Mounting Position	Accessories
12171-270	08111	12	Vertical	
Ref. Page 51	Ref. Page 62			Ref. Page 102

### 3.9 Model M-3219 W/PCFC Mini System (Formerly M-258)

#### Description

- Pump / Motor / Reservoir / Valve
- 2-Way/2-Position Normally Closed Solenoid Operated Lowering Valve
- Cartridge Style Pressure Compensated Lowering Valve
- Externally Adjustable Relief Valve
- Outlet Port Options:  
Check Valve Port: 7/16-20 SAE O-Ring or  
Face Port: 7/16-20 SAE O-Ring
- Horizontal Mounting Standard

#### Schematic

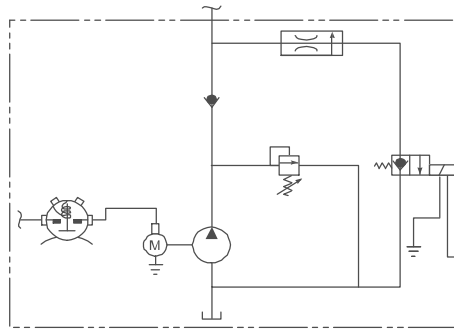

#### Popular Feature:

- Solenoid Lowering Valve is Recessed Into Base and Protected from Abuse

#### Popular Options

- Hand Pump Manifold Directly to Base. (Shown in Dashed Lines)
- .250 Inch NPT Outlet
- Control Box and Cord
- Vertical Mounting / Motor Up

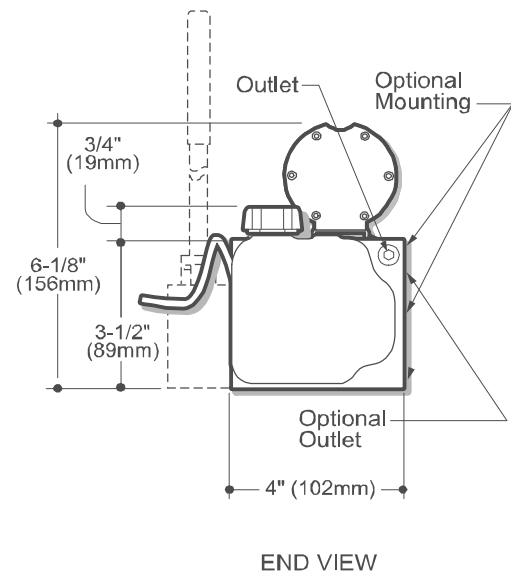
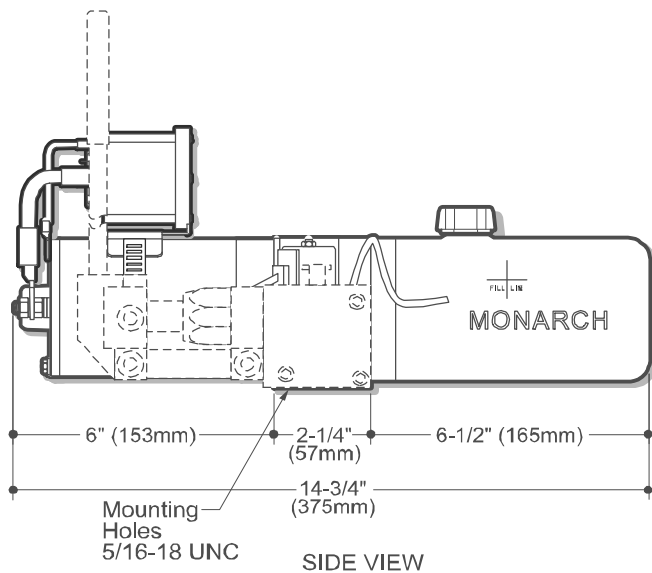

#### How to Order Your M-3219 W/PCFC Mini System

Comprehensive information may be found on the page referenced below each selection category.

Shown as standard with:

Pump	Motor	Voltage	Reservoir (Length)	Motor Start Switch	Mounting Position	Control Boxes	Optional Hand Pump	Accessories
	08053	12	06230	17757	Horizontal			
Ref. Page 51	Ref. Page 62		Ref. Page 86-96	Ref. Page 99		Ref. Page 100	Ref. Page 103	Ref. Page 102

### 3.10 Model M-3219 Mini System (Formerly M-259)

#### Description

- Pump / Motor / Reservoir / Valve
- Check Valve
- 2-Way/2-Position Normally Closed Solenoid Operated Lowering Valve
- Externally Adjustable Relief Valve
- Outlet Port Options:  
Check Valve Port: 7/16-20 SAE O-Ring or  
Face Port: 7/16-20 SAE O-Ring
- Horizontal Mounting Standard

#### Popular Feature:

- Solenoid Lowering Valve is Recessed Into Base and Protected from Abuse

#### Popular Options

- Hand Pump Manifold Directly to Base. (Shown in Dashed Lines)
- .250 Inch NPT Outlet
- Control Box and Cord
- Vertical Mounting / Motor Up

#### Schematic

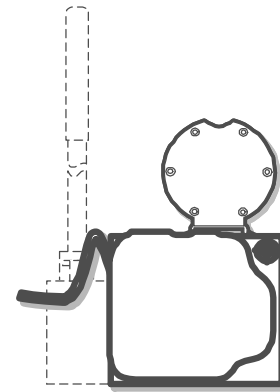
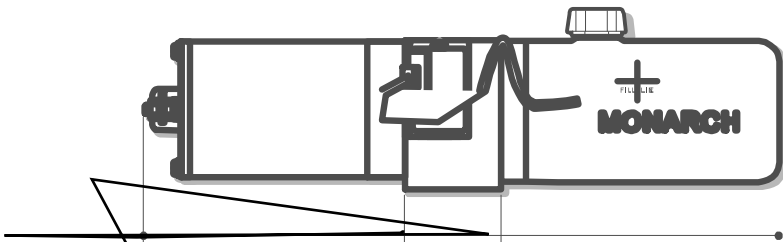
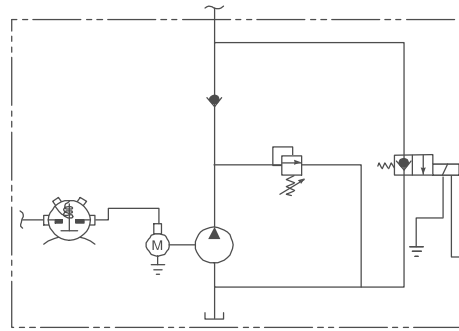

### 3.11 Model M-3319 Dyna-Jack<sup>®</sup> (Formerly M-319)

#### Description

- Pump / Motor / Reservoir / Valve
- Check Valve
- 2-Way/2-Position Normally Closed Solenoid Operated Lowering Valve
- Externally Adjustable Relief Valve
- #6 SAE Outlet
- Horizontal Mounting Standard

#### Schematic

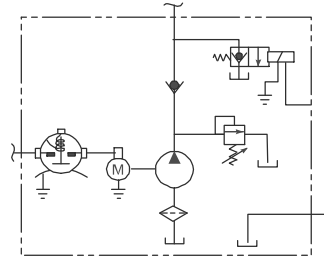

#### Popular Options

- Control Box and Cord
- Vertical Mounting / Motor Up

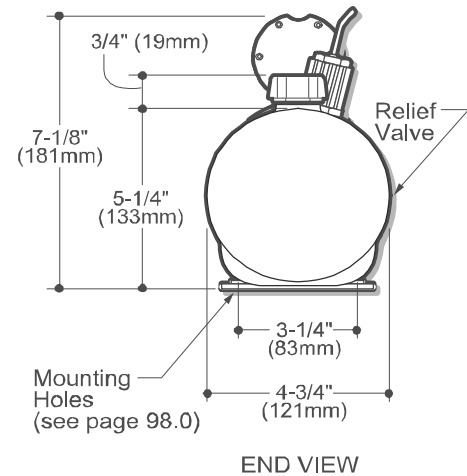
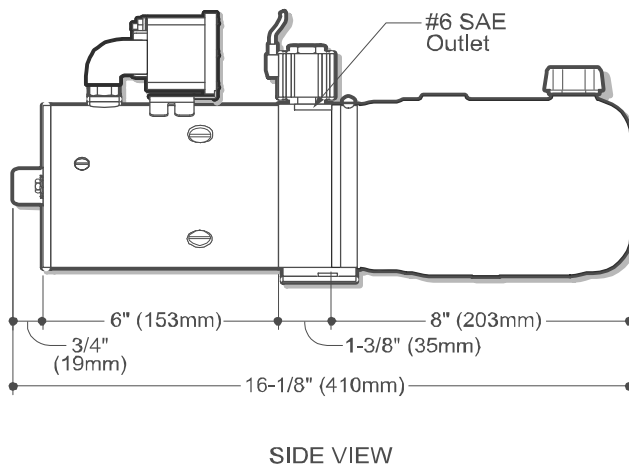

#### How to Order Your M-3319 Dyna-Jack<sup>®</sup>

Comprehensive information may be found on the page referenced below each selection category.

Shown as standard with:

Pump	Motor	Voltage	Reservoir (Length)	Motor Start Switch	Mounting Bracket	Mounting Position	Accessories	Control Boxes
	08111	12	06102	17757	04560	Horizontal		
Ref. Page 51	Ref. Page 62		Ref. Page 86-96	Ref. Page 99	Ref. Page 101		Ref. Page 102	Ref. Page 100

## Model M-3519 Dyna-Jack®

Description

1000 psi / Motor / Reservoir / Valve

Check Valve

Normally Adjustable Relief Valve

1/2-Position Normally Closed Solenoid

Bridge Valve

SAE Outlet

Horizontal Mounting Standard

Other Options

Control Box and Cord

Vertical Mounting / Motor

Pressure Compensating

Filtering Circuit\*

Manual Override

and Pump

Option

;

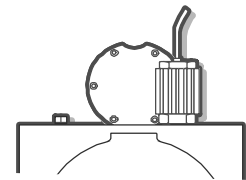

### 3.13 Model M-3519-HF Dyna-Jack®

#### Description

- Pump/Motor/Reservoir/High Flow Lowering Valve
- Pressure Drop Thru Base <100 PSI (6.9 Bar) at 8 GPM (30 LPM) With Needle Valve Completely Open for Fast Lowering Speed
- Check Valve
- Externally Adjustable Relief Valve
- 2 Way/2 Position Normally Closed Solenoid Cartridge Valve
- Horizontal Mounting Standard
- Manual Needle Valve for Adjusting Lowering Speed With Tamper Resistant Locking Cap
- #8 SAE Outlet

#### Schematic

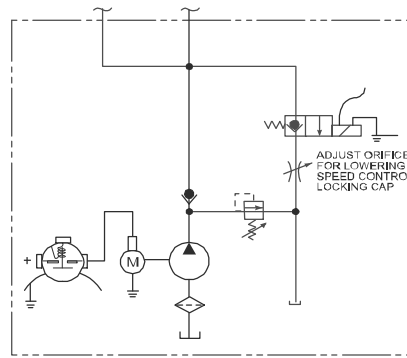

#### Popular Options

- Control Box and Cord
- Vertical Mounting / Motor Up

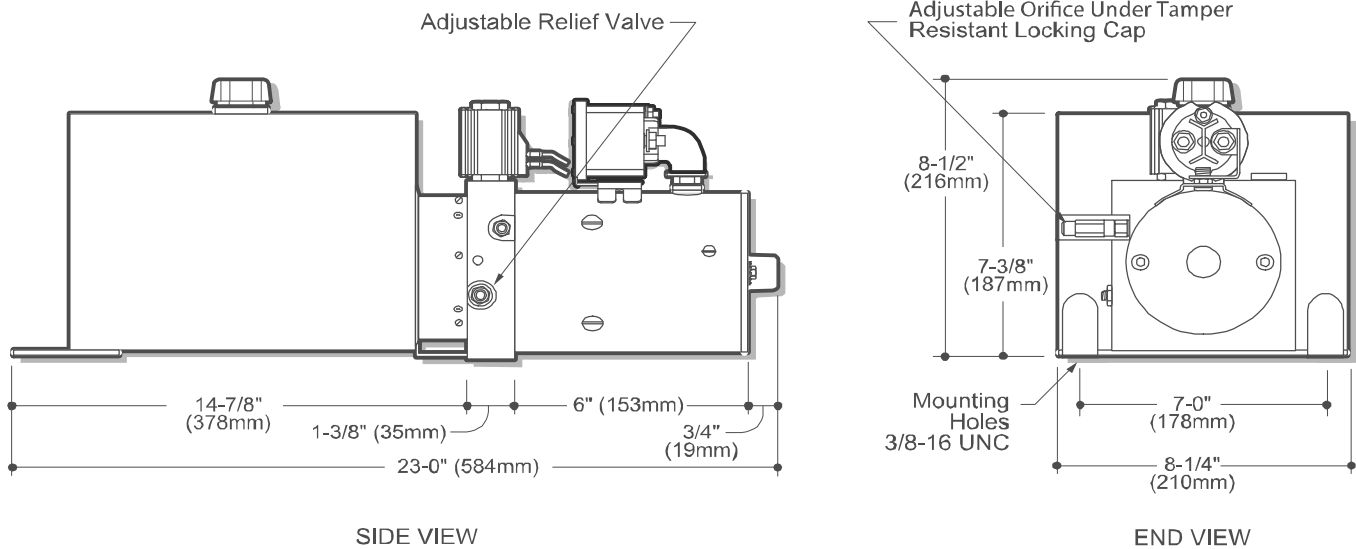

#### How to Order Your M-3519-HF Dyna-Jack®

Comprehensive information may be found on the page referenced below each selection category.

Shown as standard with:

Pump	Motor	Voltage	Reservoir (Length)	Motor Start Switch	Mounting Position	Accessories	Control Boxes
	08111	12	06328	17757	Horizontal		
Ref. Page 51	Ref. Page 62		Ref. Page 86-96	Ref. Page 99		Ref. Page 102	Ref. Page 100

### 3.14 Model M-3505 Dyna-Jack<sup>®</sup> (Formerly M-3515)

#### Description

- Pump / Motor / Reservoir / Valve
- Check Valve in "P" Port
- Externally Adjustable Relief Valve
- D03 Solenoid Valve
- #6 SAE Outlet
- Horizontal Mounting Standard

#### Popular Options

- Control Box and Cord
- Vertical Mounting / Motor Up
- Large Selection of D03/CETOP Valves and Accessories

#### Schematic

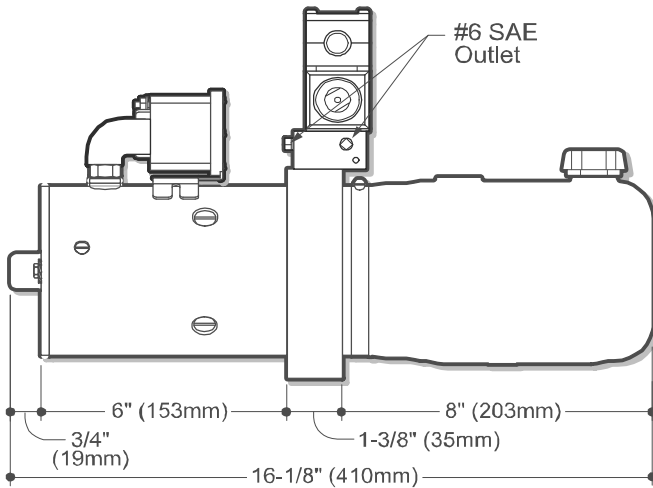
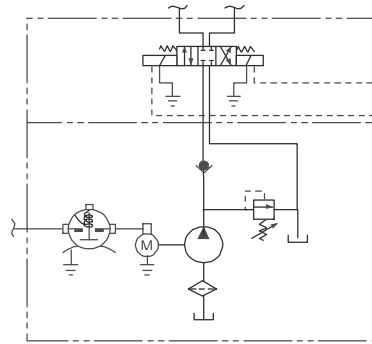

SIDE VIEW

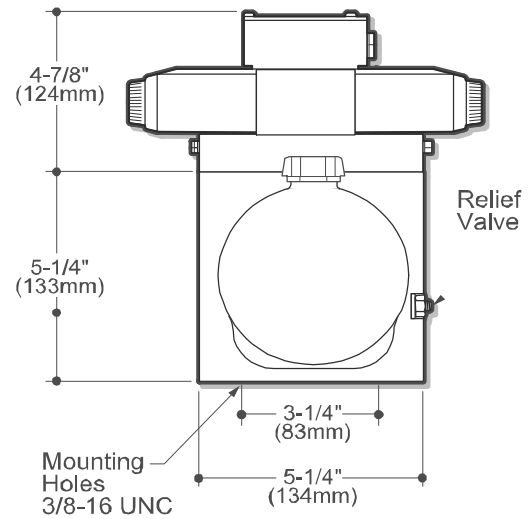

END VIEW

#### How to Order Your M-3505 Dyna-Jack<sup>®</sup>

Comprehensive information may be found on the page referenced below each selection category.

Shown as standard with:

Pump	Motor	Voltage	Reservoir (Length)	Motor Start Switch	Mounting Position	Accessories	Control Boxes
	08111	12	06102	17757	Horizontal		
Ref. Page 51	Ref. Page 62		Ref. Page 86-96	Ref. Page 99		Ref. Page 102	Ref. Page 100

### 3.15 Model M-3506 Dyna-Jack<sup>®</sup> (Formerly M-3516)

#### Description

- Pump / Motor / Reservoir
- Check Valve in "P" Port
- Externally Adjustable Relief Valve
- #6 SAE Outlet
- Horizontal Mounting Standard

#### Popular Options

- Control Box and Cord
- Vertical Mounting / Motor Up

#### Schematic

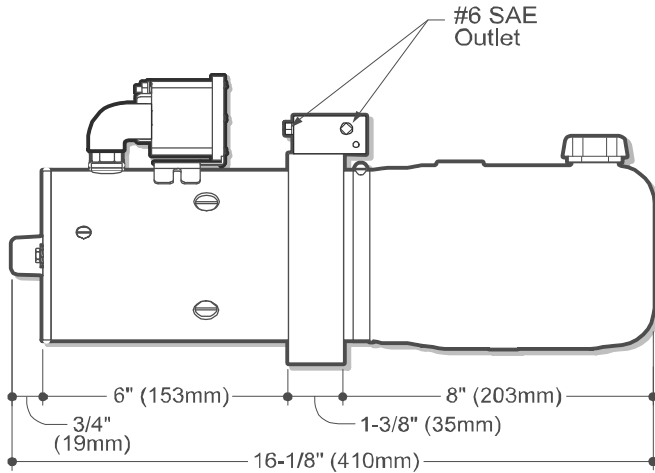
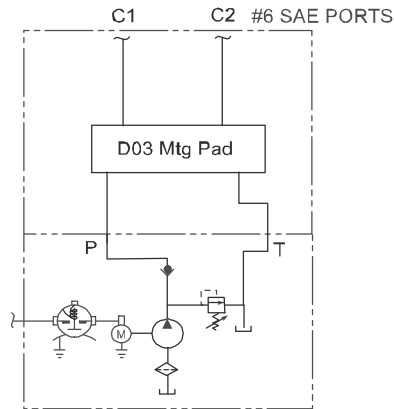

SIDE VIEW

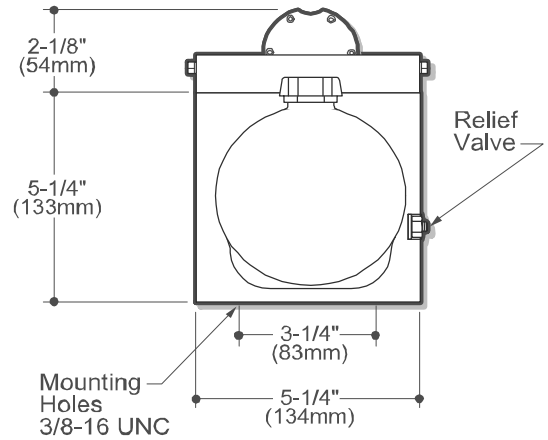

END VIEW

#### How to Order Your M-3506 Dyna-Jack<sup>®</sup>

Comprehensive information may be found on the page referenced below each selection category.

Shown as standard with:

Pump	Motor	Voltage	Reservoir (Length)	Motor Start Switch	Mounting Position	Accessories	Control Boxes
	08111	12	06102	17757	Horizontal		
Ref. Page 51	Ref. Page 62		Ref. Page 86-96	Ref. Page 99		Ref. Page 102	Ref. Page 100

### 3.16 Model M-3314 Dyna-Jack<sup>®</sup> (Formerly M-314)

#### Description

- Pump / Motor / Reservoir / Valve
- Check Valve
- 2-Way/2-Position Normally Closed Solenoid Operated Lowering Valve and Return Filter Installed in Reservoir
- Manual Override for Emergency Lowering During Power Loss
- Externally Adjustable Relief Valve
- #6 SAE Outlet
- Horizontal Mounting Standard

#### Popular Options

- Control Box and Cord
- Vertical Mounting / Motor Up

#### Schematic

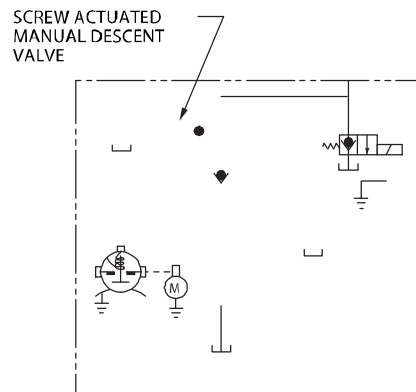

### 3.17 Model M-3303 Dyna-Jack<sup>®</sup> (Formerly M-303)

#### Description

- Pump / Motor / Reservoir / Valve
- Check Valve
- 2-Way/2-Position Normally Closed Solenoid Operated Lowering Valve and Return Filter Installed in Reservoir
- Cable
- Manual Override for Emergency Lowering During Power Loss
- Externally Adjustable Relief Valve
- #6 SAE Outlet
- Horizontal Mounting Standard

#### Popular Options

- Vertical Mounting / Motor Up
- Control Box

#### Schematic

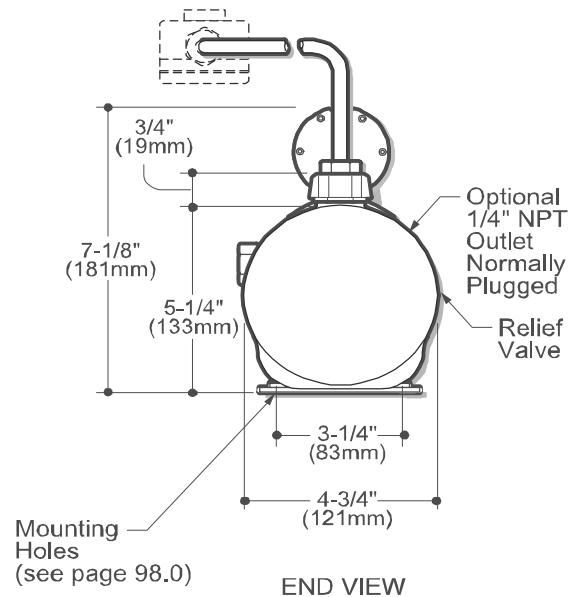
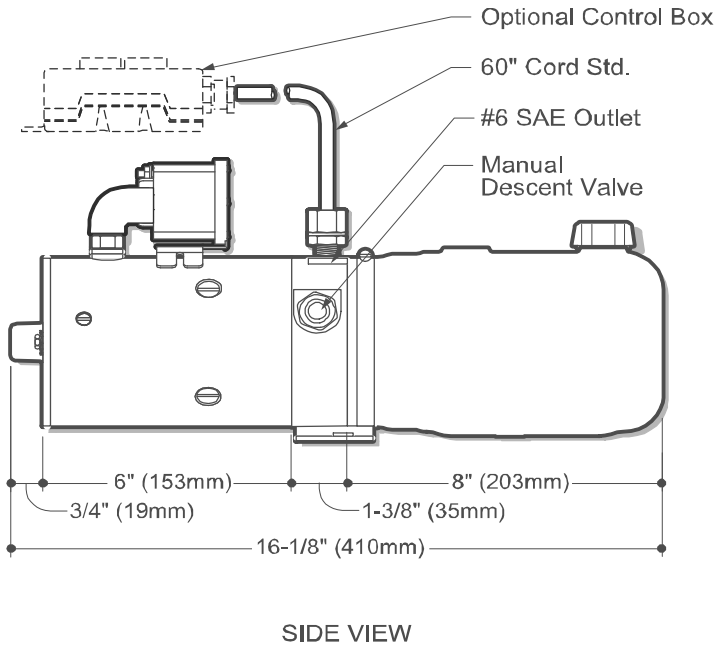
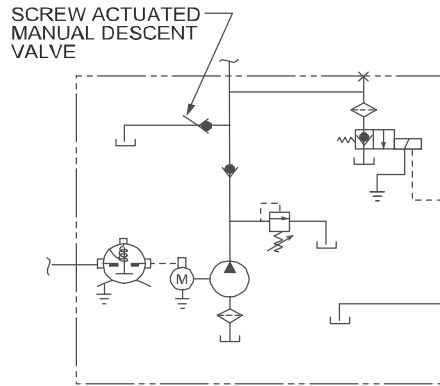

#### How to Order Your M-3303 Dyna-Jack<sup>®</sup>

Comprehensive information may be found on the page referenced below each selection category.

Shown as standard with:

Pump	Motor	Voltage	Reservoir (Length)	Cartridge Valve	Motor Start Switch	Mounting Bracket	Mounting Position	Accessories	Control Boxes
	08111	12	06102		17757	04560	Horizontal		07993
Ref. Page 51	Ref. Page 62		Ref. Page 86-96	Ref. Page 97	Ref. Page 99	Ref. Page 101		Ref. Page 102	Ref. Page 100





**BUCHER**

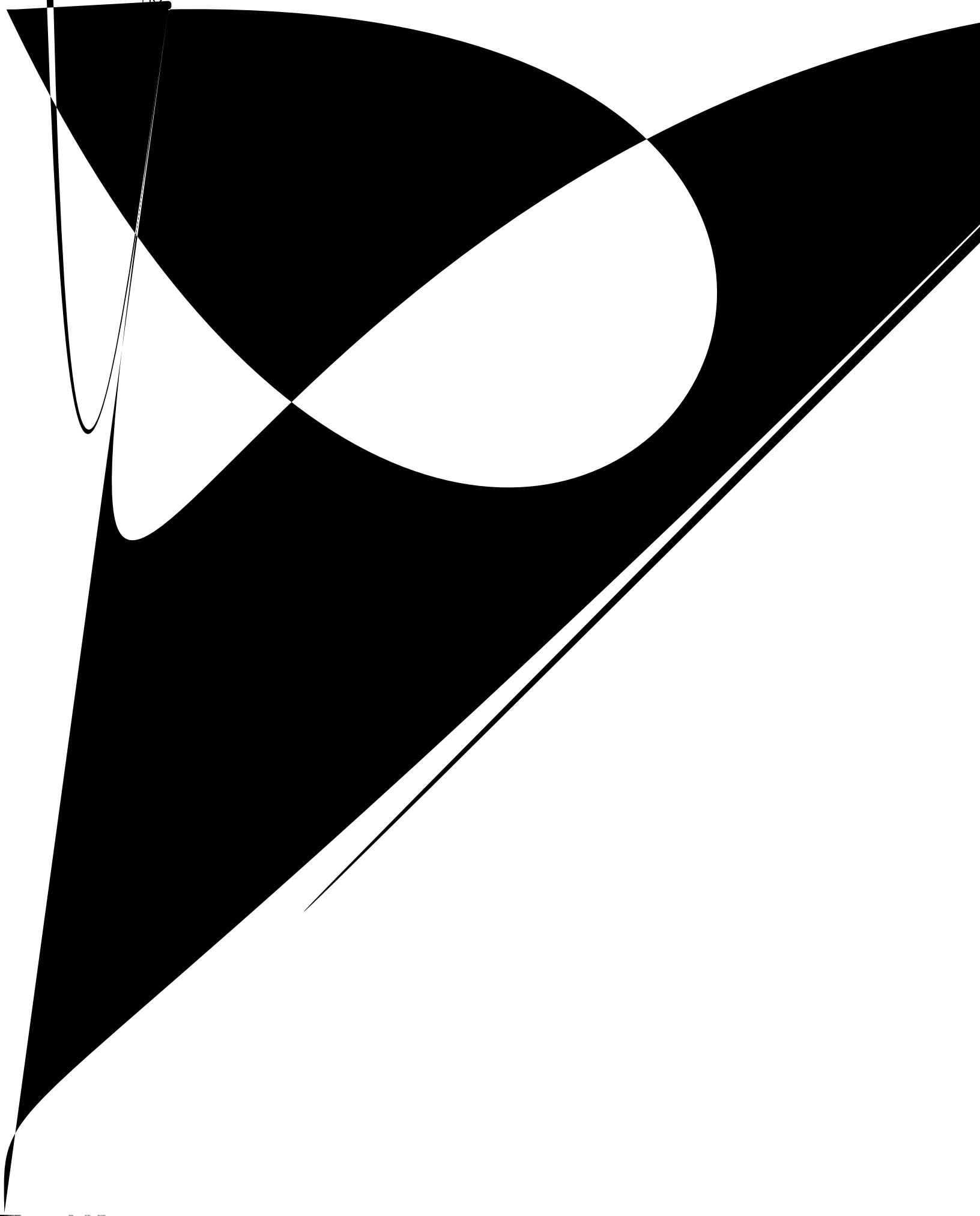

### 3.21 Model M-3542 Dyna-Jack®

#### Description

- Pump / Motor / Reservoir / Valve
- Check Valve
- Externally Adjustable Relief Valve
- 1 x 4-Way/2-Position Solenoid Cartridge Valve Located Externally. Manifoldded Directly To Unit
- C1 Port Positively Checked
- Externally Adjustable Relief Valve in C2 Port
- #6 SAE Outlet
- Horizontal Mounting Standard

#### Schematic

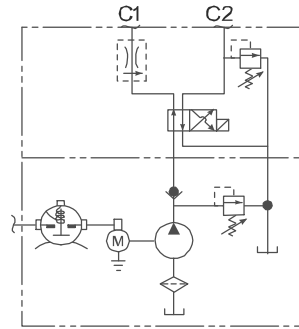

#### Popular Options

- Pressure Compensated (Cartridge Style) Flow Control In C1 Port
- Control Box and Cord
- Vertical Mounting / Motor Up

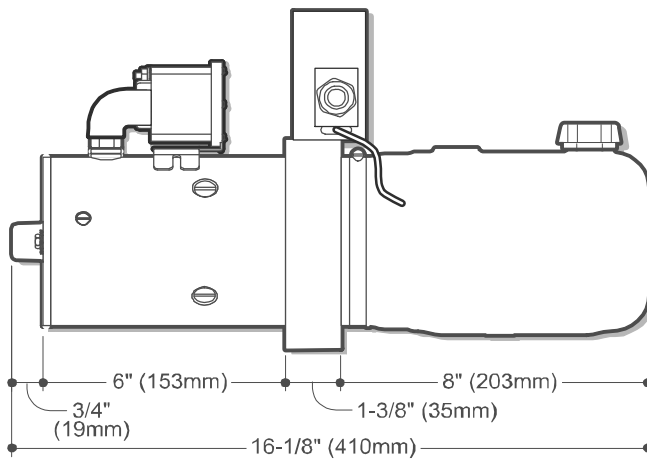

SIDE VIEW

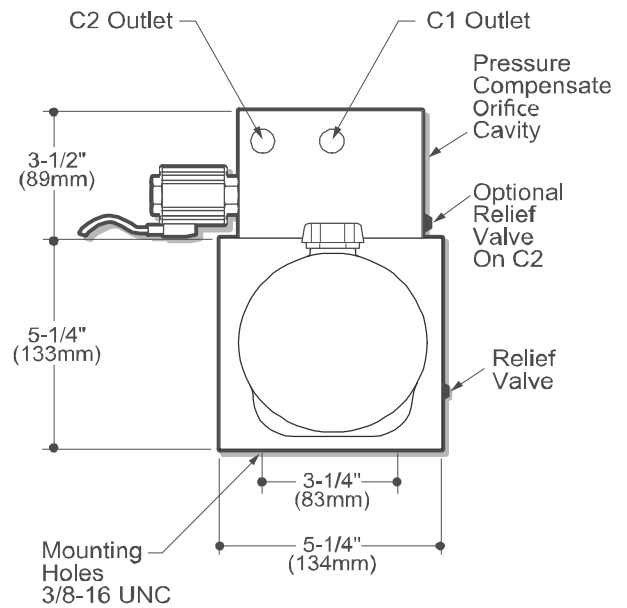

END VIEW

#### How to Order Your M-3542 Dyna-Jack®

Comprehensive information may be found on the page referenced below each selection category.

Shown as standard with:

Pump	Motor	Voltage	Reservoir (Length)	Motor Start Switch	Mounting Position	Accessories	Control Boxes
	08111	12	06102	17757	Horizontal		
Ref. Page 51	Ref. Page 62		Ref. Page 86-96	Ref. Page 99		Ref. Page 102	Ref. Page 100

**BUCHER**

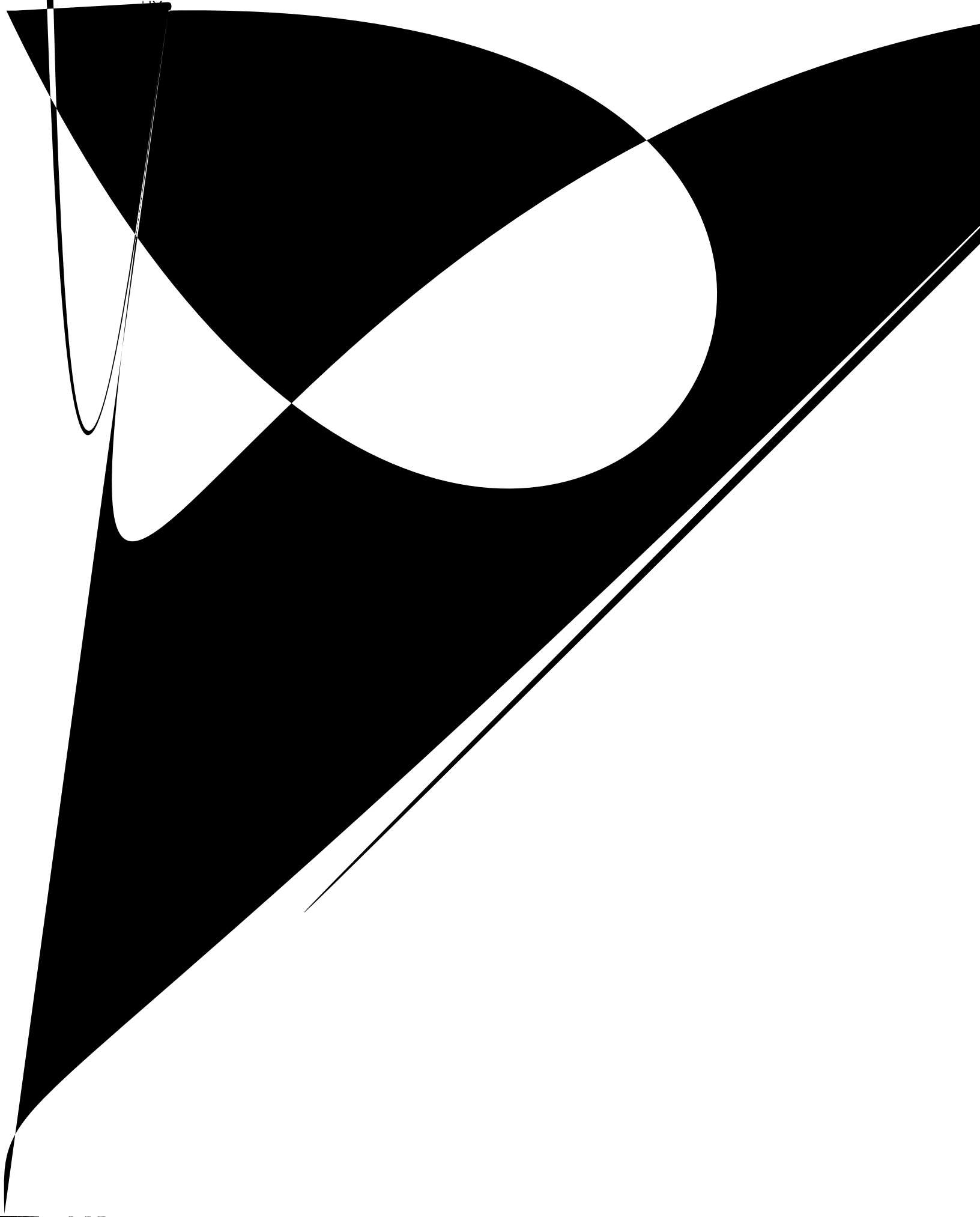

### 3.23 Model M-3547 Dyna-Jack<sup>®</sup>

#### Description

- Pump / Motor / Reservoir / Valve
- Check Valve
- 2 x 2-Way /2-Position and 2 x 3-Way/2-Position Solenoid Operated Cartridge Valves Located Externally and Manifolder Directly to Power Unit. Circuit Operates One Double Acting Cylinder With Both Ports Positively Checked
- Externally Adjustable Relief Valve
- #6 SAE Outlet
- Horizontal Mounting Standard

#### Popular Options

- Unit May be Wired to Independently Operate 2 x Single Acting Cylinders. Consult Factory For Proper Control Station
- Externally Adjustable Relief Valve May Be Installed In C1 or C2 Port
- 04286 Valve Spacer is Available to Provide Additional Clearance for Large Reservoirs when Required
- Vertical Mounting / Motor Up

#### Schematic

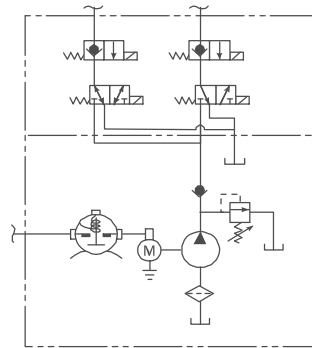

### 3.24 Model M-3551 Dyna-Jack®

#### Description

- Pump / Motor / Reservoir / Valve
- Check Valve
- Externally Adjustable Relief Valve
- 1 x 4-Way/2-Position and 1 x 2-Way/2-Position Normally Closed Solenoid Cartridge Valve Located in the Base
- Externally Adjustable Relief Valve in C2 Port
- #6 SAE Outlet
- Horizontal Mounting Standard

#### Popular Options

- Pressure Compensated (Cartridge Style) Flow Control Orifice In C1 Port
- Control Box and Cord
- Vertical Mounting / Motor Up

#### Schematic

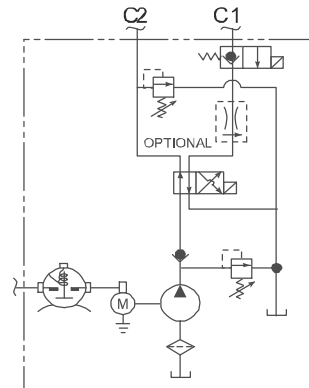

### 3.25 Model 3.25 HF Dyna-Jack® (High Flow)

#### Description

- Pump / Motor / Reservoir / Relief Valves
- Externally Adjustable Relief Valve
- Main Check Valve
- Total Pressure Drop Thru Base of Comp. Flow Control Installed <150 PSI (10.3 M (30 LPM) for Fast and Controlled Lowering
- 1 x 4-Way/2 Position and 1 x 2-Way/2 Position Closed High Flow Solenoid Cartridge at the Base (Maximum Lowering Speed Set by Pressure Compensated Orifice
- C1 Port Positively Checked
- Pressure Compensated (Cartridge Style) Orifice Port For Control of Maximum Lowering Speed
- Externally Adjustable Low Pressure Relief Valve in C2 Port For System Efficiency and Safety
- Horizontal Mounting Standard
- #8 (3/4-16) SAE Outlet

#### Popular Options

- Control Box and Cord
- Vertical Mounting / Motor Up

#### Schematic

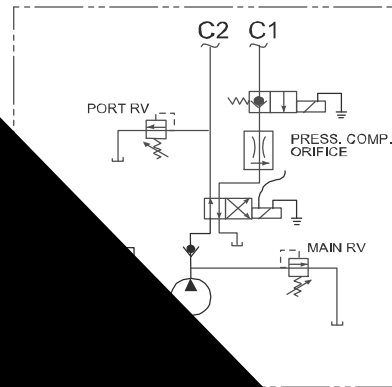

### 3.26 Model M-3554 Dyna-Jack<sup>®</sup>

#### Description

- Pump / Motor / Reservoir / Valve
- Check Valve
- Externally Adjustable Relief Valve
- 1, 4-Way/2-Position for Double-Acting Solenoid Cartridge Valve Located in the Base
- C1 Port Positively Checked
- Externally Adjustable Relief Valve in C2 Port
- Horizontal Mounting Standard
- #6 SAE Outlet

#### Popular Options

- Pressure Compensated (Cartridge Style) Flow Control Orifice In C1 Port
- Control Box and Cord
- Vertical Mounting / Motor Up

#### Schematic

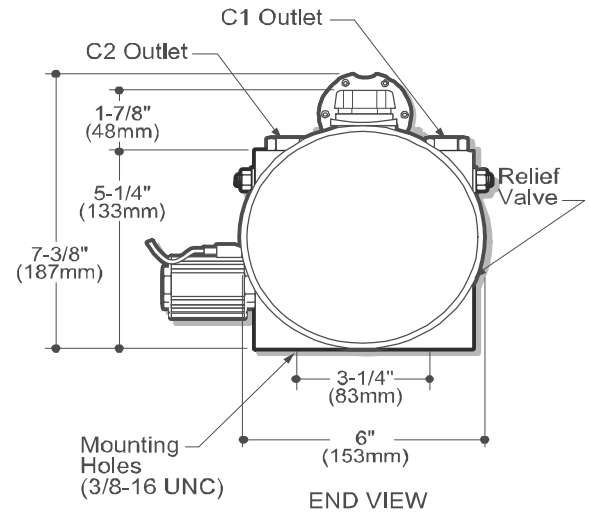
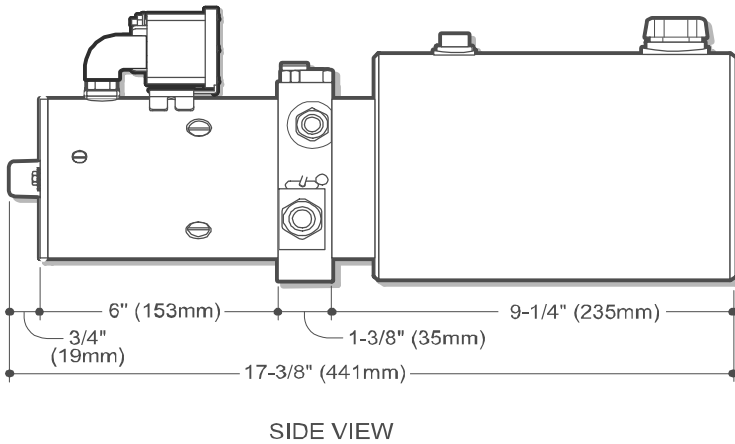
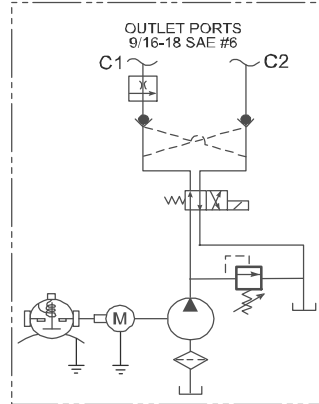

#### How to Order Your M-3354 Dyna-Jack<sup>®</sup>

Comprehensive information may be found on the page referenced below each selection category.

Shown as standard with:

Pump	Motor	Voltage	Reservoir (Length)	Motor Start Switch	Mounting Position	Accessories	Control Boxes
	08111	12	06042	17757	Horizontal		
Ref. Page 51	Ref. Page 62		Ref. Page 86-96	Ref. Page 99		Ref. Page 102	Ref. Page 100

### 3.27 Model M-3552 Dyna-Jack®

#### Description

- Pump / Motor / Reservoir / Valve
- Check Valve
- Externally Adjustable Relief Valve
- 1 x 4-Way/2-Position Solenoid Cartridge Valve and 1 x 2-Way/2-Position Solenoid Cartridge Valve Located Externally. Manifolded Directly To Unit
- C1 Port Positively Checked
- Externally Adjustable Relief Valve in C2 Port
- #6 SAE Outlet
- Horizontal Mounting Standard

#### Popular Options

- Pressure Compensated (Cartridge Style) Flow Control In C1 Port
- Control Box and Cord
- Vertical Mounting / Motor Up

#### Schematic

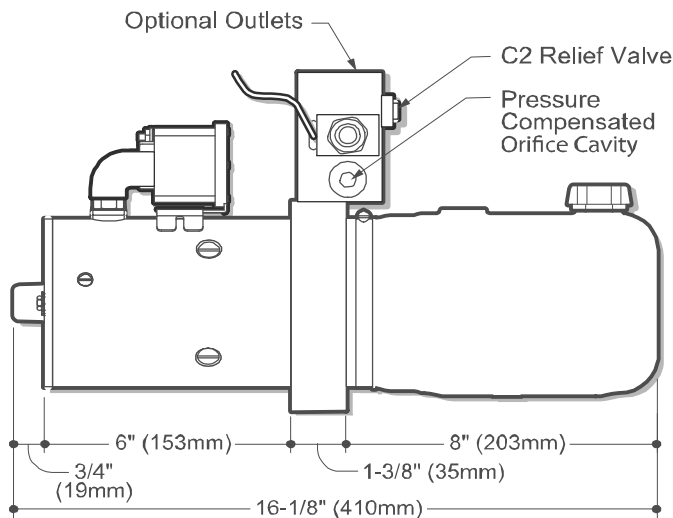
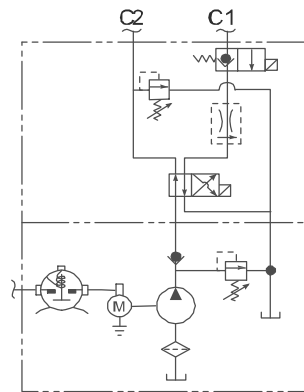

SIDE VIEW

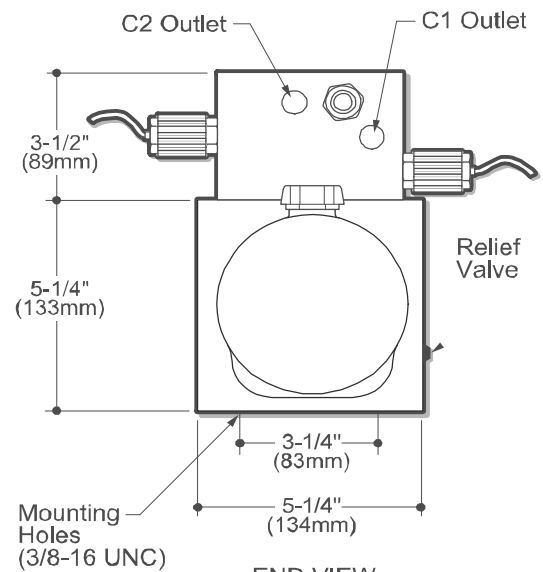

END VIEW

#### How to Order Your M-3552 Dyna-Jack®

Comprehensive information may be found on the page referenced below each selection category.

Shown as standard with:

Pump	Motor	Voltage	Reservoir (Length)	Motor Start Switch	Mounting Position	Accessories	Control Boxes
	08111	12	06102	17757	Horizontal		
Ref. Page 51	Ref. Page 62		Ref. Page 86-96	Ref. Page 99		Ref. Page 102	Ref. Page 100

### 3.28 Model M-642 Dyna Ramic®

#### Description

- Pump / Motor / Reservoir / Valve
- Check Valve
- 4-Way/2-Position and 2-Way/2-Position N.C. Solenoid Cartridge Valves Located Inside Reservoir
- C1 Port Positively Checked
- C1 and C2 Ports are Filtered
- Externally Adjustable Relief Valve
- .250 Inch NPT Outlets
- Horizontal Mounting Standard

#### Popular Options

- Horizontal Mounting Standard
- Control Box and Cord
- Vertical Mounting / Motor Up

#### Schematic

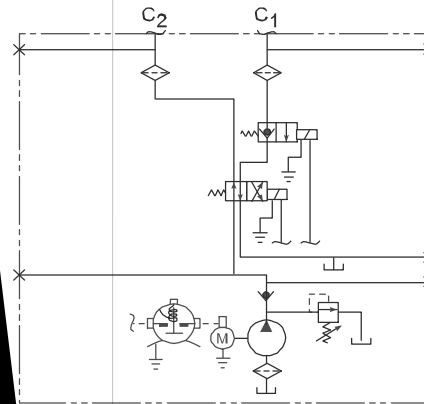

Optional Control

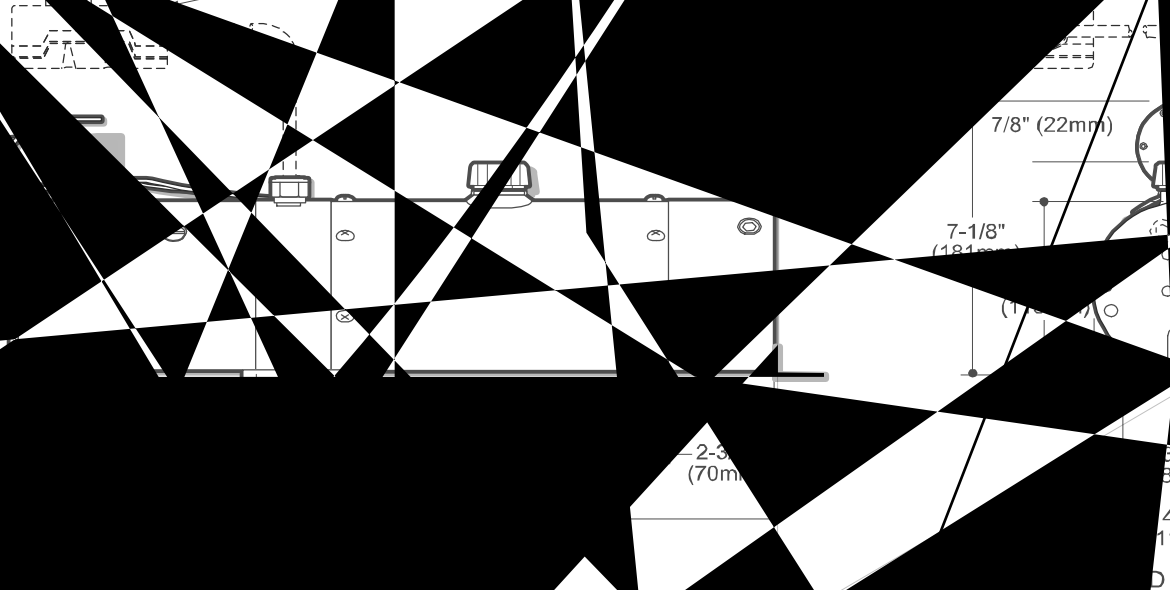

### 3.29 Model M-500-4W/3W Dyna-Jack®

#### Description

- Pump / Motor / Reservoir / Valve
- Check Valve
- Manually Operated 3-Way Valve (Outlet Port Checked) and 4-Way Valve. Electrical Contacts for Starting Motor When Valve Is Actuated
- Externally Adjustable Relief Valve
- .250 Inch NPT Outlets
- Horizontal Mounting Standard

#### Schematic

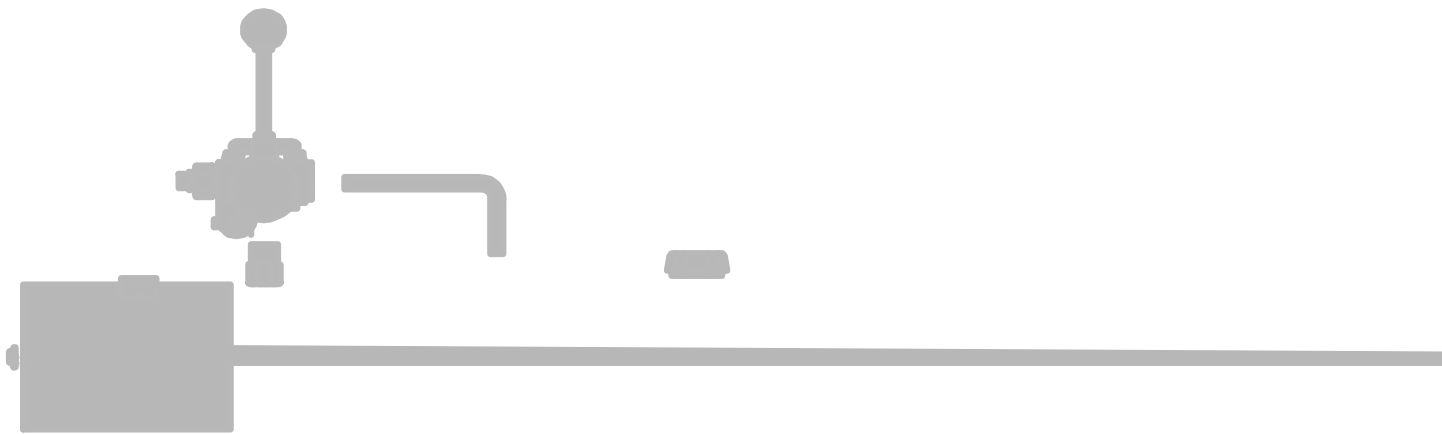
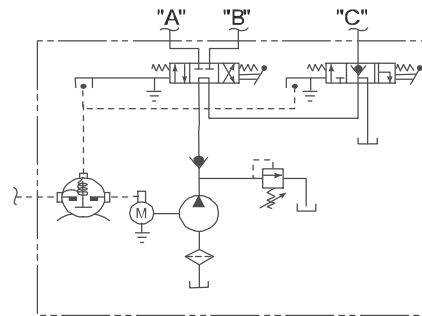

### 3.30 Model M-683 Dyna Ramic ®

#### Description

- Pump / Motor / Reservoir / Valve
- Check Valve
- 1 4-Way/2-Position and 3 x 2-Way/2-Position N.C. Solenoid Cartridge Valves Located Inside Reservoir provide 4W/3W Function
- All Ports Filtered
- By-Pass (Also Referred to as Cross-Over) Relief Valves Are Located Between C1 and C2 Ports
- Cord with Connector Plug
- Externally Adjustable Relief Valve
- .250 Inch NPT Outlets
- Horizontal Mounting Standard

#### Popular Options

- Control Box
- Vertical Mounting / Motor Up

#### Typical Application

- Snow Plow. Up. Down. Float; Left. Right

#### Schematic

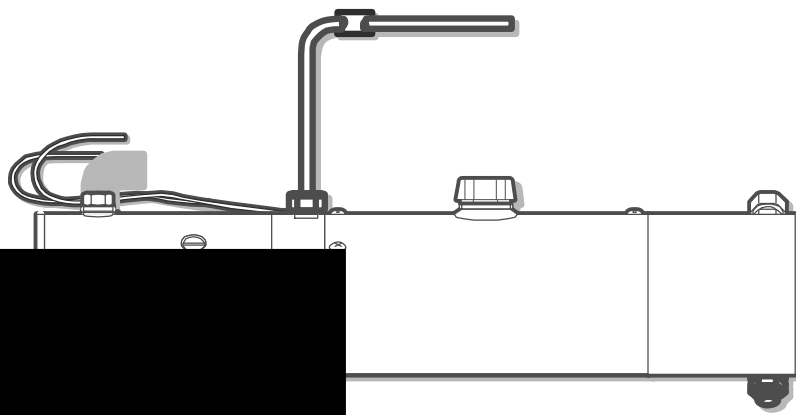
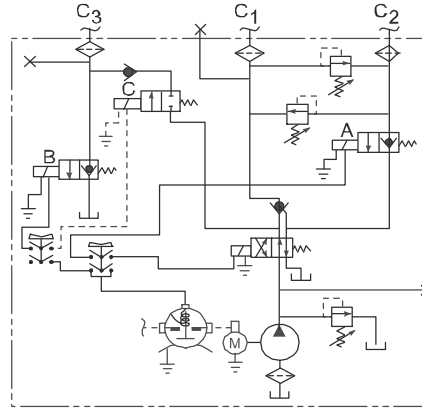

SIDE VIEW

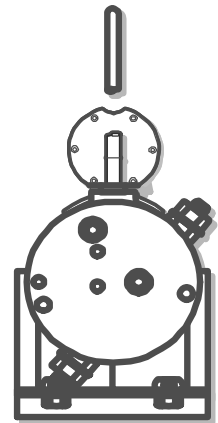

END VIEW

### 3.31 Model M-3528 Dyna-Jack<sup>®</sup>

#### Description

- Pump / Motor / Reservoir / Valve
- Check Valve in "P" Port
- Externally Adjustable Relief Valve
- 2 x D03 Solenoid Valve
- #6 SAE Outlet
- Horizontal Mounting Standard

#### Popular Options

- Control Box and Cord
- Vertical Mounting / Motor Up
- Large Selection of D03/CETOP Valves and Accessories

#### Schematic

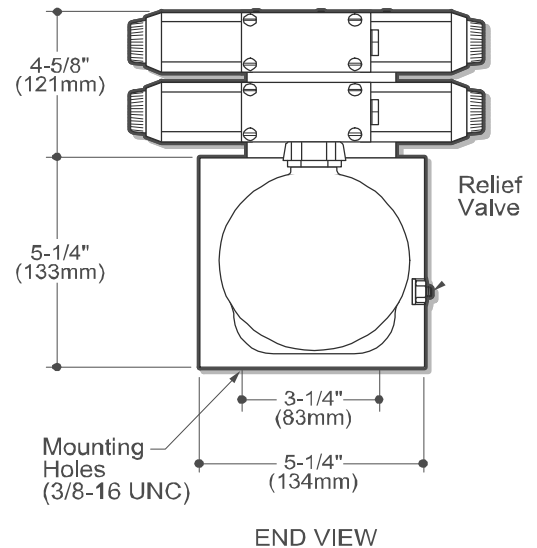
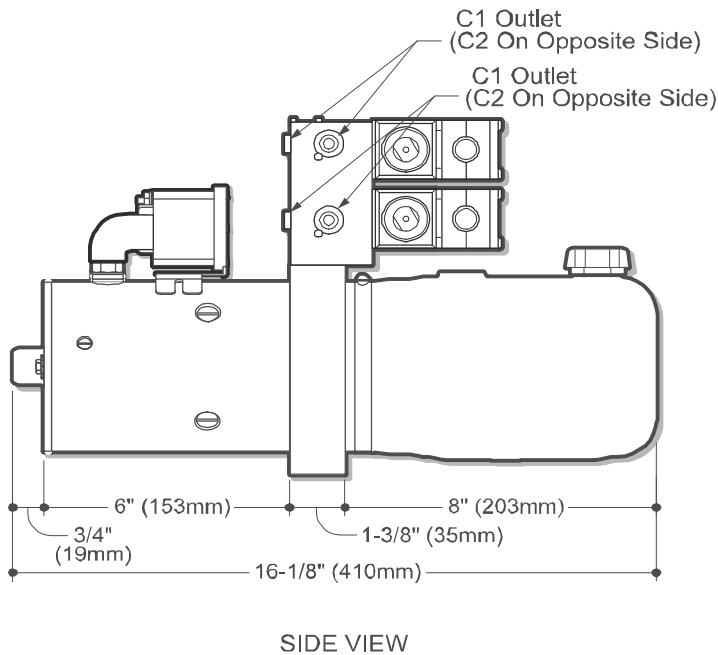
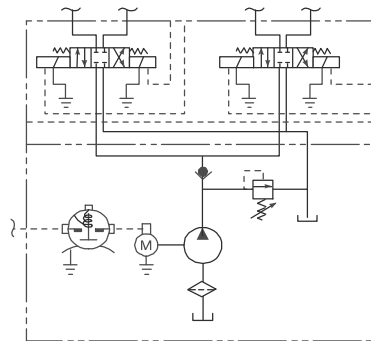

NOTE:  
An Adapter May Be Required With Certain Reservoirs - Consult Factory.

#### How to Order Your M-3528 Dyna-Jack<sup>®</sup>

Comprehensive information may be found on the page referenced below each selection category.

Shown as standard with:

Pump	Motor	Voltage	Reservoir (Length)	Motor Start Switch	Mounting Position	Accessories	Control Boxes
	08111	12	06102	17757	Horizontal		
Ref. Page 51	Ref. Page 62		Ref. Page 86-96	Ref. Page 99		Ref. Page 102	Ref. Page 100

### 3.32 Model M-3529 Dyna-Jack®

#### Description

- Pump / Motor / Reservoir / Manifold
- Check Valve in "P" Port
- Externally Adjustable Relief Valve
- #6 SAE Outlet
- Horizontal Mounting Standard

#### Popular Options

- Control Box and Cord
- Vertical Mounting / Motor Up
- Large Selection of D03/CETOP Valves and Accessories

#### Schematic

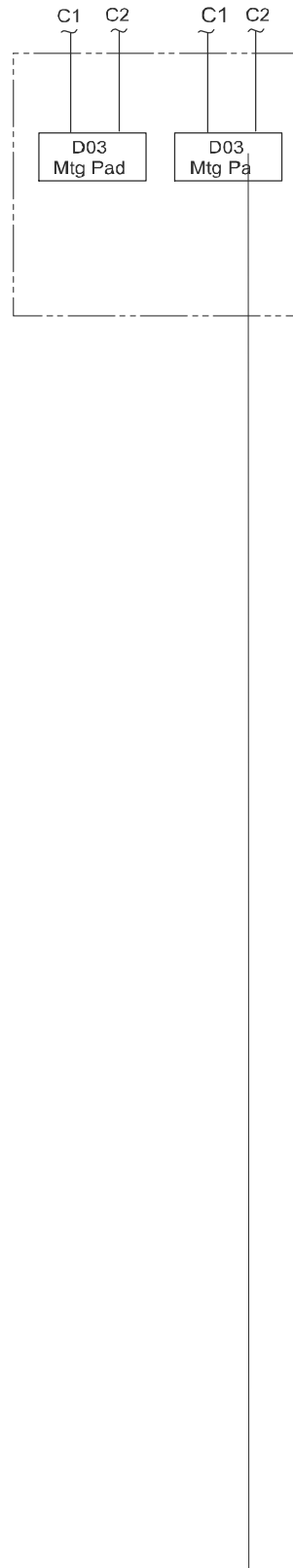

### 3.33 Model M-3593 Dyna-Jack

#### Description

- Pump / Motor / Reservoir / Valve
- Externally Adjustable Relief Valve
- Solenoid Cartridge Valves, Pilot Operate and Adjustable Cross-Over Relief System Compact Manifold
- Ideal System For Operating a Snow P  
Hold, Gravity Down, Left, Right
- Horizontal Mounting Standard

#### Popular Options

- Control Box and Cord
- Vertical Mounting / Motor Up

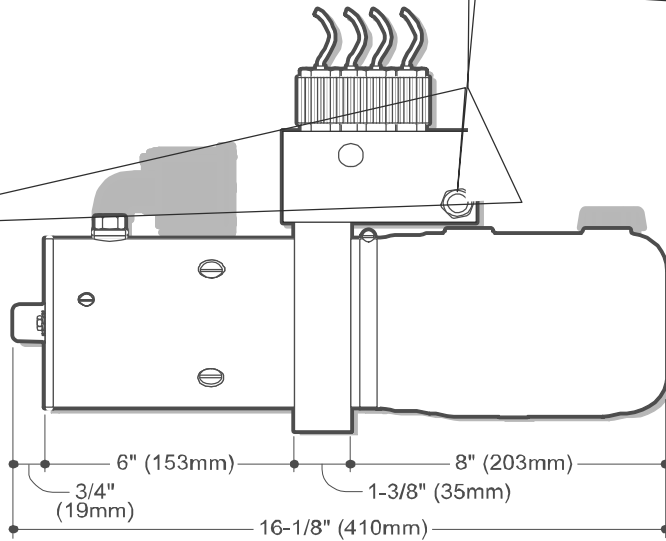
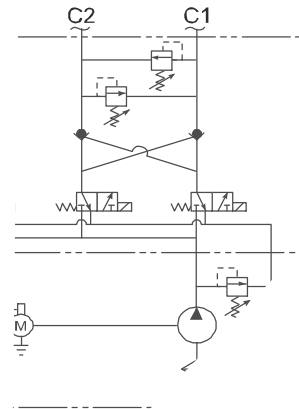

SIDE VIEW

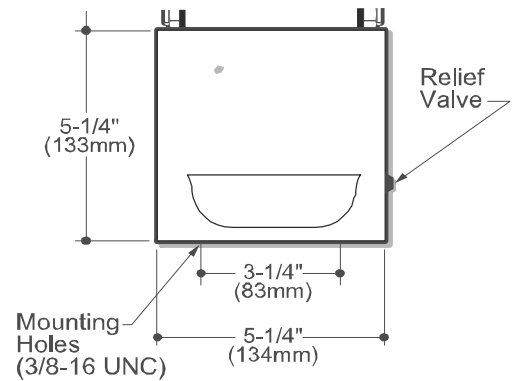

END VIEW

### 3.34 Modular Power Units

#### Description

- Add Standard or Custom Manifolds to a Basic M-3598 Power Unit with "P" and "T" Ports.
- Modular Manifolds Mount to Standard Pad. Allow for a Building Block Approach to Power Unit Flexibility and Circuit Design.
- For Use With All Monarch Pumps, Motors, and Reservoirs. Note - A spacer may be required with certain reservoirs, on others the valve package may cover reservoir fill and return ports - consult factory.

#### Schematic

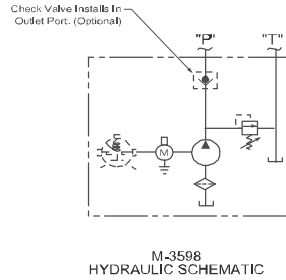

#### Model M-3598

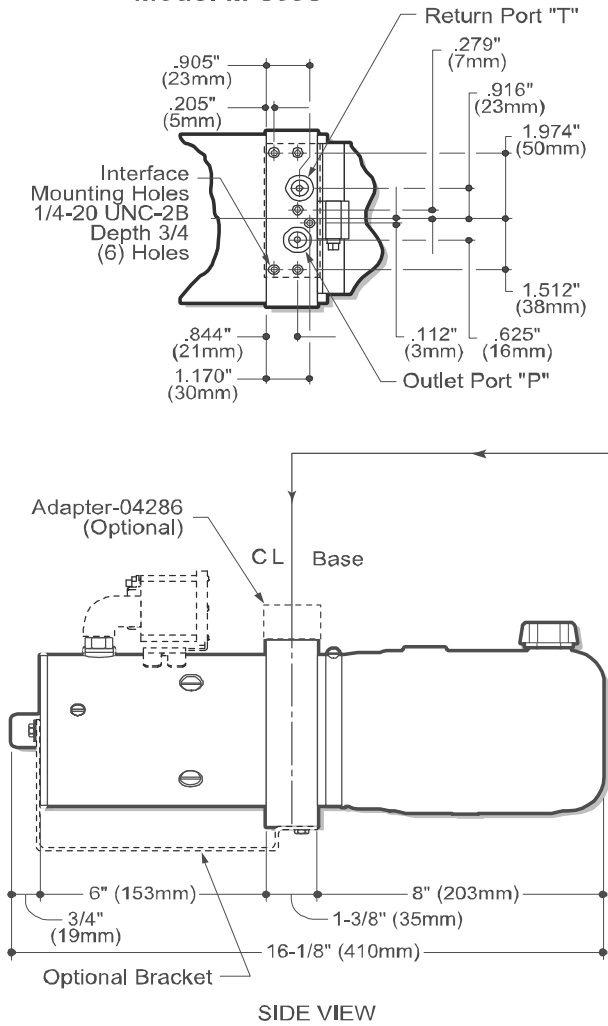

Monarch Modular Systems Flexible Solutuions As You Need Them

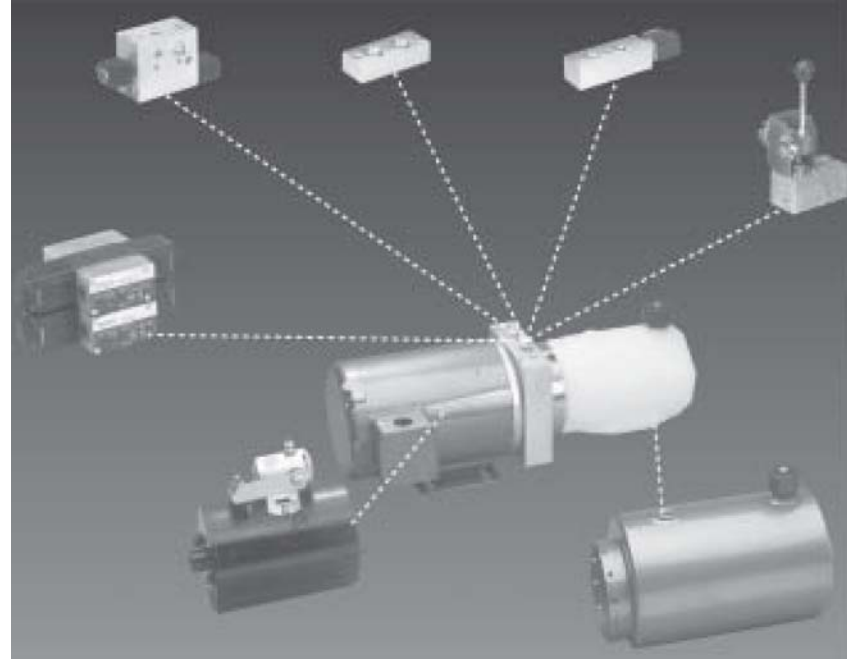

Add Any Of The Following Circuits To The M-3598 Power unit

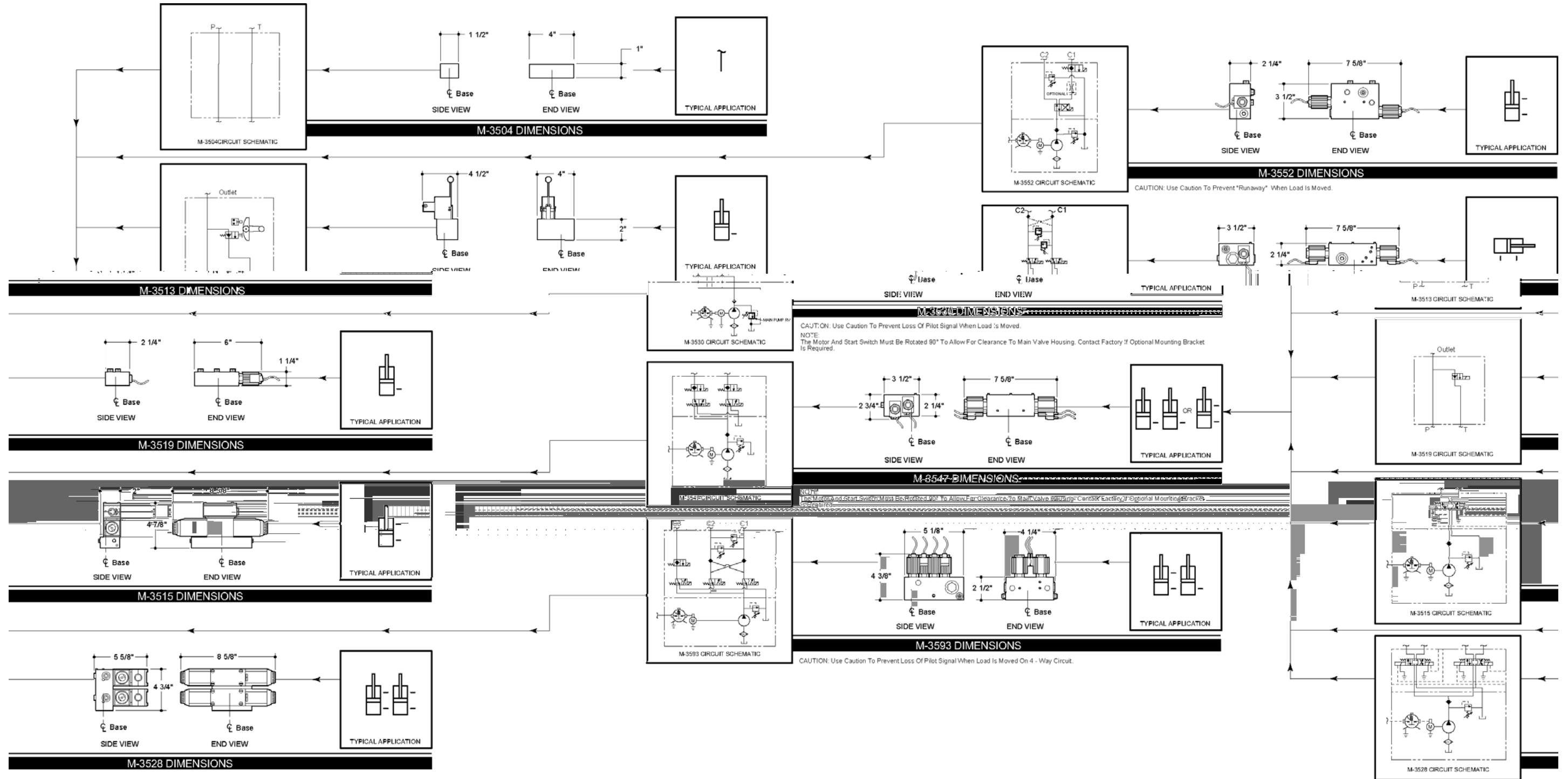

### 3.35 How to Order Your Modular Power Unit

Select from the following options. Comprehensive information may be found on the page referenced below each selection category.

Model M-

Select Model	Pump	Motor	Voltage	Reservoir (Length)	Control Boxes	Motor Start Switch	Mounting Bracket	Mounting Position
Ref. Page	Ref. Page 51	Ref. Page 62		Ref. Page 86-96	Ref. Page 100	Ref. Page 99	Ref. Page 101	
M-3598	17-150	08053	12	4.5x8	07793	17757	Optional	Horizontal
M-3504	17-190	08111	12	4.5x10	07795	17744	02238	
M-3513	17-270	08058	12	4.5x12	Specify Cord Length Inches	17744	01289	Vertical
M-3519	13-150	08058	12	4.5x13		Start Switch to Motor Cable		
M-3515	13-200					Bus Bar		
M-3528	13-250			6x9				
M-3542	13-200			6x10				
M-3552	13-380			6x13.5				
M-3530		08196	12	6x8				
M-3547		08050	12					
M-3593		08163	12	5.5x6.5x10				
		08051	24	5.5x6.5x13.5				
		08120	24	5.5x6.5x19				
		08035	24	6.25x7x7				
		08055	36	6.25x7x7				
		08168	36	6.25x7x12				
		08055	48	6.25x7x15				
		08174	72	6.25x7x15				
				6.25x7x21				

\*Max Flow  
= 2.75 GPM

### 3.36 S-326 Pump/Motor Units

S-326 Units Feature SAE AA and SAE A Pumps and Permanent Magnet Motors.

Permanent magnet motors are typically used to operate hydraulic equipment for material handling devices, aerial platforms, and emergency back-up systems because they provide extended run times and linear pump outputs at various pressures for smooth operation. Pressure loaded pumps deliver high volumetric efficiency and are fitted with spline shafts for optimum engagement with the motor drive shaft.

Please select a motor and pump combination from the following chart and performance curves. Motor thermal data (run time) may be found on page 86.

Part Number	Voltage	Pump Interface	Insulation Class	Dimension Page	Performance Curve	Number of Terminals	Frame	UL Listed	Description *See Key
08164	12	SAE AA 1/2" Spline	F	45.0	AA	2	48 (5.6" ø)	No	OFC
08166	24	SAE AA 1/2" Spline	F	45.0	AB	2	48 (5.6" ø)	No	OFC
08167	24	SAE A 5/8" Spline	F	45.0	AD	2	48 (5.6" ø)	No	OFC
08169	36	SAE AA 1/2" Spline	F	45.0	AF	2	48 (5.6" ø)	No	OFC
08170	36	SAE A 5/8" Spline	F	45.0	AG	2	48 (5.6" ø)	No	OFC
08171	48	SAE AA 1/2" Spline	F	45.0	AH	2	48 (5.6" ø)	No	OFC
08172	48	SAE AA 5/8" Spline	F	45.0	AI	2	48 (5.6" ø)	No	OFC
08175	72	SAE AA 1/2" Spline	F	45.0	AJ	2	48 (5.6" ø)	No	OFC
08176	72	SAE A 5/8" Spline	F	45.0	AK	2	48 (5.6" ø)	No	OFC
08734		BAND KIT		45.0					

\*Abbreviation Key:  
OFC = Open Fan Cooled

A band kit is available that will convert the motor from OFC to EFC (Enclosed Fan Cooled). Use of the band reduces thermal performance. Please contact the factory for more information.

Specifications, descriptions, and illustrative material contained herein were as accurate as known at the time this publication was approved for printing. Bucher Hydraulics, Inc. reserves the right to discontinue models at any time or change specifications without notice or incurring obligation.

### 3.37 Dimensional Information for S-326 Pump/Motor Units

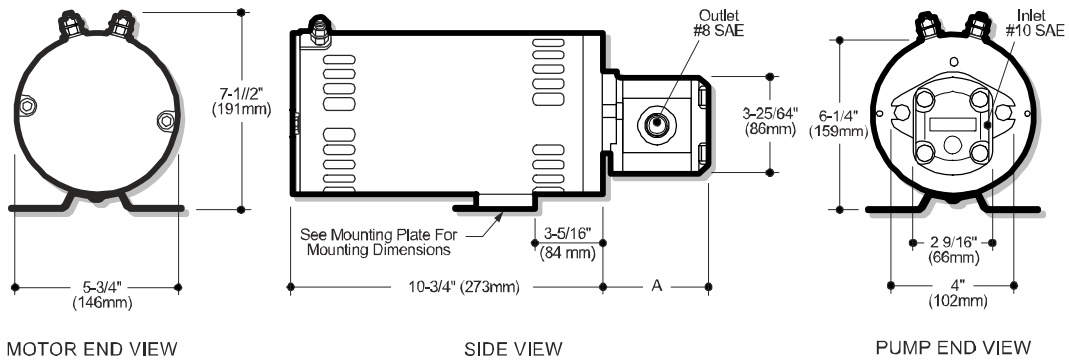

#### End View and Side View of Motor with SAE AA Pump

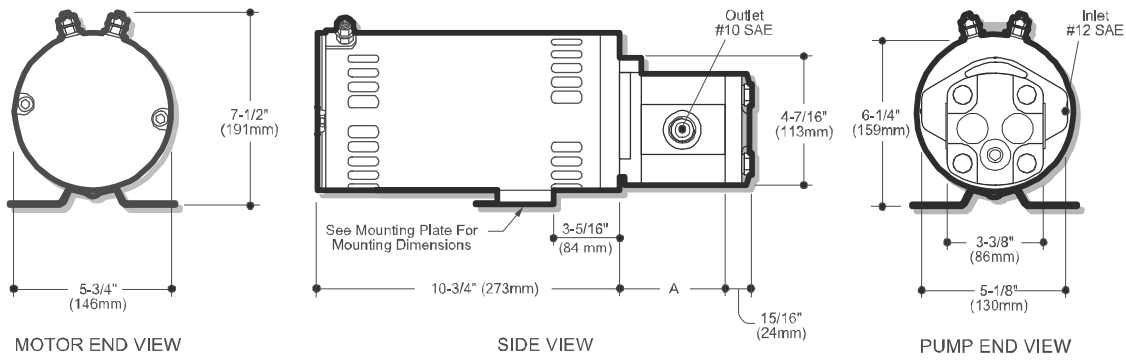

#### End View and Side View of Motor with SAE A Pump

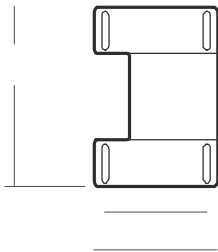

### 3.38 SAE AA Pump Data

Pump Code	DISPLACEMENT In <sup>3</sup> /Rev	"A" DIMENSION (Inches)
1.4	0.081	3.23
2.1	0.126	3.23
2.8	0.166	3.23
3.5	0.200	3.46
4.1	0.248	3.46
5.2	0.317	3.70
6.1	0.369	3.70

### 3.39 SAE A Pump Data

Pump Code	DISPLACEMENT In <sup>3</sup> /Rev	"A" DIMENSION (Inches)
4.5	0.27	1.83
6.2	0.37	1.83
8.3	0.50	2.05

### 3.40 How to Order S-326 Pump/Motor Units

Please select from the following options:

MODEL S-326-

SAE PUMP SIZE	PUMP CODE	MOTOR	VOLTAGE
AA	1.4	08164	12
	2.1	08166	24
	2.8	08169	36
	3.5	08171	48
	4.1	08175	72
	5.2		
	6.1		
A	4.5	08167	24
	6.2	08170	36
	8.3	08172	48
		08176	72

Example: S-326-AA-2.8-08166-24 is an SAE AA 2.8 Pump (0.166 in<sup>3</sup>/rev) attached to a 24V D. C. Permanent Magnet Motor.

### 3.41 M Series D.C. Pump Data

PUMP CODE	On Performance Curves	DISPLACEMENT In <sup>3</sup> /Rev (Cm <sup>3</sup> /Rev)
12637 - 100 (New)	17-100	0.022 (0.361)
12637 - 120 (71)	17-120	0.027 (0.443)
12637 - 150 (72)*	17-150	0.032 (0.524)
12637 - 190 (73)*	17-190	0.042 (0.690)
12637 - 270 (62)*	17-270	0.057 (0.934)
12171 - 150 (42)	17-150	0.077 (1.26)
12171 - 200 (43)	17-200	0.099 (1.66)
12171 - 250 (03)	17-250	0.125 (2.13)
12171 - 270 (51)	17-270	0.137 (2.31)
12171 - 330 (New)	17-330	0.168 (2.76)
12171 - 380 (05)	17-380	0.193 (3.23)

\* denotes i - Pump

#### Recommended Operating Conditions for M Series Pumps:

Operating Temperature: -20°F to 130°F (-29°C to 54°C)

#### Oil Viscosity:

- Optimum 100 to 350 SUS (Cst = .22 x SUS - 135/SUS)
- Minimum 100 SUS at Operating
- Maximum Start Up 4000 SUS

#### Recommended Fluid for indoor use:

- Mobil DTE 24 or equal

#### Recommended Fluid for outdoor use:

- ATF Dexron II or equal

#### STANDARD PUMP FEATURES:

- Fixed Displacement, External Tooth Gears
- Hardcoat Processed Internal Pump Surfaces  
Extend Service Life
- Extremely Tolerant of Fluid Contaminants and Resistant to Galling Caused by Low Temperature Start-up
- Wide Temperature and Viscosity Operation
- Cost Effective



24 Volt D.C. Performance Curves

Voltage =  $25.2 - \sqrt{\frac{AMP - 40}{10}}$  Test Fluid = Mobil D.T.E. 24  
@ 100°F (SUS 160)  
34°C (CST 34)

3.44 Performance Curve AC

M Series Pumps

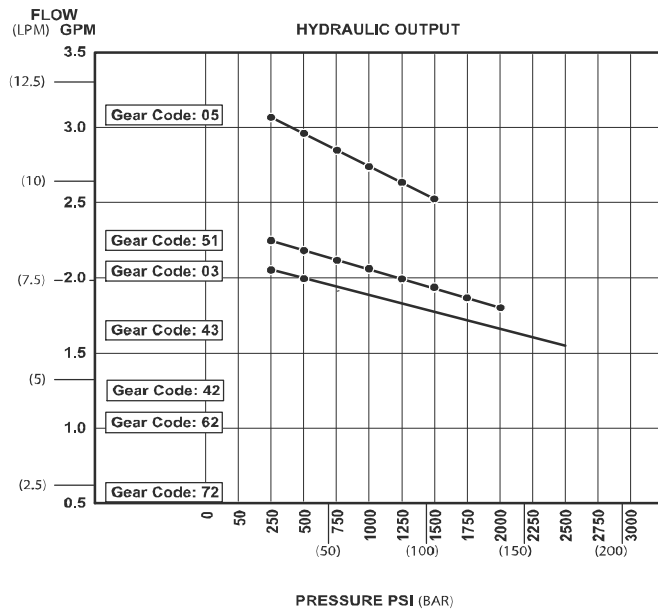

3.46 Performance Curve AE

M Series Pumps

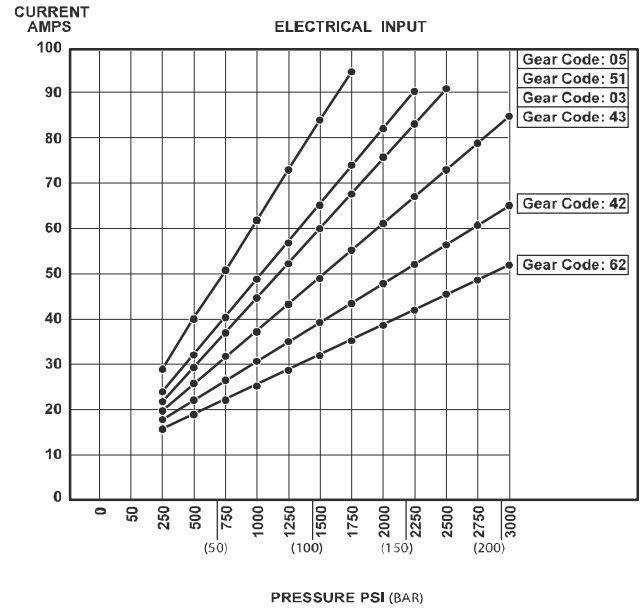
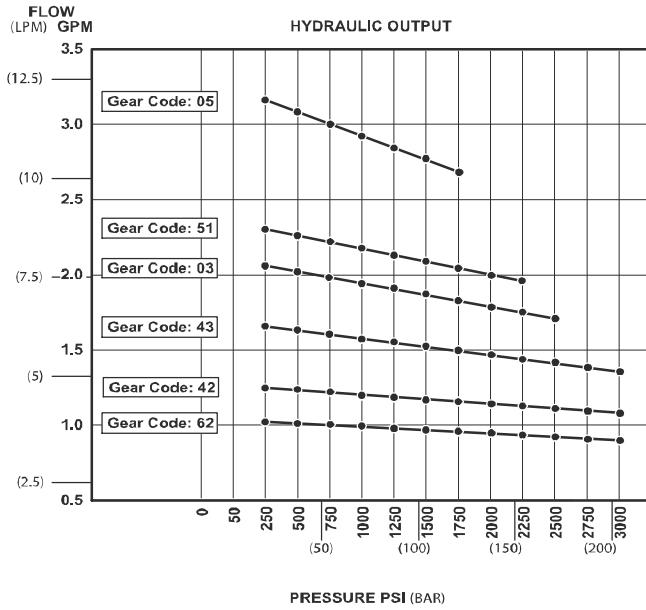

3.47 Performance Curve AF

SAE A Pumps

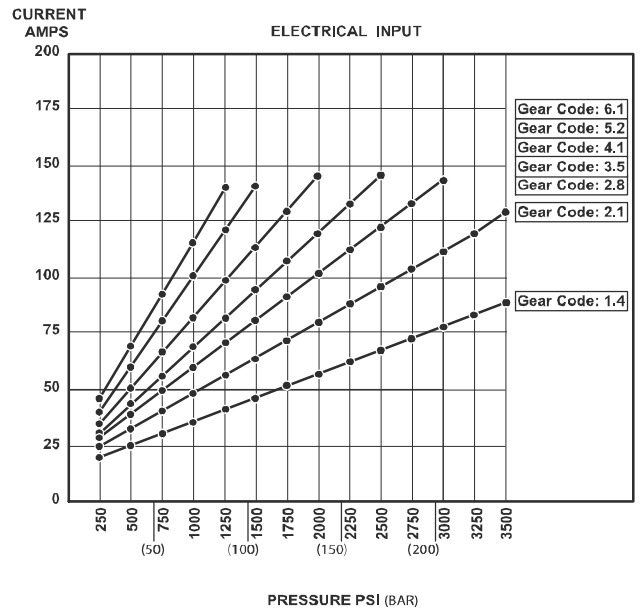
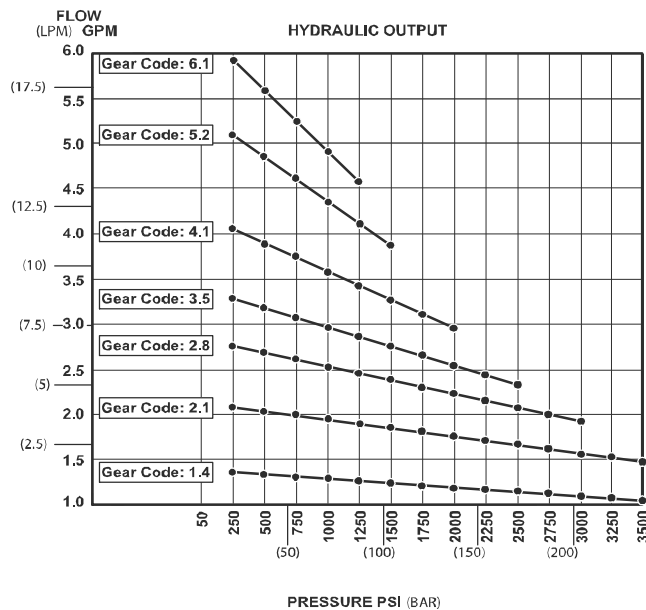

### 36 Volt D.C. Performance Curves

Voltage = 36.5 - .03 x AMPS

Test Fluid = Mobil D.T.E. 24  
@ 100°F (SUS 160)  
34°C (CST 34)

#### 3.48 Performance Curve AG

SAE A Pumps

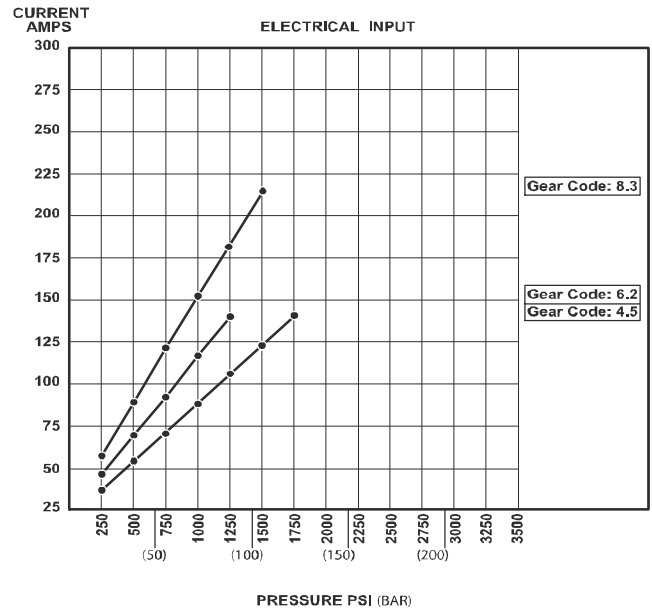
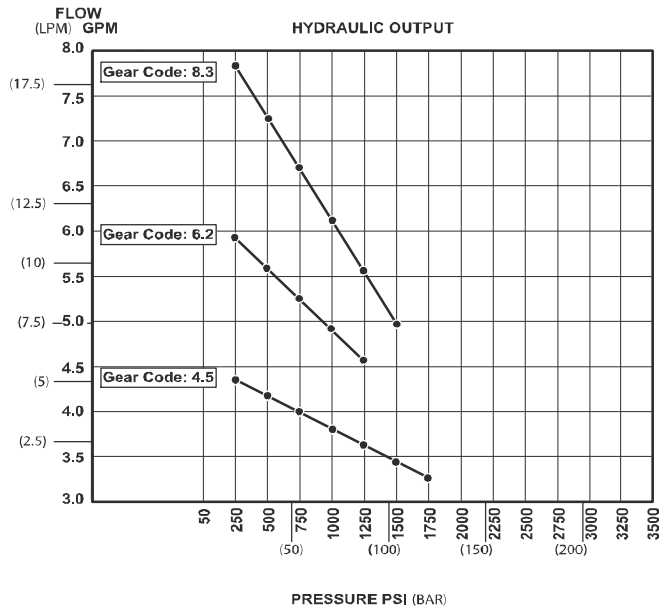

### 48 Volt D.C. Performance Curves

Voltage = 48.5 - .03 x AMPS

Test Fluid = Mobil D.T.E. 24  
@ 100°F (SUS 160)  
34°C (CST 34)

#### 3.49 Performance Curve AH

SAE AA Pumps

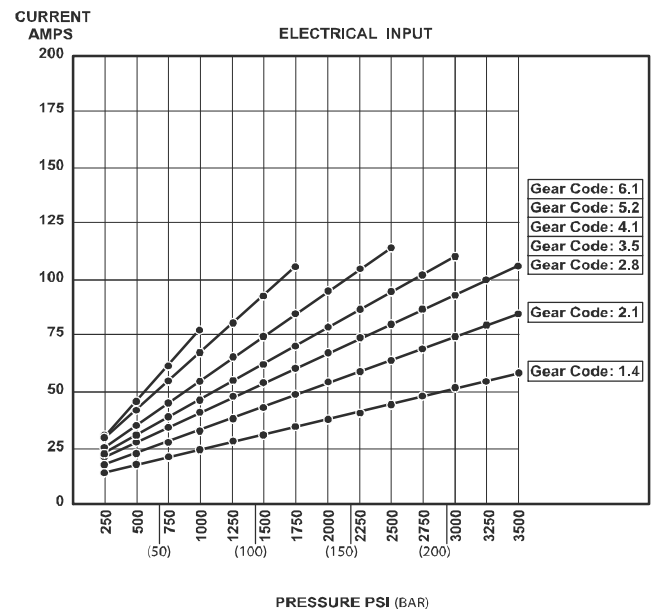
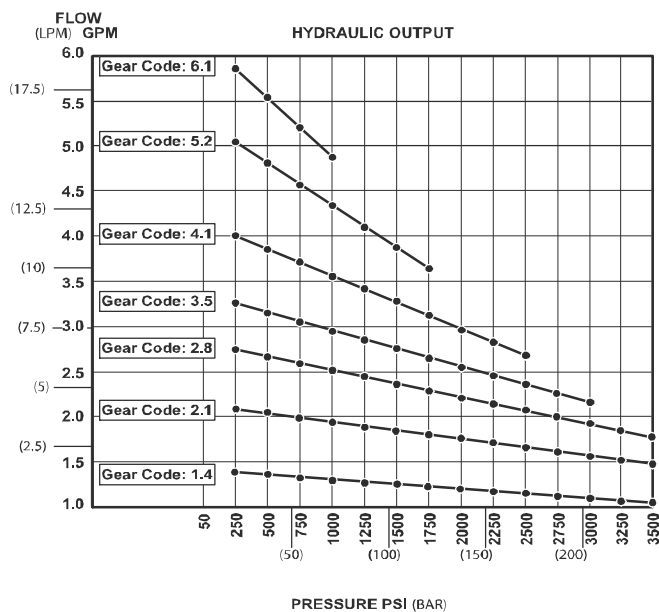

Voltage = 48.5 - .03 x AMPS

Test Fluid = Mobil D.T.E. 24  
@ 100°F (SUS 160)  
34°C (CST 34)

---

SAE A Pumps

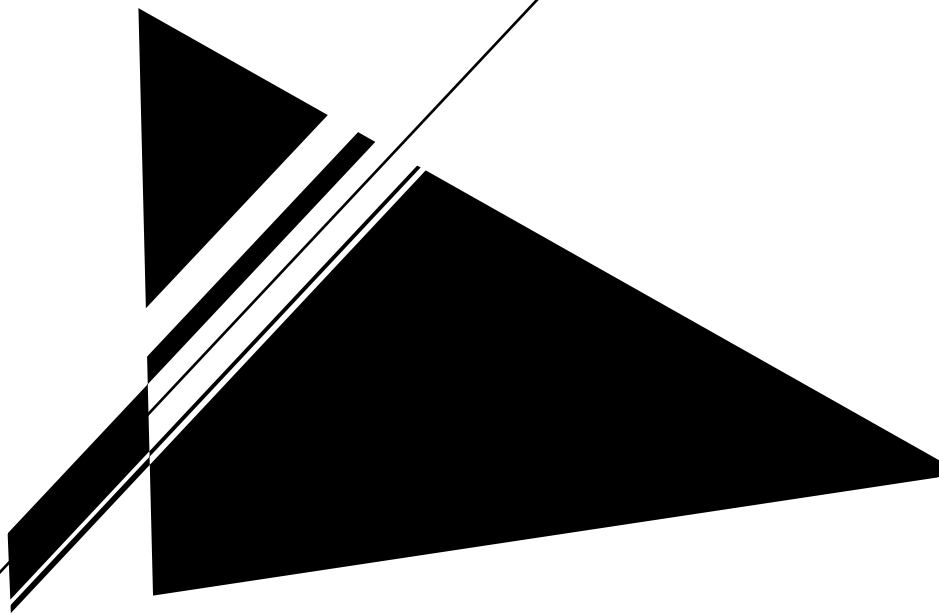

3.52 Performance Curve AK

SAE A Pumps

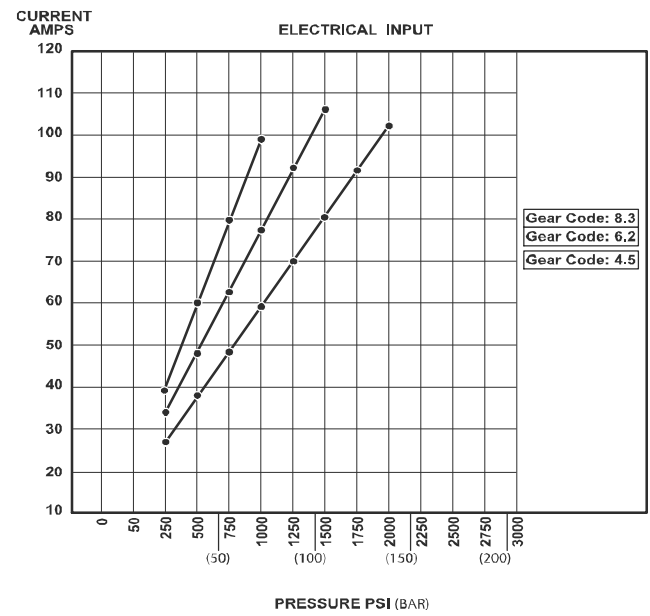
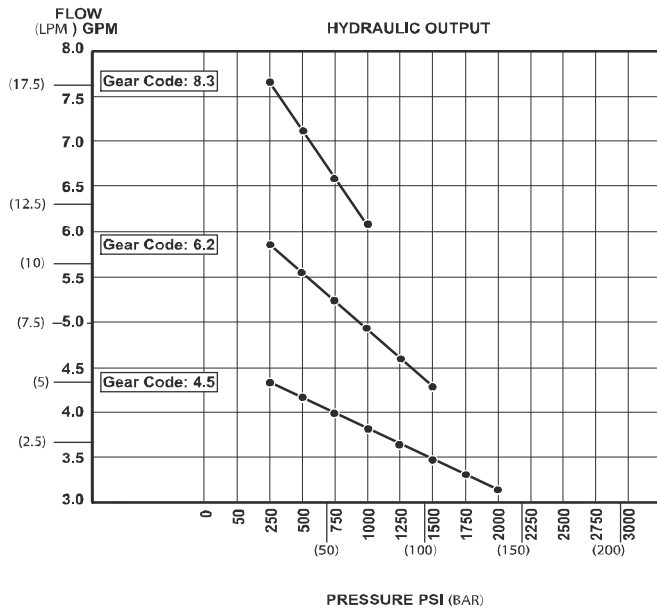

## 4 Birotational Hydraulic Power Systems

### 4.1 Birotational i - Pump

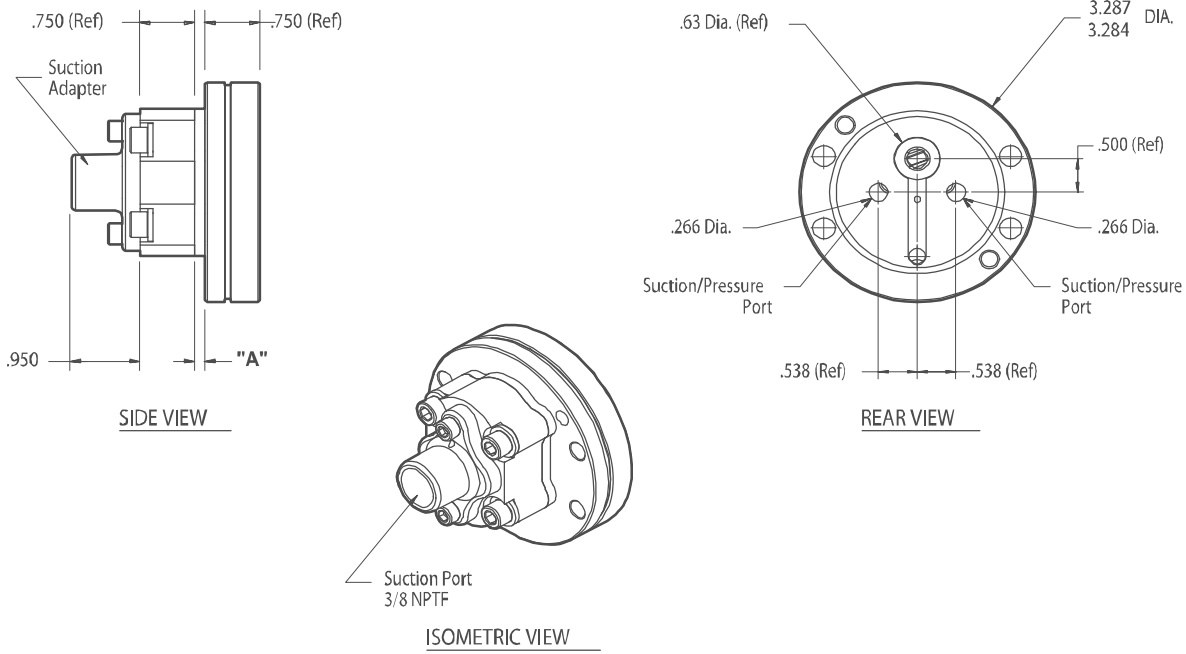

#### Bi-Rotational i - Pump Data

Pump Number	A"	Displacement (in <sup>3</sup> /R ev)	Displacement (cc/Rev)	Flow @ 1800 rpm (GPM)
12818-100	.100	0.022	0.36	0.17
12818-120	.120	0.027	0.44	0.21
12818-120	.150	0.032	0.52	0.25

## 4.2 Model M-3504

### Description

- Birotational Pump and Motor
- Check Valve
- Externally Adjustable
- #6 SAE Outlet
- Horizontal Mounting

### Popular Options

- Check Valve in C<sup>+</sup>
- Vertical Mounting

### Schematic

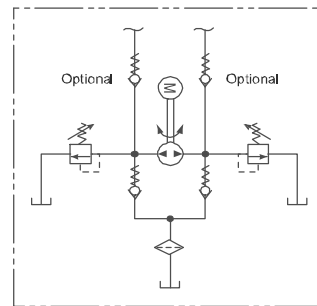

Options for Optional Manifold

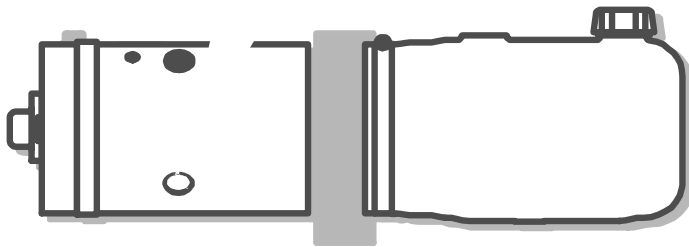

### 4.3 Model M-3530

#### Description

- Birotational Pump and Motor / Reservoir
- Check Valve
- Pilot-Operated Check Valves
- Externally Adjustable Relief Valve
- #6 SAE Outlet
- Horizontal Mounting

#### Popular Options

- Pressure Compensated Flow Controls
- Vertical Mounting

#### Schematic

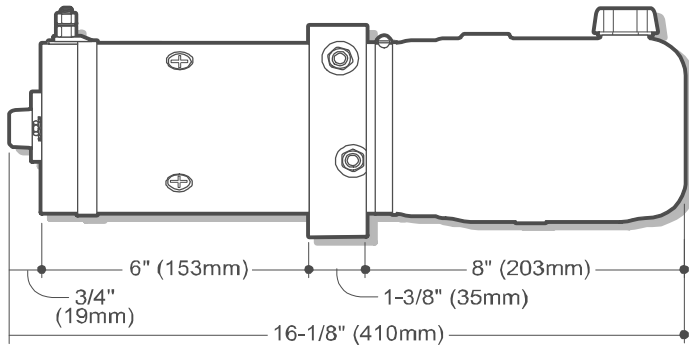
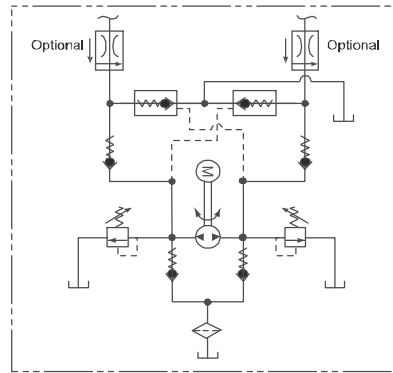

SIDE VIEW

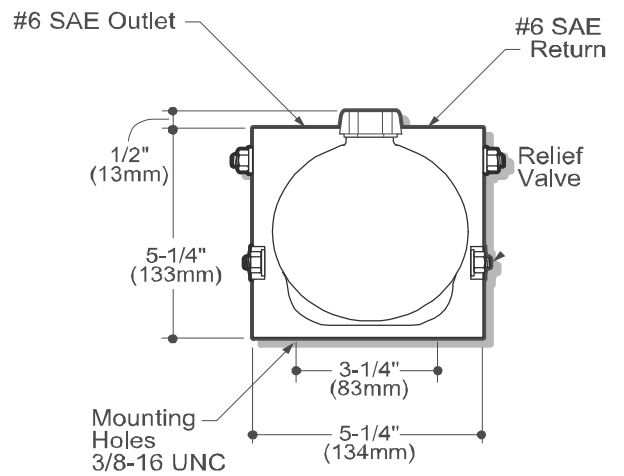

END VIEW

Consult factory for additional options and specifications.

## 4.4 Model M-3547

### Description

- Birotational Pump and Motor / Reservoir
- 2 x 2-Way/2 Position Solenoid Controlled Cartridge Valves Located Externally and Manifolded Directly to Unit.
- Check Valve
- Externally Adjustable Relief Valve
- #6 SAE Outlet
- Horizontal Mounting

### Popular Options

- Pressure Compensated Flow Controls
- Vertical Mounting

### Schematic

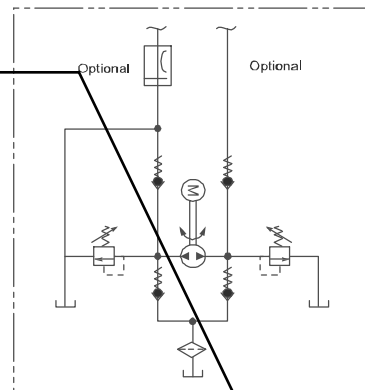

## 5 Dim. Information for Standard D.C. Motors with Performance Curves

### 5.1 M Series D.C. Motor Information

Part Number	Voltage	Insulation Class	Dimensions Page	Number of Terminals	Housing Diameter Inch (mm)	UL Listed	Description *See Key
08053	12	A	63	1	3" (77mm)	NO	PM/ID
08111	12	B	64	1	4.5" (115mm)	NO	SM/ID
08058	12	B	65	1	4.5" (115mm)	NO	SW/ID Ball Bearing Commutator End
18442	12	B	66	2	4.5" (115mm)	NO	SW/ID
08196	12	B	67	1	4.5" (115mm)	NO	SW/ID
08050	12	H	68	2	5.5" (140mm)	NO	SW/ID
08163	12	H	69	2	4.6" (117mm)	YES	PM/ID
08164	12	H	70	2	5.75" (146mm)	YES	PM/ID
08045	12	B	71	1	4.5" (115mm)	NO	SM/ID
08003	12	B		1	4.5" (115mm)	NO	SW/HD
08030	24	B	72	2	4.5" (115mm)	NO	SW/ID
08004	12	F	73	1	3.25" (83mm)	NO	PM/ID
08189	12	F	74	1	3.7" (??mm)	NO	SW/ID
08051	24	A	76	2	3" (77mm)	YES	PM/ID
08120	24	B	77	2	4.5" (115mm)	YES	SW/ID
08035	24	H	78	2	5.4" (??mm)	YES	PM/ID
08066	12	H	75	2	5.5" (140mm)	NO	SW/ID
08195	24	F	79	1	3.25" (83mm)	NO	PM/ID
08168	36	H	80	2	5" (117mm)	YES	PM/ID
08055	36/48	B	81	2	4.5" (115mm)	NO	SW/ID
08040	48	H	82	2	5" (117mm)	YES	PM/ID
08055	48/36	B	81	2	4.5" (115mm)	NO	SW/ID
08174	72/80	H	84	2	5" (117mm)	YES	PM/ID

\* Key to Abbreviations:

PM = Permanent Magnet  
ID = Intermittent Duty

SW = Series Wound  
CW = Compound Wound

ED = Extended Duty

HD = Heavy Duty

A Thermal Protection Switch is available as an option on most motors and must be used with solenoid motor start switch. For motor thermal performance data, refer to the thermal chart on page ??

## 5.2 08053 D.C. Motor Information

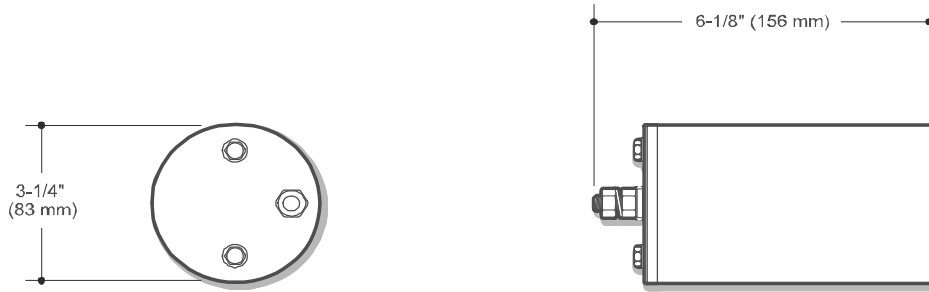

12 Volt D.C. Performance graphs

$$\text{Voltage} = 12.3 - \sqrt{\frac{\text{AMP} - 70}{43}}$$

Test Fluid = Mobil D.T.E. 24 @ 100°F (SUS 160) 34°C (CST 34)

Performance graphs for 08053 Motor

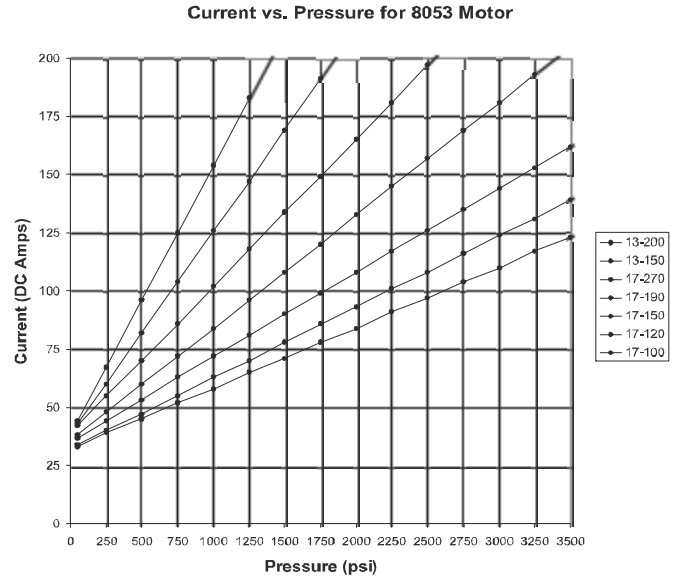
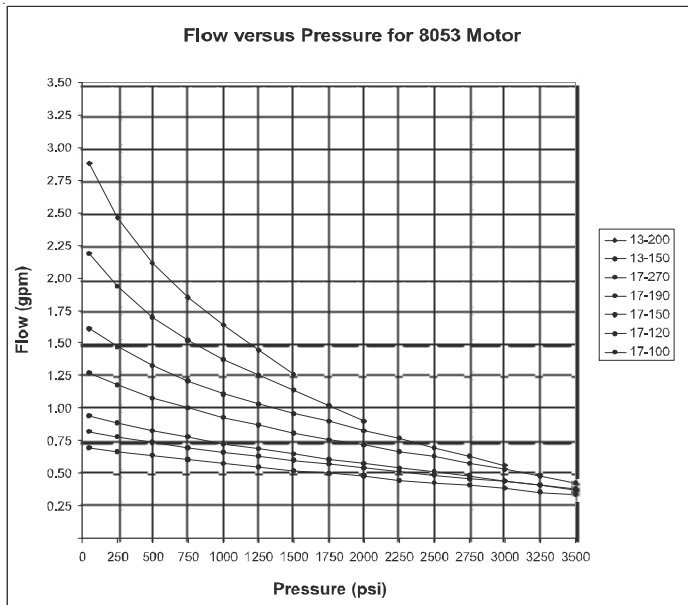

Part Number	Voltage	Insulation Class	Number of Terminal	UL Listed	Description * see Key
08053	12	A	2	NO	PM/ID

\* Key to Abbreviations:

PM = Permanent Magnet

SW = Series Wound

ED = Extended Duty

HD = Heavy Duty

ID = Intermittent Duty

CW = Compound Wound

A Thermal Protection Switch is available as an option on most motors and must be used with solenoid motor start switch. For motor thermal performance data, refer to the thermal chart on page 62



## 5.4 08058 D.C. Motor Information

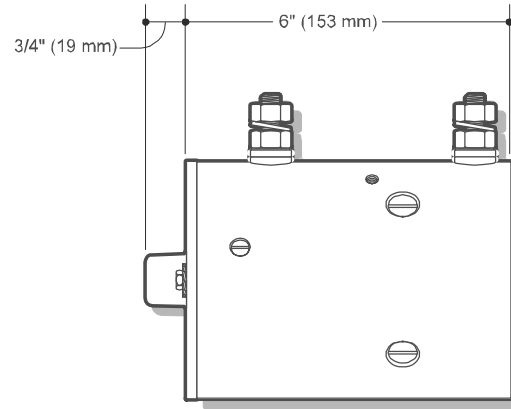
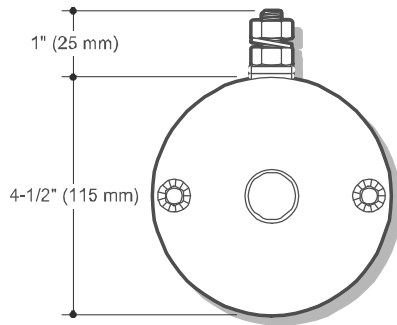

### 12 Volt D.C. Performance graphs

$$\text{Voltage} = 12.3 - \sqrt{\frac{\text{AMP} - 70}{43}}$$

Test Fluid = Mobil D.T.E. 24  
@ 100°F (SUS 160)  
34°C (CST 34)

### Performance graphs for 08058 Motor

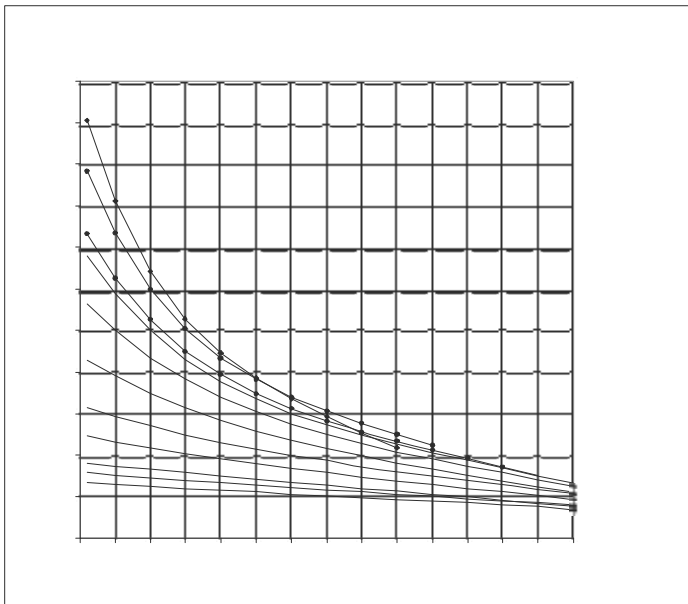

5.5 18442 D.C. Motor Information

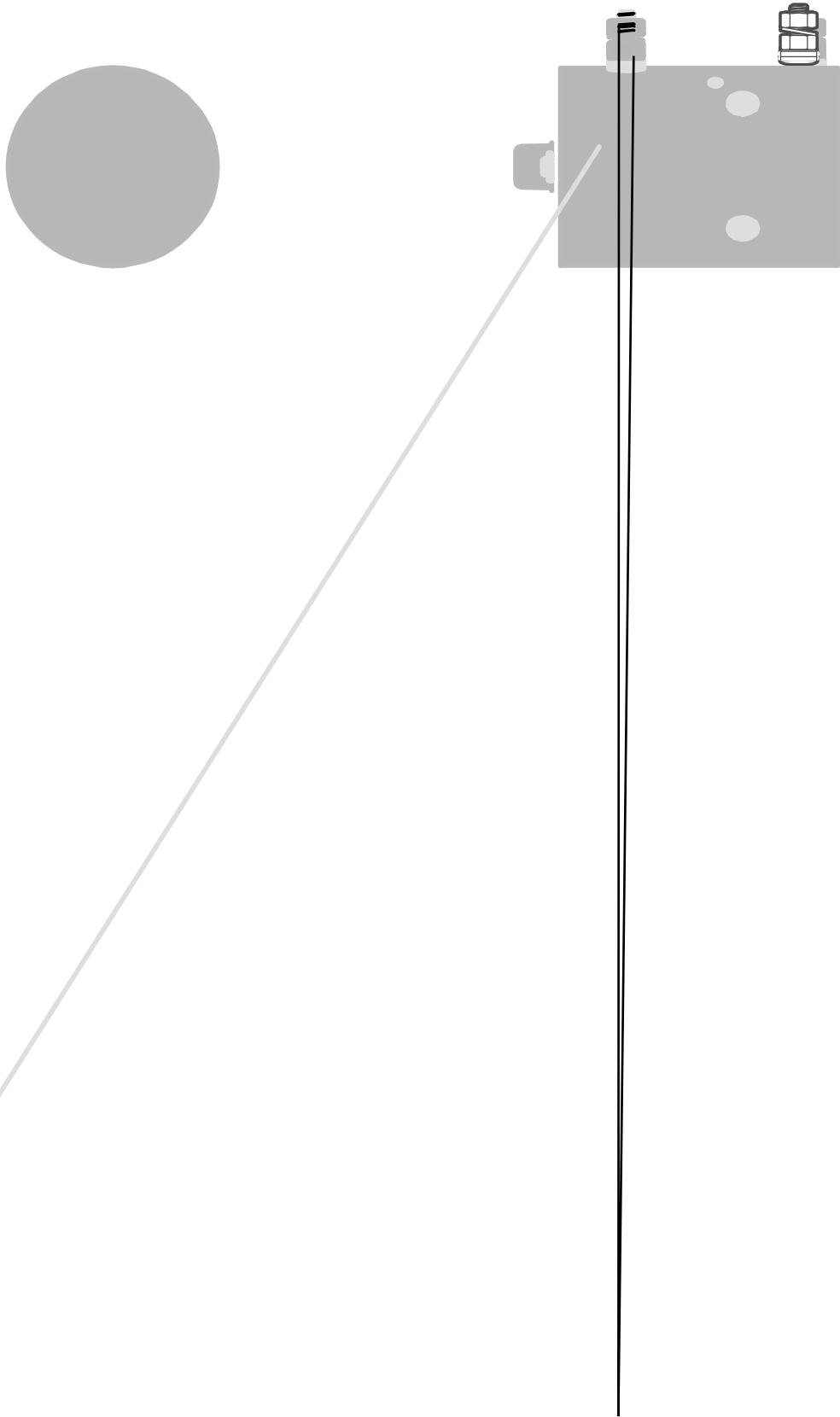

5.6 08196 D.C. Motor Information (Replaces 08100)

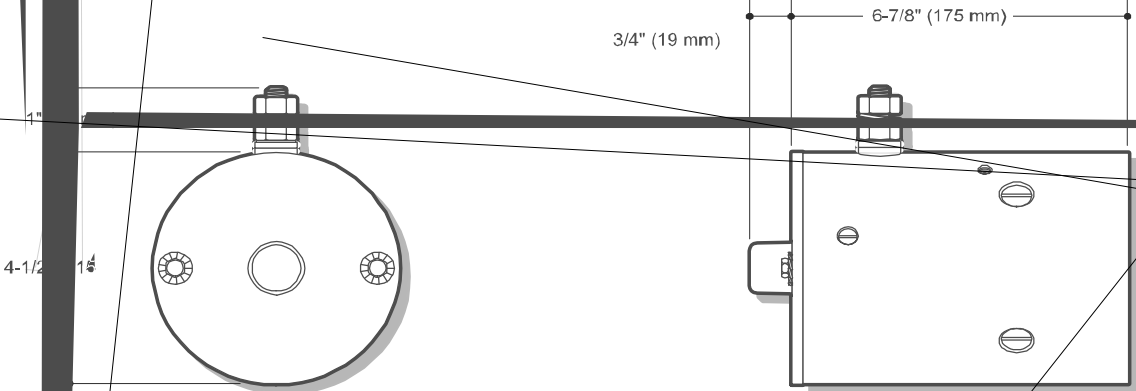

5.7 08050 D.C. Motor Information

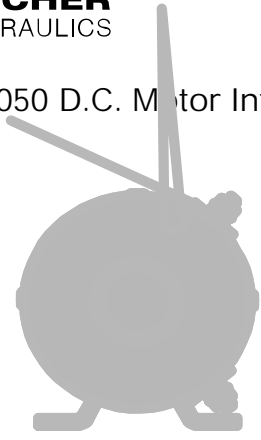

## 5.8 08163 D.C. Motor Information

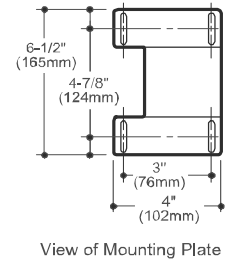
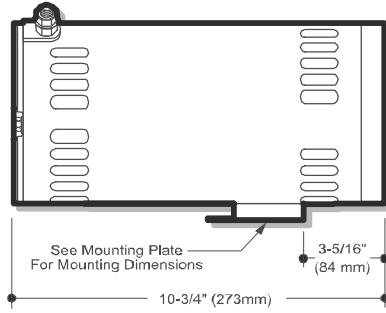
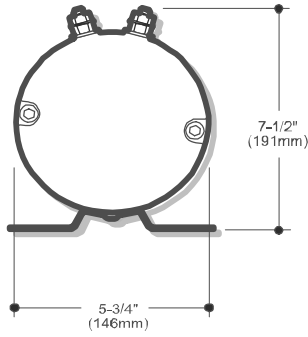

### 12 Volt D.C. Performance graphs

$$\text{Voltage} = 12.3 - \sqrt{\frac{\text{AMP} - 70}{43}} \quad \text{Test Fluid} = \text{Mobil D.T.E. 24} \\ @ 100^{\circ}\text{F (SUS 160)} \\ 34^{\circ}\text{C (CST 34)}$$

### Performance graphs for 08163 Motor

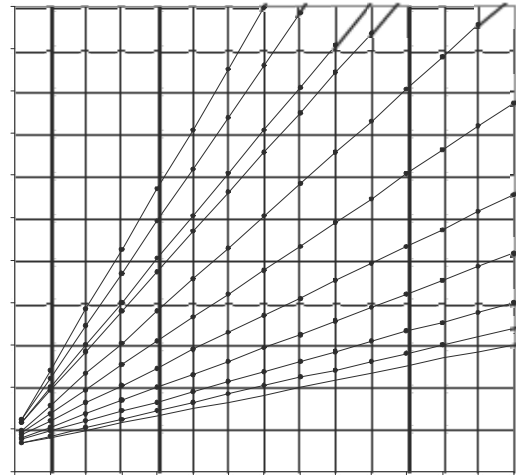



## 5.10 08045 D.C. Motor Information

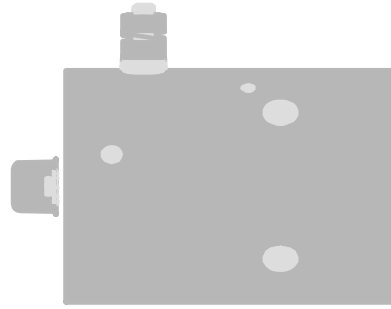
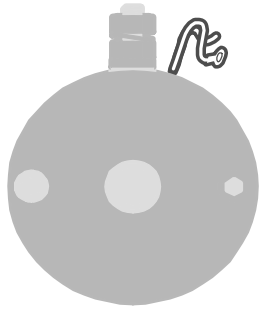

### 5.11 08030 D.C. Motor Information

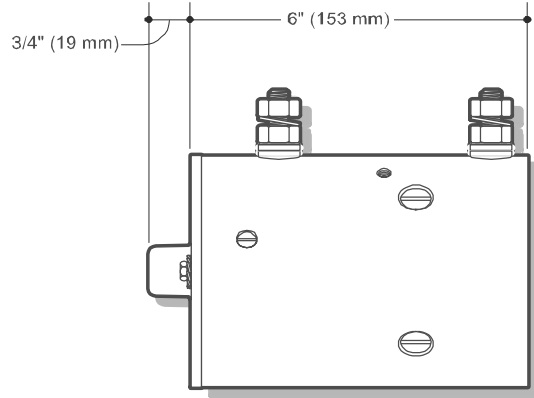
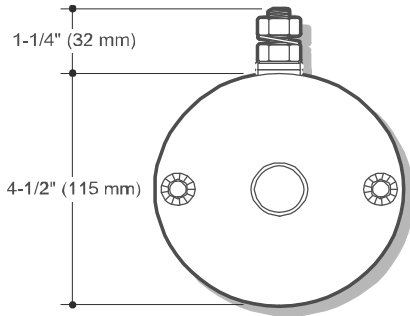

24 Volt D.C. Performance graphs

Voltage =  $12.3 - \sqrt{\frac{AMP - 70}{43}}$  Test Fluid = Mobil D.T.E. 24  
@ 100°F (SUS 160)  
34°C (CST 34)

Performance graphs for 08030 Motor

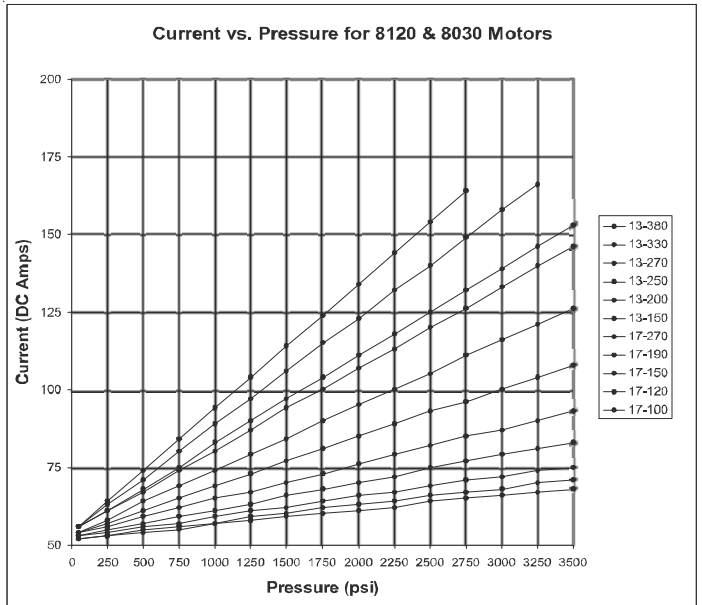
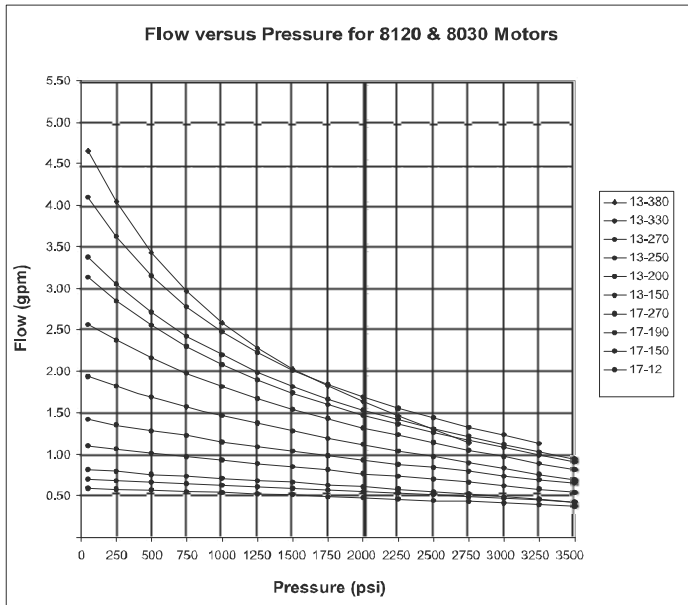

### 5.12 08004 D.C. Motor Information

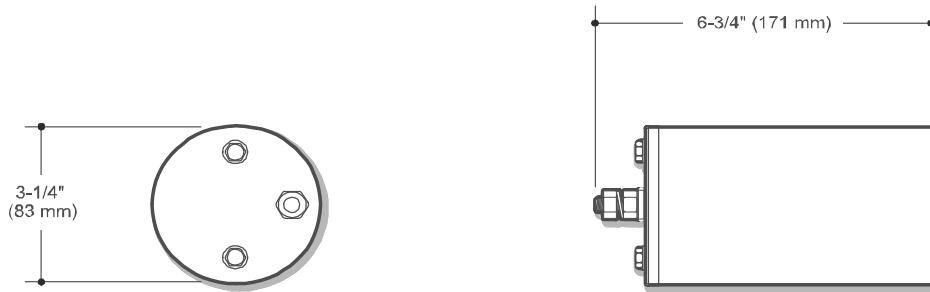

### 12 Volt D.C. Performance graphs

Voltage =  $12.3 - \sqrt{\frac{AMP - 70}{43}}$  Test Fluid = Mobil D.T.E. 24  
@ 100°F (SUS 160)  
34°C (CST 34)

### Performance graphs for 08004 Motor

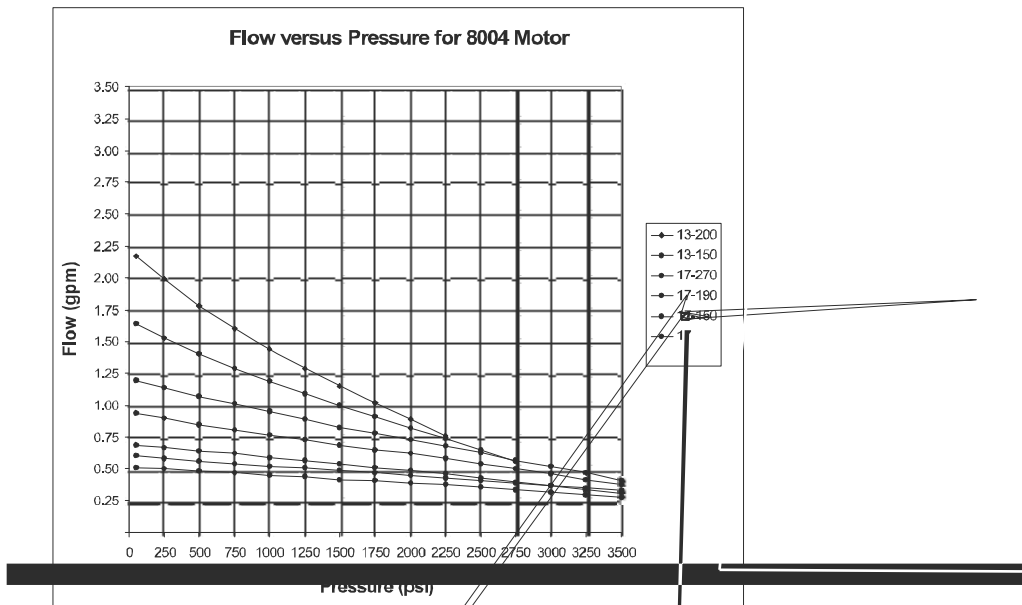

1" (25 mm)

10" (94 mm)

## 5.14 08066 D.C. Motor Information

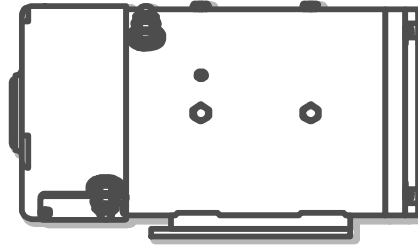
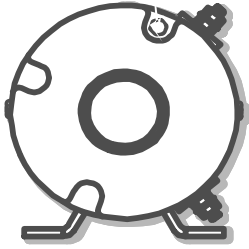

## 5.15 08051 D.C. Motor Information

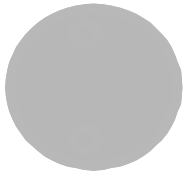

D.T.E. 24  
D°F (SUS 160)  
°C (CST 34)

---

### 5.17 08035 D.C. Motor Information

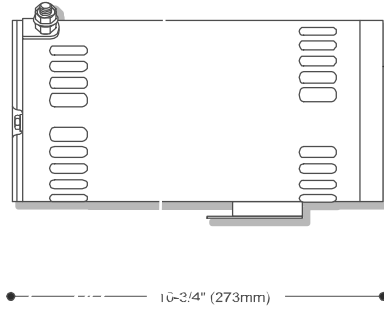
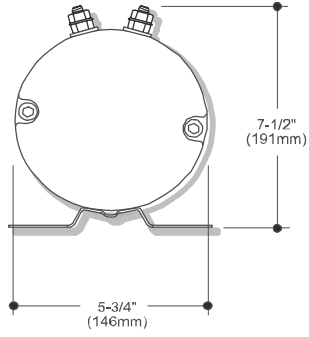

### 5.18 08195 D.C. Motor Information

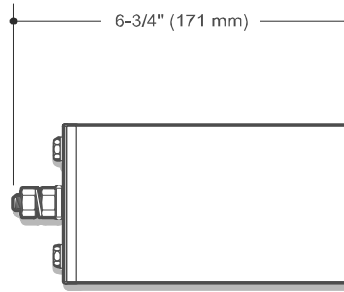
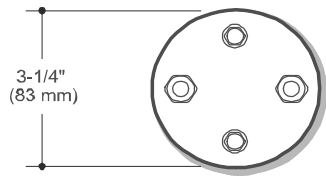

#### 24 Volt D.C. Performance graphs

$$\text{Voltage} = 25.2 - \sqrt{\frac{\text{AMP} - 40}{10}} \quad \text{Test Fluid} = \begin{array}{l} \text{Mobil D.T.E. 24} \\ \text{@ } 100^{\circ}\text{F (SUS 160)} \\ \text{34}^{\circ}\text{C (CST 34)} \end{array}$$

#### Performance graphs for 08195 Motor

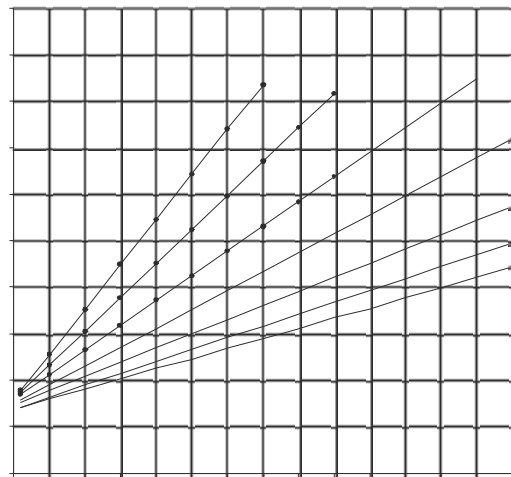



5.20 08055 D.C. Motor Information

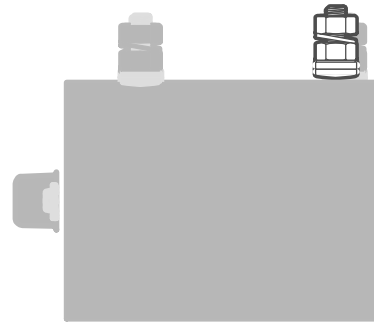
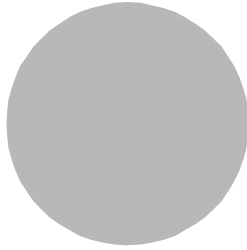

5.21 08040 D.C. Motor Information

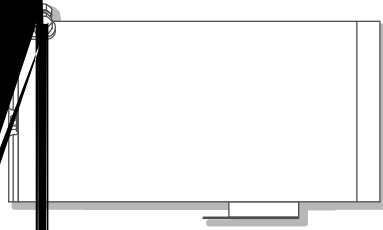
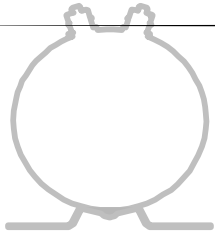

Control Information

3/4

2.5  
2.0  
1.75



00-P-00000

### 5.23 08174 D.C. Motor Information

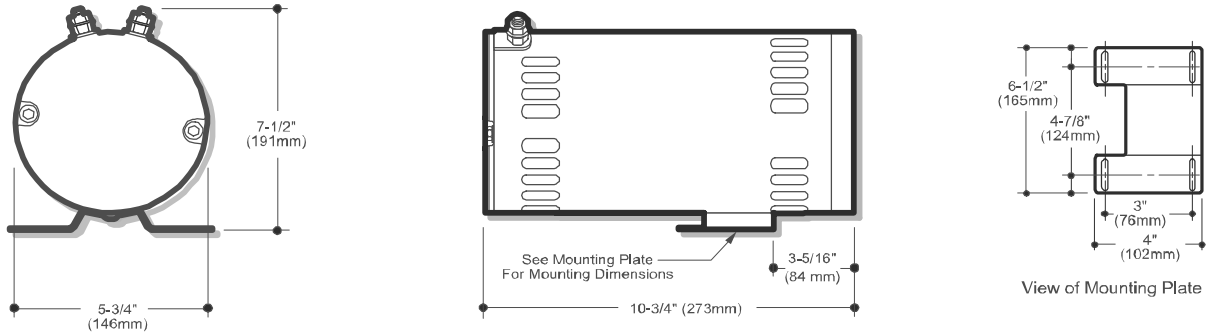

72/80 Volt D.C. Performance graphs

Voltage = 72.4 - .03 x AMPS

Test Fluid = Mobil D.T.E. 24  
@ 100°F (SUS 160)  
34°C (CST 34)

Performance graphs for 08174 Motor

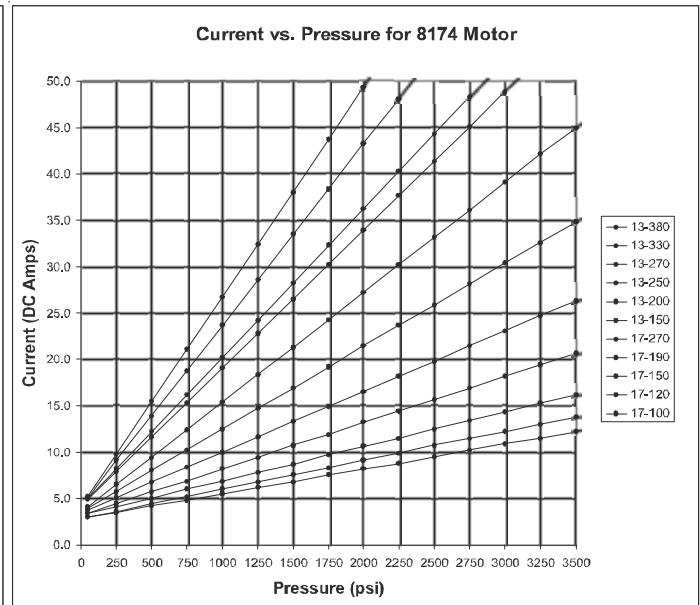
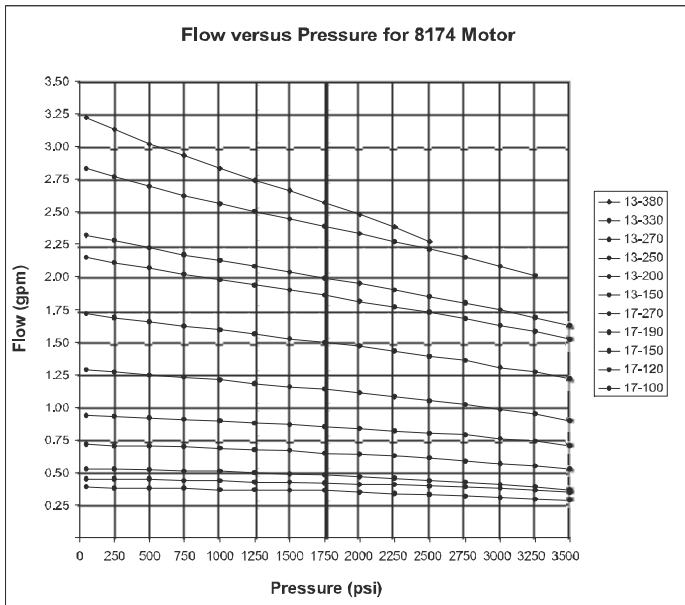

Part Number	Voltage	Insulation Class	Number of Terminal	UL Listed	Description * see Key
08174	72/80	H	2	NO	PM/ID

\* Key to Abbreviations:

PM = Permanent Magnet

SW = Series Wound

ED = Extended Duty

HD = Heavy Duty

ID = Intermittent Duty

CW = Compound Wound

A Thermal Protection Switch is available as an option on most motors and must be used with solenoid motor start switch. For motor thermal performance data, refer to the thermal chart on page 62

## Performance Data

extensive line of D.C. motors that will permit intermittent through extended duty operation to specify the correct motor for your application.

operating temperature and the thermal protection duty cycle, enclosure type and mounting must all be considered.

operating temperature recommendations of the motor manufacturer must be followed.

### Key

A = Amps

M = Single Maximum run time allowed in minutes. Frequently referred to as S2.

% = Maximum allowable run time for a repeating 10\* minute cycle. Frequently referred to as S3. Note. Some motors are rated for a 5 minute cycle and are so noted on the chart.

\* = No data available.

Example: 08111 Motor. At 100 Amps the motor may be operated continuously for 9.5 minutes after which it must be allowed to completely cool to ambient temperature before the cycle can be repeated. Alternatively, at 100 Amps the motor may be operated for repeating cycles of 150 seconds on and 450 seconds off.

Thermal protection switches are also available on many models that will protect motors from overheating. Contact your distributor for more information.

Amps	Run Time (M)	Run Time (%)	Run Time (M)	Run Time (%)
100	9.5	100%	150	100%
150	6.4	75%	100	75%
200	4.8	50%	75	50%
300	3.0	30%	50	30%
450	2.0	20%	30	20%
600	1.5	15%	20	15%
750	1.2	12%	15	12%
1000	0.9	9%	10	9%
1500	0.6	6%	7	6%
2000	0.45	4.5%	5	4.5%

## 6 M Series Reservoirs

### 6.1 M-Series Reservoirs Steel

Part Number	Length in / (mm)	Useable Capacity			
		Horizontal		Vertical	
		Cubic inch (in <sup>3</sup> )	Liter (L)	Cubic inch (in <sup>3</sup> )	Liter (L)
06042	9.00 (229 mm)	190	3.10	168	2.75
06043	10.00 (254 mm)	217	3.56	194	3.20
06044	13.50 (343 mm)	292	4.80	285	4.70
06045	18.00 (458 mm)	394	6.45	405	6.65

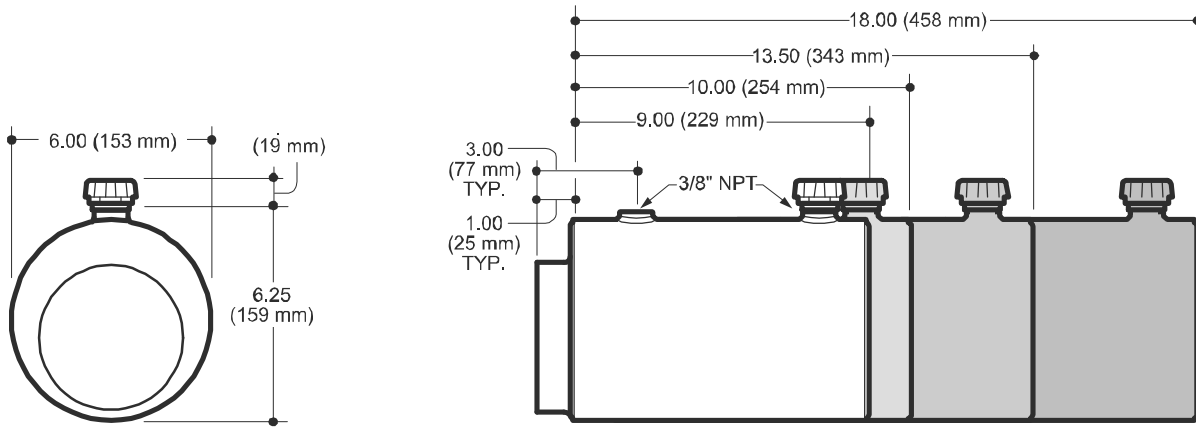

Part Number	Length in / (mm)	Useable Capacity	
		Cubic inch (in <sup>3</sup> )	Liter (L)
06661	8.00 (204 mm)	60	1.00
06663	10.00 (254 mm)	85	1.40
06664	11.00 (280 mm)	98	1.60
06665	12.00 (305 mm)	111	1.80

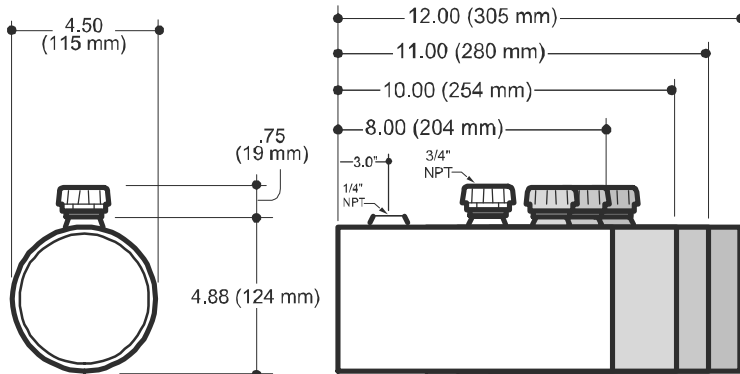

Part Number	Length in / (mm)	Useable Capacity	
		Cubic inch (in <sup>3</sup> )	Liter (L)
06861	7.00 (178 mm)	236	3.86
06862	10.00 (254 mm)	348	5.70
06328	12.00 (305 mm)	406	6.65
06864	15.00 (381 mm)	510	8.36
06883	21.00 (534 mm)	715	11.72

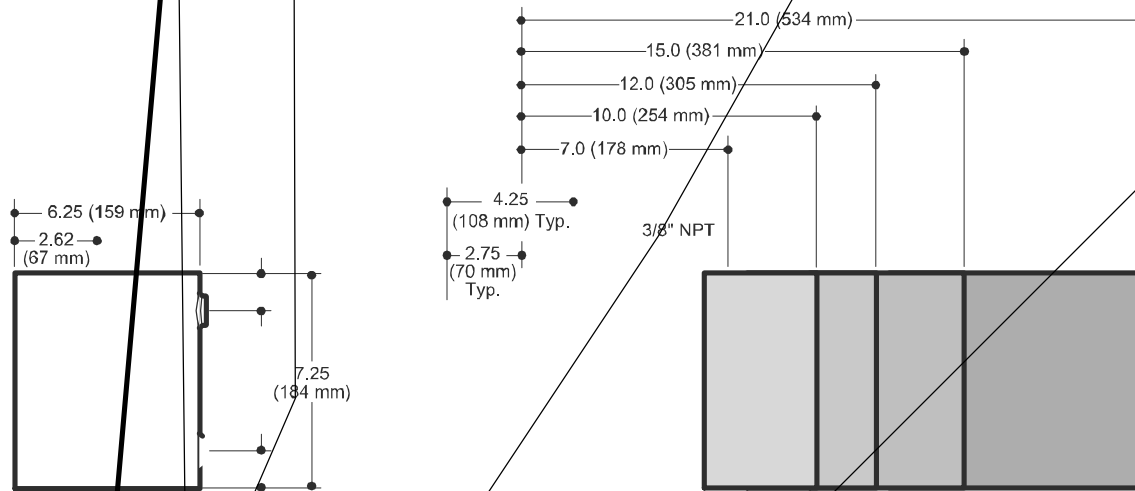

Useable Capacity		
Part Number	Cubic inch (in <sup>3</sup> )	Liter (L)
14249	1155	18.92

This reservoir is not suitable for modular power units.

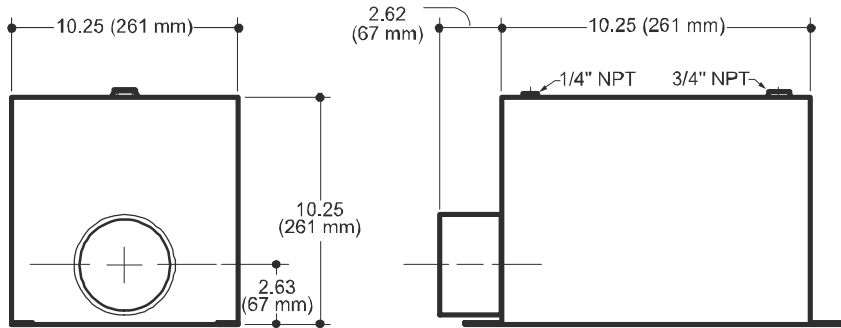

## 6.2 M-Series Reservoirs Poly

Part Number	Horizontal		Length in / (mm)
	Useable Capacity		
	Cubic inch (in <sup>3</sup> )	Liter (L)	
06102	54.92	0.90	8.00 (203.20)
06103	75.67	1.24	10.00 (254.00)
06104	96.41	1.58	12.00 (304.80)
06105	106.79	1.75	13.00 (330.20)

Part Number	Vertical		Length in / (mm)
	Useable Capacity		
	Cubic inch (in <sup>3</sup> )	Liter (L)	
04616	36.61	0.60	8.00 (203.20)
04617	65.91	1.08	10.00 (254.00)
04618	95.20	1.56	12.00 (304.80)
04619	109.84	1.80	13.00 (330.20)

Useable Capacity may be increased 7.5% with the addition of a suction shroud assembly 13082. When using an I pump, up to 3% reduction in useable volume should be expected.

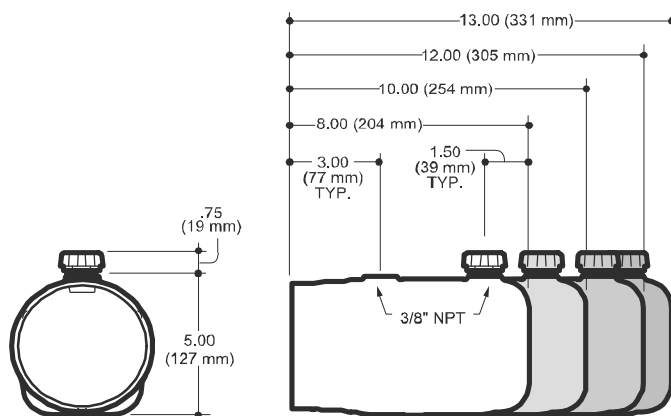

### 6.3 M-Series Reservoirs Poly 5.5~x6.5~ Top

Part Number	Horizontal		Length in / (mm)
	Useable Capacity		
	Cubic inch (in <sup>3</sup> )	Liter (L)	
14157	143.40	2.35	10.00 (254.00)
14158	220.00	3.61	13.50 (342.90)
14159	347.23	5.69	19.00 (482.60)
04845	143.40	2.35	10.00 (254.00)
04846	220.00	3.61	13.50 (342.90)
04687	326.48	5.35	19.00 (482.60)

Useable Capacity may be increased 8% with the addition of a suction shroud assembly 13082 When using an I pump, up to 3% reduction in useable volume should be expected.

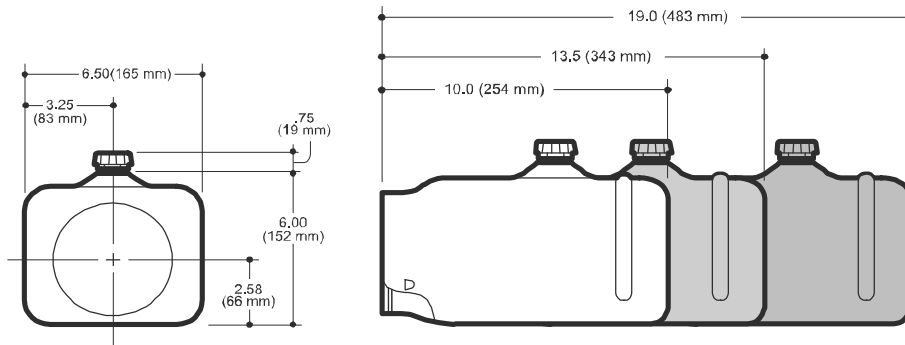

These reservoirs are not suitable for some modular power units. Consult factory for optional reservoirs for your application.

## 6.4 M-Series Reservoirs Poly 6~ Centered

Part Number	Horizontal		Length in / (mm)
	Useable Capacity		
	Cubic inch (in <sup>3</sup> )	Liter (L)	
14128	118.37	1.94	9.00 (228.60)
14121	136.19	2.23	10.00 (254.00)
14122	154.01	2.52	11.00 (279.40)
14123	189.65	3.11	13.00 (330.20)
14124	234.20	3.84	15.50 (393.70)
14125	296.57	4.86	19.00 (482.60)
14126	350.03	5.74	22.00 (558.80)
14127	385.68	6.32	24.00 (609.60)

Part Number	Vertical		Length in / (mm)
	Useable Capacity		
	Cubic inch (in <sup>3</sup> )	Liter (L)	
14004	197.04	3.23	13.00 (330.20)
14005	268.68	4.40	15.50 (393.70)

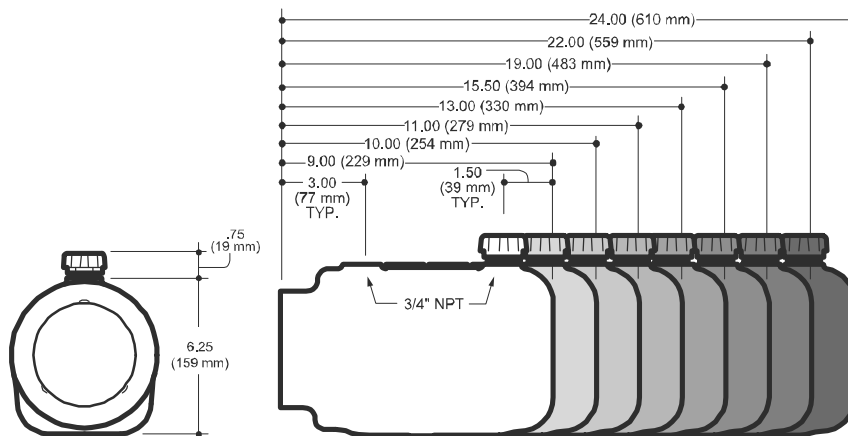

Useable Capacity may be increased 6% with the addition of a suction shroud assembly 13082 When using an I pump, up to 3% reduction in useable volume should be expected.

These reservoirs are not suitable for some modular power units. Consult factory for optional reservoirs for your application.

## 6.5 M-Series Reservoirs Poly 6~ Offset

Part Number	Horizontal		Length in / (mm)
	Useable Capacity		
	Cubic inch (in <sup>3</sup> )	Liter (L)	
14009	123.57	2.03	9.00 (228.60)
14010	143.40	2.35	10.00 (254.00)
14011	163.23	2.68	11.00 (279.40)
14012	202.89	3.33	13.00 (330.20)
14013	252.47	4.14	15.50 (393.70)
14014	321.87	5.28	19.00 (482.60)
14015	381.36	6.25	22.00 (558.80)
14016	421.02	6.90	24.00 (609.60)

Part Number	Vertical		Length in / (mm)
	Useable Capacity		
	Cubic inch (in <sup>3</sup> )	Liter (L)	
14004	88.49	1.45	9.00 (228.60)
14005	112.90	1.85	10.00 (254.00)
14005	137.31	2.25	11.00 (279.40)
14005	186.13	3.05	13.00 (330.20)
14005	247.15	4.05	15.50 (393.70)
14005	332.59	5.45	19.00 (482.60)
14005	405.82	6.65	22.00 (558.80)
14005	454.64	7.45	24.00 (609.60)

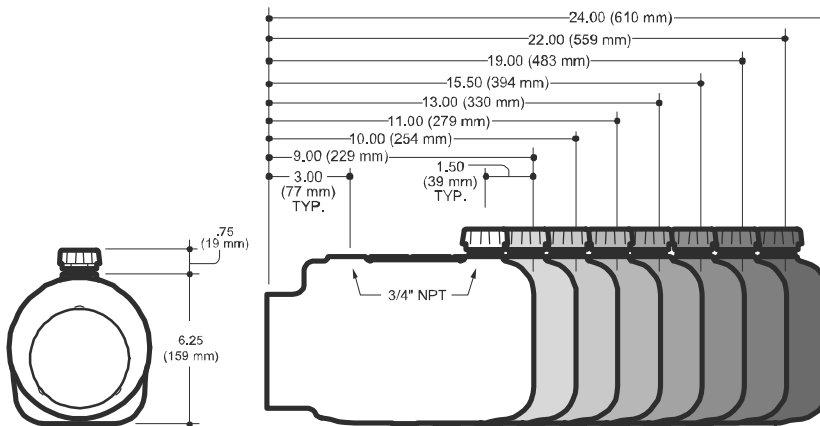

Useable Capacity may be increased 6% with the addition of a suction shroud assembly 13082 When using an I pump, up to 3% reduction in useable volume should be expected.

These reservoirs are not suitable for some modular power units. Consult factory for optional reservoirs for your application.

## 6.6 M-Series Reservoirs Poly 6.75~x6.75~

Part Number	Horizontal		Length in / (mm)
	Useable Capacity		
	Cubic inch (in <sup>3</sup> )	Liter (L)	
14164	157.14	2.58	7.50 (190.50)
14165	203.21	3.33	9.00 (228.60)
14166	264.64	4.34	11.00 (279.40)
14167	326.07	5.34	13.00 (330.20)
14168	387.50	6.35	15.00 (381.00)
14169	541.08	8.87	20.00 (508.00)
14170	725.37	11.89	26.00 (660.40)

Part Number	Vertical		Length in / (mm)
	Useable Capacity		
	Cubic inch (in <sup>3</sup> )	Liter (L)	
14183	85.43	1.40	7.50 (190.50)
14184	149.51	2.45	9.00 (228.60)
14185	234.94	3.85	11.00 (279.40)
14186	320.37	5.25	13.00 (330.20)
14187	404.81	6.63	15.00 (381.00)
14188	619.39	10.15	20.00 (508.00)
14189	875.69	14.35	26.00 (660.40)

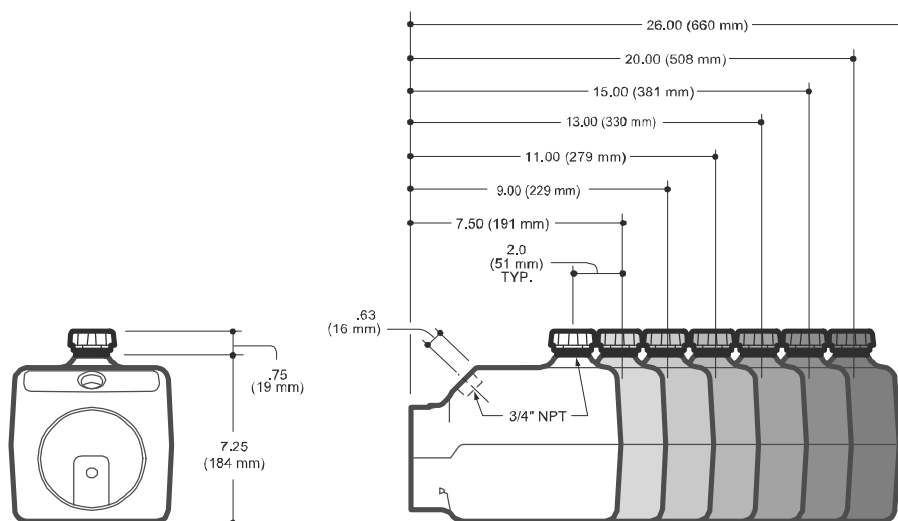

Useable Capacity may be increased 5% with the addition of a suction shroud assembly 13082. When using an I pump, up to 3% reduction in useable volume should be expected.

These reservoirs are not suitable for some modular power units. Consult factory for optional reservoirs for your application.

## 6.7 M-Series Reservoirs Poly 9~x10~

Horizontal			Length in / (mm)
Part Number	Useable Capacity		
	Cubic inch (in <sup>3</sup> )	Liter (L)	
14223	909.27	14.90	16.00 (406.40)
14224	1070.00	17.54	18.00 (457.20)
14225	1232.09	20.19	20.00 (508.00)

Vertical			Length in / (mm)
Part Number	Useable Capacity		
	Cubic inch (in <sup>3</sup> )	Liter (L)	
14226	793.33	13.00	16.00 (406.40)
14227	979.46	16.05	18.00 (457.20)
14228	1165.58	19.10	20.00 (508.00)

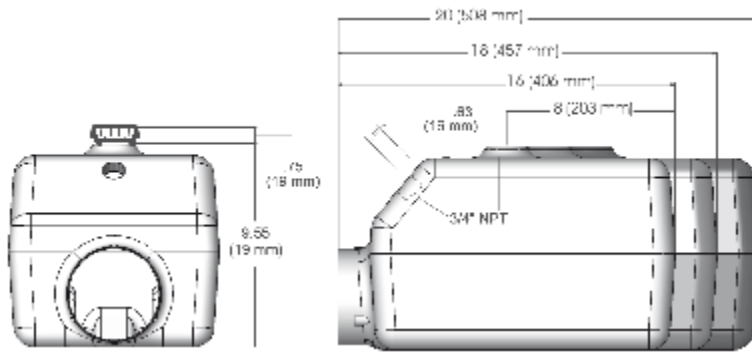

Useable Capacity may be increased 5% with the addition of a suction shroud assembly 13082 When using an I pump, up to 3% reduction in useable volume should be expected.

These reservoirs are not suitable for some modular power units. Consult factory for optional reservoirs for your application.

## 6.8 Reservoirs for Mini Units Poly 3.5"x3.5" MINI

Part Number	Horizontal		Vertical		Length in / (mm)
	Useable Capacity				
	Cubic inch (in <sup>3</sup> )	Liter (L)	Cubic inch (in <sup>3</sup> )	Liter (L)	
06230	30.51	0.50	24.50	0.40	6.46 (164.08)
06231	62.04	1.02	69.22	1.13	11.08 (281.43)
06233*	125.10	2.05	158.67	2.60	20.32 (516.13)

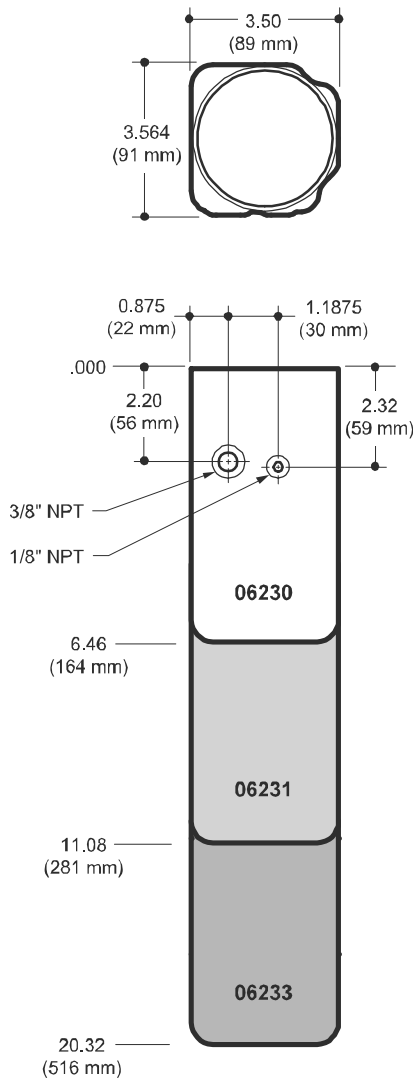



\* Reservoir should not be used in a horizontal application without first consulting engineering (Special supports may be required).

**BUCHER**  
HY

## 6.10 Valves for DC Systems

NPFA DO3 Directional and Auxiliary Control Valves.

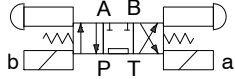
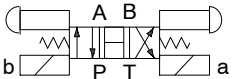
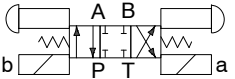
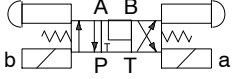
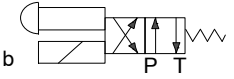
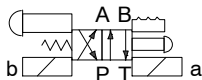
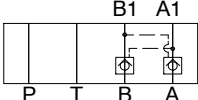
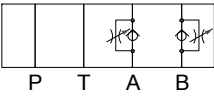
Solenoid directional and auxiliary controls are typically added to the M-3515 and M-3528. Please refer to the Monarch Directional Control Valve brochure for additional information and selection.

Part Number	Schematic	Description
12 VDC - 00962 24 VDC - 00965		4-Way/3-Position. Solenoid Operated. Tandem Center.
12 VDC - 00963 24 VDC - 00966		4-Way/3-Position. Solenoid Operated. Open Center.
12 VDC - 00961 24 VDC - 00964		4-Way/3-Position. Solenoid Operated. Closed Center.
12 VDC - 01040 24 VDC - 01039		4-Way/3-Position, P Blocked. A and B to T. "Motor Spool".
12 VDC - 00460 24 VDC - 00461		4-Way/2-Position. P to A. Spring Offset.
12 VDC - 00460 24 VDC - 00461		4-Way/2-Position. P to A. Spring Offset.
00468		Dual Pilot Operated Check. A and B Port.
00469		Flow Control. Dual Meter Out. A and B Port.
00443		Cross Port Relief. A and B Ports. Adjustable.
00474		

Cartridge Valves

Solenoid operated cartridge valves are used in many applications. Models.

Part Number	Description
12 VDC - 00707 24 VDC - 07158	2-Way/2-Position Normally Closed. Modified Cavity #8. Grounded Coil.
07144	2-Way/2-Position Normally Closed. Modified Cavity #8. Manual Operation. Pull to Open. Spring Closed.
12 VDC - 00501 24 VDC - 00502	2-Way/2-Position Normally Open. Modified Cavity #8. Grounded Coil.

Consult Factory about many additional valve options.

Manual Valves

Manually Operated Directional Control Valves are used in many applications. Models M-300 and M-300 Special Units.

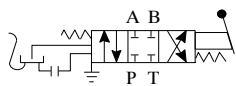
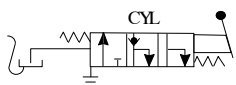
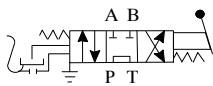
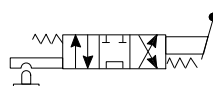
Part Number	Description
M-3310 Condenser Type - 01020	 4-Way/3-Position. Closed Center. Direct Mounting.
M-500 Type - 00853	 3-Way/3-Position. Cylinder Port Checked. Direct Mounting.
M-3310 Condenser Type - 00893 M-500 Type - 00856 (Non Condenser Type)	 4-Way/3-Position. Tandem Center. Direct Mounting.
M-3310 Cam Start SW - 07120	

## 6.11 Motor Start Switches for D.C. Power Systems

### Wiring Diagrams

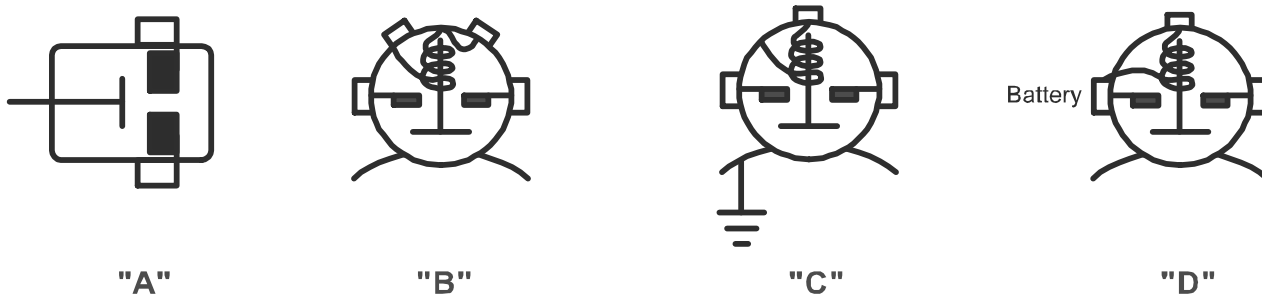

Part Number	Voltage	Wiring diagram	Coil Duty	Description
03336	12	D	Int.	Insulated Ground
17757	12	C	Int.	
17744	12	B	Int.	
17764	24	B	Int.	
03322	12/24	A	N.A.	Manual Start Only - M-3301, M-3313
04343	12/24	A	N.A.	Round Valve. Cam Start M-3310 Only
01349	N.A.	N.A.	N.A.	Bus Bar
13155	N.A.	N.A.	N.A.	Bus Bar for use with 17764, 17744 & 17757 Solenoids
01361	N.A.	N.A.	N.A.	Battery Cable, 5" Long
01628	N.A.	N.A.	N.A.	Battery Cable, 6" Long

Switches are available with curved mounting for direct attachment to power unit or with flat base for remote mounting. Other Motor Start Switches are also available. Contact Factory.

Key To Abbreviations:     H.D. = Heavy Duty  
                                   Int. = Intermittent Duty

## 6.12 Control Boxes

Figure1

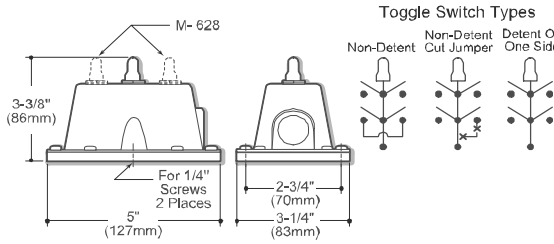

Figure2

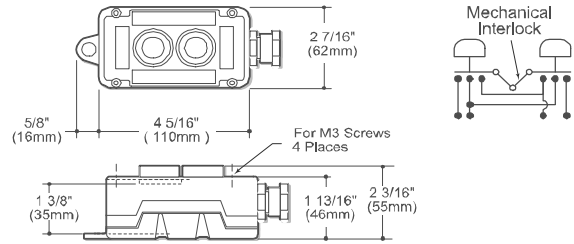

Figure3

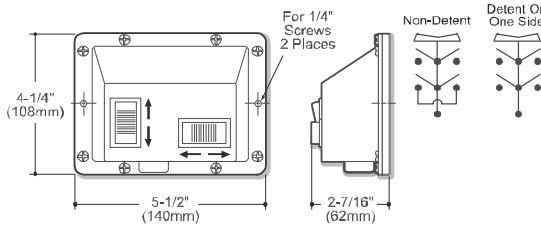

Figure4

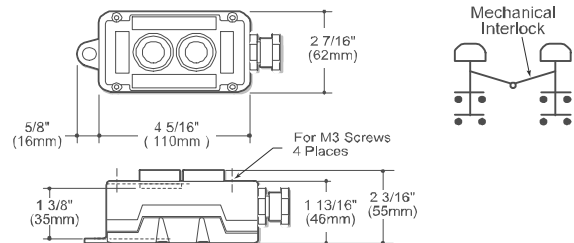





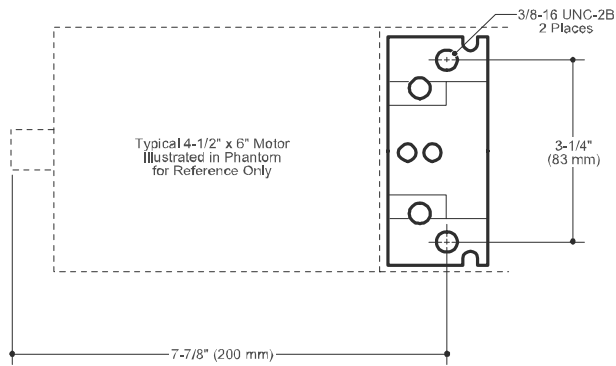

Figure	Switch Symbol	Models used on	Part Number
1*		M-3303, M-3319, M-3314, M-3519, M-3541	03409
1*		M-642, M-3551, M-3515, M-3554	03487
1*		M-3528 M-3303, M-3319, M-3314, M-3519, M-719	03451
1*		M-642, M-3551, M-3515, M-3530, M-3547, M-3554	07995
1*		M-680'S	03197 (Detented) 03201 (Non-Detendet)
1*		M-3303, M-3315, M-3314	07993

NOTE: The above Control Stations may be used with other Power Units. Consult Factory.

## 6.13 Mounting Brackets



04560

May Be Used on Most M Series Units with 4.5" Ø (114mm Ø) Base, M 10 x 1.5 Thread also Available. Consult Factory.

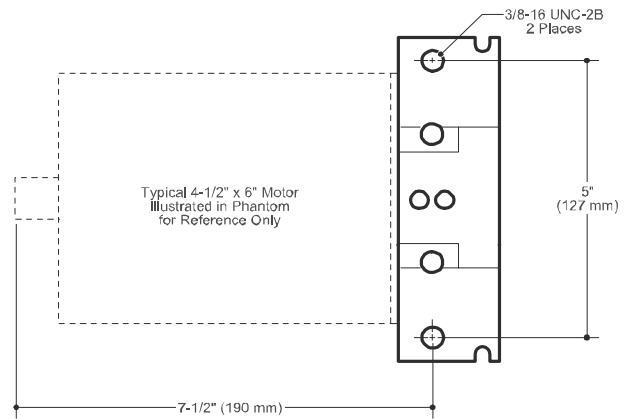

04559

May Be Used on Most M Series Units with 4.5" Ø (114mm Ø) Base, M 10 x 1.5 Thread also Available. Consult Factory.

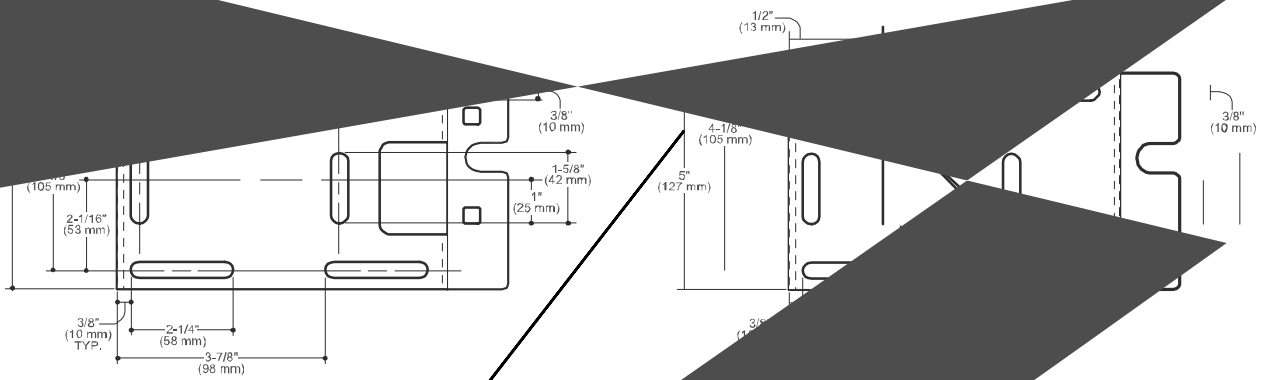

02238

May Be Used With Motors: 08055, 08171, 18442, 80000

## 6.14 Popular Accessories For DC Power Systems

Part Number	Description
01436	Sight Level/Temperature Gauge. For Use on Large Reservoirs Only.
01516	Reservoir Breather, Flush Mount, .375" NPT. Cross Scored.
03171	Reservoir Breather, .375" NPT.
01143	Reservoir Breather, .750" NPT.
01670	Sight Glass. 3/4" NPT.
03219	Pressure Gauge. Liquid Filled. 1/4" NPT. 0-500 PSI.
01434	Pressure Gauge. Liquid Filled. 1/4" NPT. 0-3000 PSI.
01790	Pressure Gauge. Liquid Filled. 1/4" NPT. 0-5000 PSI.
00570	Gauge Shutoff. 1/4" NPT.
00904	Flow Control, Adjustable. Non Pressure Compensated. 1/4" NPT. F x F For Flows to 3.0 GPM (11.4 LPM).
01720-X.XX	Flow Control, Pressure Compensated. Fixed. 1/4" NPT F x F. Other Types Available. Specify Flow Required.
01875	Filter, Return Line. 15 GPM. 10 Micron Nominal.
04369	Filter, Return Line. 5 GPM. 10 Micron Nominal.
01425	Filter/Breather, Chrome Plated. Basket Strainer.
04202	M-310 Cam Start Switch Conversion Kit.
07157	Relief Valve, Cartridge. 1500-3000 PSI. Other Pressure Ranges Also Available.
01506	Terminal Cover, Rubber. #4 Cable.
03981	Hand Pump, Standard.
03987	Hand Pump, Mini Direct, Right Hand. High Pressure - Low Displacement.
03943	Hand Pump, Mini Direct, Left Hand. High Pressure - Low Displacement.
07435	Hand Pump, High Pressure - Heavy Duty.
03695	Valve Cover Cap Kit, M-693.

Other Available Options and Accessories Include:

- Float Switches
- Special Manifold Circuits
- Pressure Switches
- Multi-Function Valve Controls - Monoblock and Sectional
- Special Cartridge, Industrial and Manual Valve Configurations.

NOTE: Accessories Will Not Fit Every Model. Please Contact the Factory For Assistance.

## 6.15 Monarch Hand Pumps

Standard - Standard Displacement (0.50 In<sup>3</sup>/Stroke) High Pressure - Low Displacement (0.25 In<sup>3</sup>/Stroke) High Pressure/  
Heavy Duty - Standard Displacement (0.50 In<sup>3</sup>/Stroke)

Note: It is recommended that pins and piston be periodically lubricated to prolong hand pump life.

## 6.16 Standard Hand Pumps

### Description

- 0.50 In<sup>3</sup>/Stroke (8.20 Cm<sup>3</sup>/Stroke)
- Single Acting
- 2000 PSI (138 Bar)
- Outlet Port: 1/4" NPTF
- Ideal For Emergency Back-Up Application in Case of Primary Pump Failure
- Horizontal or Vertical Mounting
- Designed for Mounting Directly to Monarch Power Units
- Handle May Positioned in any Direction
- Release Valve (Use Handle for Actuating)
- Supplied with Painted Steel "Comfort Grip" Handle
- All Exposed Materials are Aluminum or Plated Steel for Corrosion Resistance

### Popular Options

- Remote Mounting
- Ports. Other Styles Available
- Relief Valve
- Integral Reservoir

### Schematic

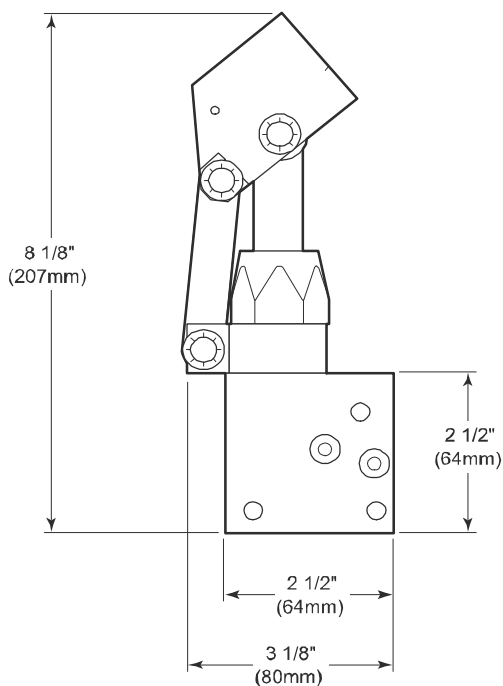
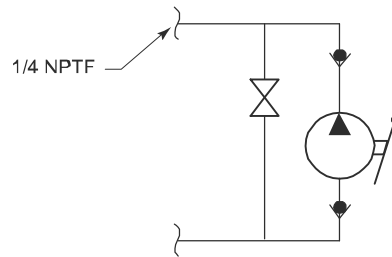

**SIDE VIEW**

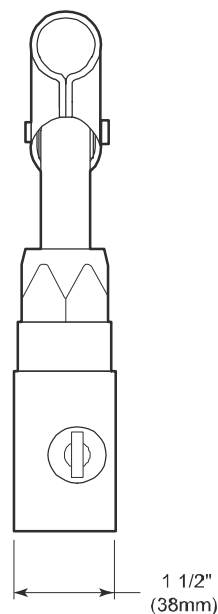

**END VIEW**

BUCHER

INT

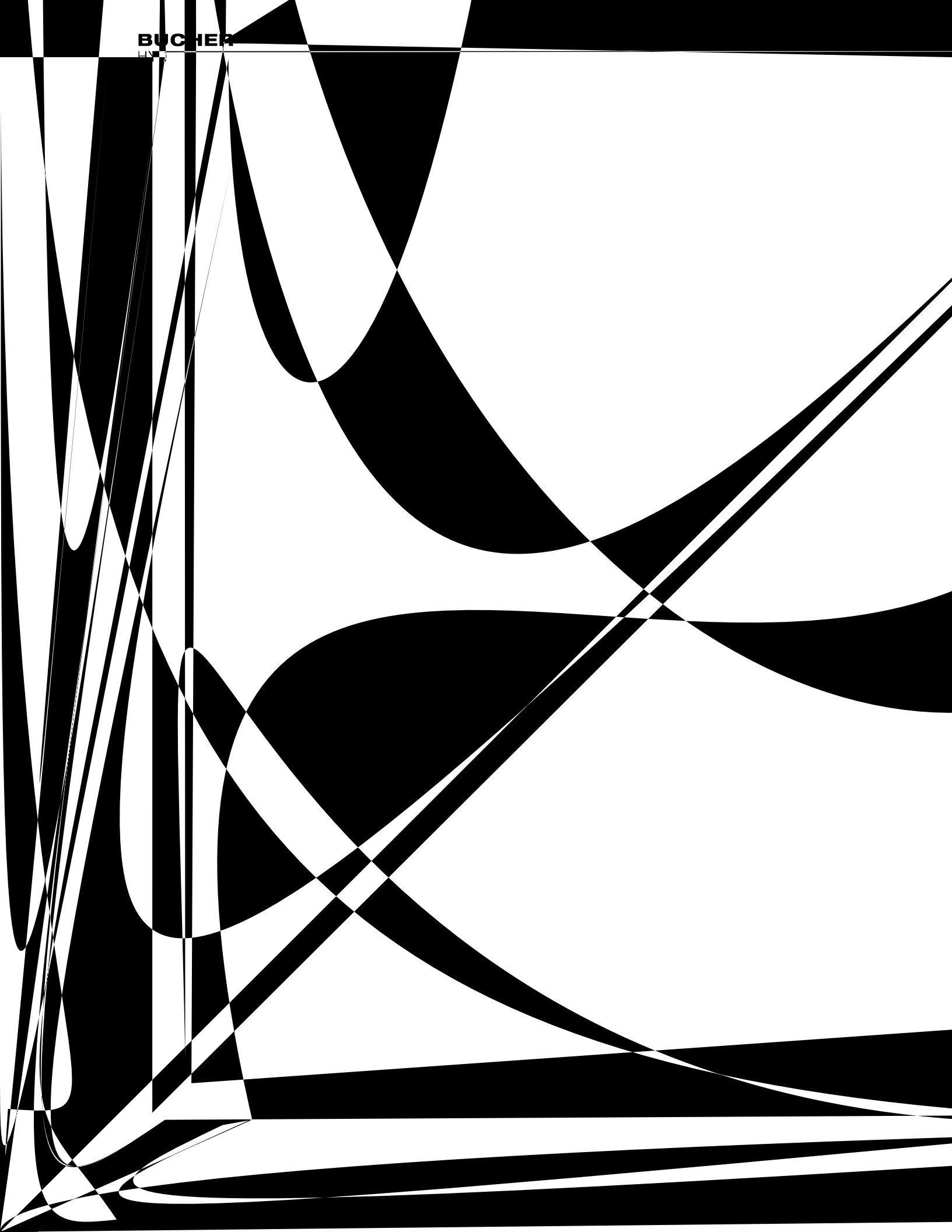

## 6.18 High Pressure - Heavy Duty Hand Pump

### Description

- 0.50 In<sup>3</sup>/Stroke (8.20 Cm<sup>3</sup>/Stroke)
- Single Acting
- 4000 PSI (275 Bar)
- Outlet Port: 1/4" NPTF
- Heavy Duty Plated Steel Tension Link and Extruded Aluminum Top and Bottom Brackets
- Ideal For Emergency Back-Up Application in Case of Primary Pump Failure
- Horizontal or Vertical Mounting
- Designed for Mounting Directly to Monarch Power Units
- Handle May Positioned in any Direction
- Release Valve (Use Handle for Actuating)
- Supplied with Painted Steel "Comfort Grip" Handle
- All Exposed Materials are Aluminum or Plated Steel for Corrosion Resistance

### Popular Options

- Remote Mounting
- 1/4" NPTF Ports. Other Styles Available
- Relief Valve

### Schematic

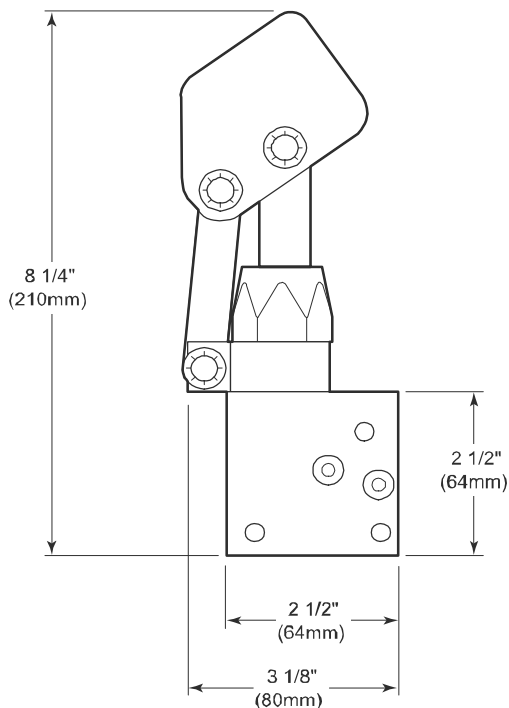
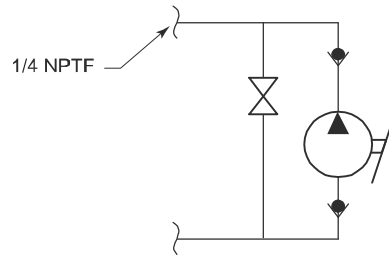

**SIDE VIEW**

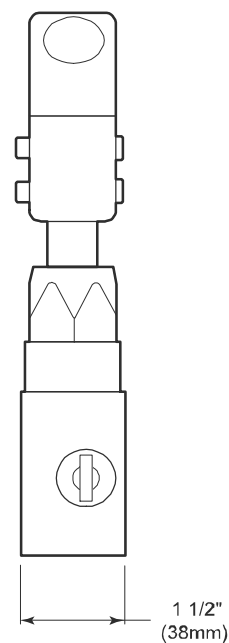

**END VIEW**

## 6.19 Heavy Duty Remote Hand Pump

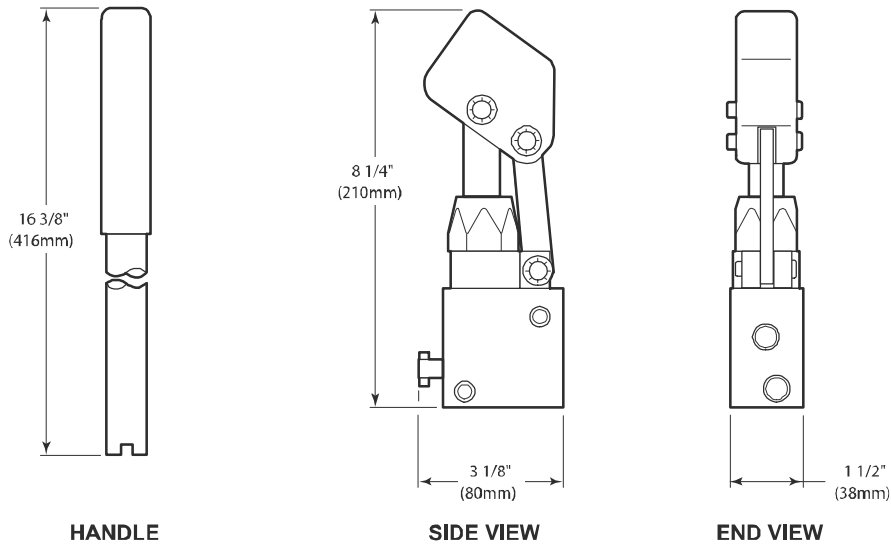

## 6.20 Model H-100 Series Hand Pumps With Reservoirs

Hand Pump with Relief Valve and Reservoir

- 12139 Standard Duty Hand Pump with Relief Valve
- 12140 Heavy Duty Hand Pump with Relief Valve

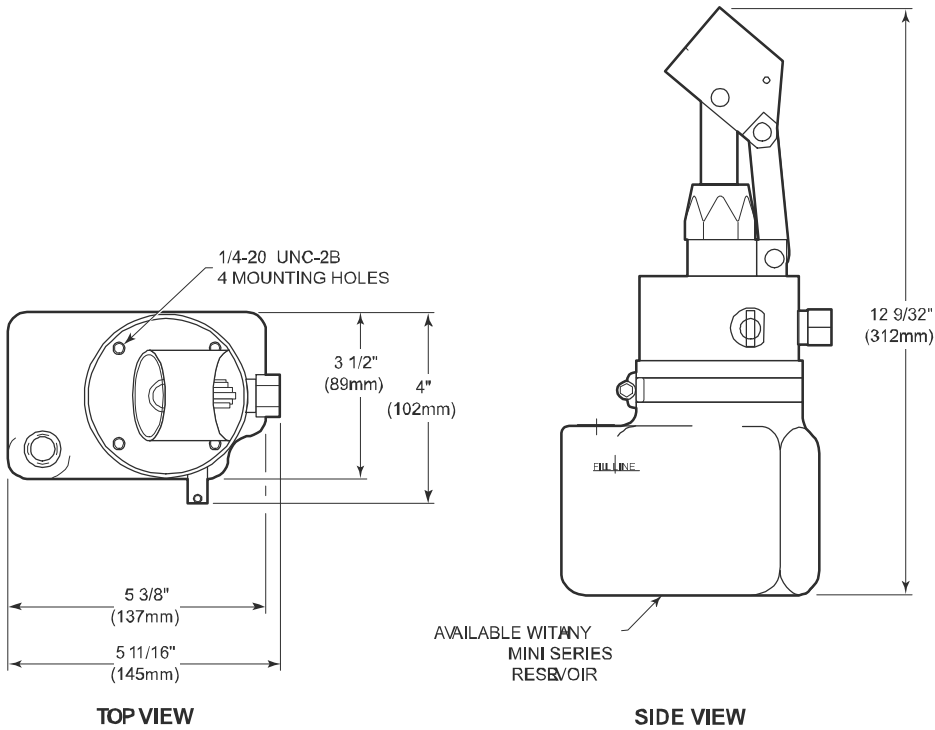

## 6.21 Battery Cables

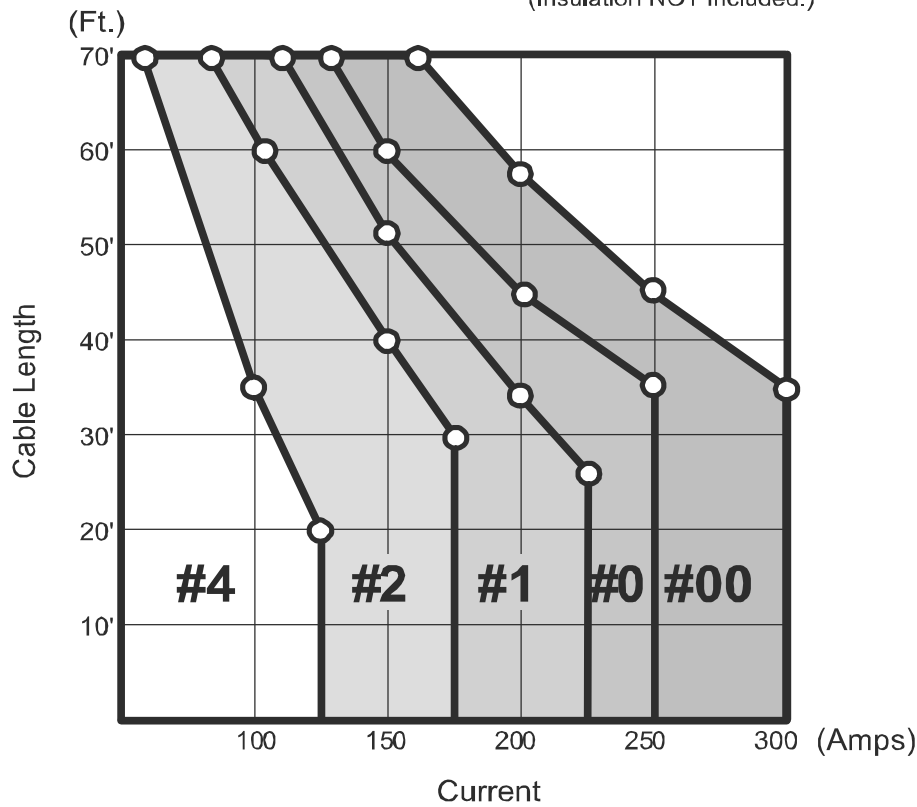
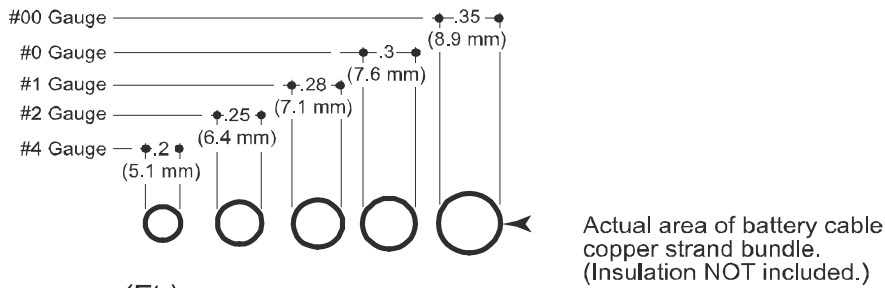

- For best results, Monarch would recommend that you increase 1 or 2 cable sizes above the minimum shown above. Select cable size so that your cable length and maximum amp draw falls below and to the left of curve.
- Curve describes a 1 volt loss in the battery cable itself.
- Total length of battery cable(s) including all ground cables.

Example: With maximum current draw of 200 amps and total cable length of 28 ft (7.82m), Select #1 gauge (.28 in/7.1mm) or larger.

## 6.22 Limited 1 Year Warranty

Bucher Hydraulics, Inc. ("Bucher") makes the following warranty to any party who purchases this Bucher Hydraulics, Inc. product directly from Bucher Hydraulics, Inc. with the intention of either reselling this Bucher Hydraulics, Inc. product or incorporating it into or attaching it to some other product ("the purchaser").

Bucher Hydraulics, Inc. warrants to the purchaser that this product is free from any substantial defects in materials and workmanship. If this product proves to be defective in materials or workmanship during the period of this warranty, Bucher Hydraulics, Inc. will repair or replace, at its option, the defective product free of charge (except for transportation charges as provided below). The period of this warranty is the (1) year period beginning from the date of shipment of this Bucher Hydraulics, Inc. product by Bucher Hydraulics, Inc. to the purchaser.

To obtain warranty service, the purchaser must call Bucher Hydraulics, Inc. to have a return goods authorization number assigned to them. The purchaser should then send the product claimed to be defective within the warranty period, transportation prepaid, to: Bucher Hydraulics, Inc., 1363 Michigan Street N.E., Grand Rapids, MI. 49503, USA. Bucher Hydraulics, Inc. will then repair or replace, at its option, items which it finds to have been defective. Bucher Hydraulics, Inc. will return such repaired or replacement items to the sender free of charge. Items claimed by the purchaser, but not found by Bucher Hydraulics, Inc., to be defective will be returned to the purchaser by a reasonably expeditious means at the purchaser's expense. This expense may include labor charges incurred from inspecting the unit.

This warranty does not extend to any failure of this Bucher Hydraulics, Inc. product to perform as warranted hereinabove which is caused by misuse, abuse or material alteration of this product, or any negligence in connection with the installation, service, or use of this product by any person other than Bucher Hydraulics, Inc.

Bucher Hydraulics, Inc. hereby expressly disclaims any liability for consequential damages to property other than this Bucher Hydraulics, Inc. product to perform as warranted hereinabove.

Note: Supersedes all former warranties written or implied.